

Owner's Manual Power Take-Offs

Effective: February 2010
Supersedes: HY25-1380-M1/US December 2009

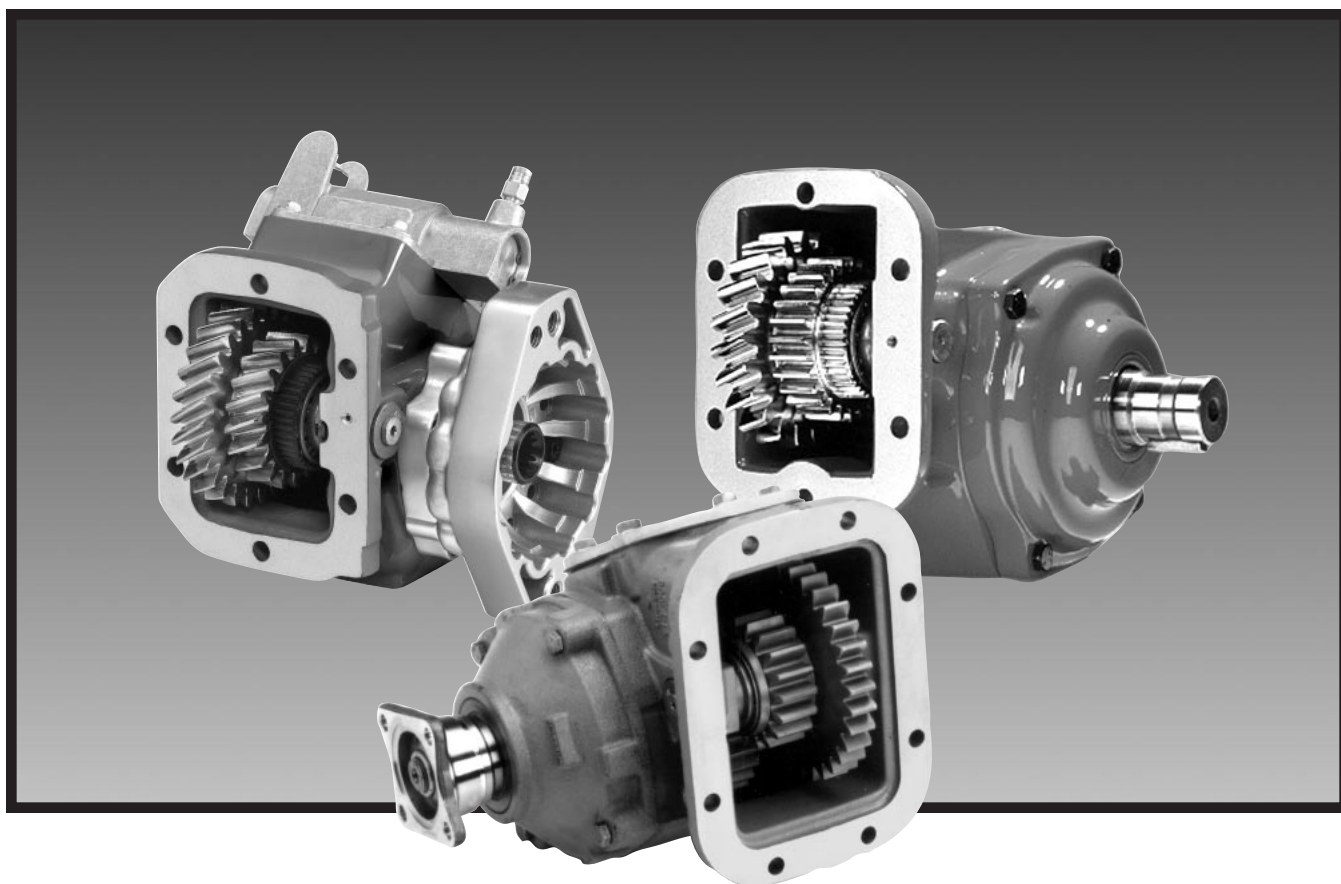

267 Series
269 Series

277 Series
278 Series

859 Series
867 Series



WARNING — User Responsibility

FAILURE OR IMPROPER SELECTION OR IMPROPER USE OF THE PRODUCTS DESCRIBED HEREIN OR RELATED ITEMS CAN CAUSE DEATH, PERSONAL INJURY AND PROPERTY DAMAGE.

This document and other information from Parker-Hannifin Corporation, its subsidiaries and authorized distributors provide product or system options for further investigation by users having technical expertise.

The user, through its own analysis and testing, is solely responsible for making the final selection of the system and components and assuring that all performance, endurance, maintenance, safety and warning requirements of the application are met. The user must analyze all aspects of the application, follow applicable industry standards, and follow the information concerning the product in the current product catalog and in any other materials provided from Parker or its subsidiaries or authorized distributors.

To the extent that Parker or its subsidiaries or authorized distributors provide component or system options based upon data or specifications provided by the user, the user is responsible for determining that such data and specifications are suitable and sufficient for all applications and reasonably foreseeable uses of the components or systems.

Offer of Sale

The items described in this document are hereby offered for sale by Parker Hannifin Corporation, its subsidiaries or its authorized distributors. This offer and its acceptance are governed by the provisions stated in the "Offer of Sale".

Patent Information

The Chelsea® Power Take-Off or its components shipped with this owner's manual may be manufactured under one or more of the following U.S. patents:

4610175 5228355 4597301 5645363 6151975 6142274 6260682 7159701 B2 7,510,064
Other patents pending.

© Copyright 2010, Parker Hannifin Corporation, All Rights Reserved

General Information

Safety Information	1-2
Pump Support Recommendations	3
Foreword	4
Chelsea P.T.O. Safety Label Instructions	5-6
Function of Auxiliary Power Shafts	7
Spicer® Universal Joint Engineering Data	8

Allison Transmission Installation Instructions

Mounting 267, 269, 277, 278, 859 and 867 P.T.O. on the Allison Transmission	9-11
Pressure Port and Aperture Opening Identification	12
Hose Specifications by Transmission	12
Shift Installation w/o Electronic Overspeed Control Old Style Valve	13
Shift Installation w/o Electronic Overspeed Control New Style Valve	14
Shift Installation w/ Electronic Overspeed Control New Style Valve	15
Shift Installation with Remote Mount Solenoid	16
Shift Installation 277 Series with Remote Solenoid for Hino Model 338	17
GMT P.T.O. Connector	18
P.T.O./Combo Valve Installation Sketch 277/278 series Old Style Valve	19
P.T.O./Combo Valve Installation Sketch 277/278 series New Style Valve	20

Caterpillar Transmission Installation Instructions

Mounting 267, 269, 277, 278, 859 and 867 P.T.O. on the Caterpillar Transmission	21-23
Shift Installation Sketch without Overspeed Control	24
Shift Installation Sketch with Overspeed Control	25
Shift Installation Kit with Remote Mount Solenoid	26
Pressure Port Location and Hose Chart	27

Installation Instructions

"RY" Wet Spline Installation Sketch	28
"AF" Wet Spline Installation Sketch (267)	28
"AK" Wet Spline Installation Sketch	29
"AF" Wet Spline Installation Sketch (277/278) Old Style Valve	30
"AF" Wet Spline Installation Sketch (277/278) New Style Valve	31
"XY" Wet Spline Installation Sketch	32
"ZY" Wet Spline Installation Sketch	33
Capscrew Installation	34
Rotatable Flange Torque Specifications	34
P.T.O. Shifting Procedure & Precautions	35
P.T.O. Maintenance	38
Offer of Sale	39

Safety Information

These instructions are for your safety and the safety of the end user. Read them carefully until you understand them.

General Safety Information

To prevent injury to yourself and/or damage to the equipment:

- Read carefully all owner's manuals, service manuals, and/or other instructions.
- Always follow proper procedures, and use proper tools and safety equipment.
- Be sure to receive proper training.
- Never work alone while under a vehicle or while repairing or maintaining equipment.
- Always use proper components in applications for which they are approved.
- Be sure to assemble components properly.
- Never use wornout or damaged components.
- Always block any raised or moving device that may injure a person working on or under a vehicle.
- Never operate the controls of the Power Take-Off or other driven equipment from any position that could result in getting caught in the moving machinery.

Proper Matching of P.T.O.

 **WARNING:** A Power Take-Off must be properly matched to the vehicle transmission and to the auxiliary equipment being powered. An improperly matched Power Take-Off could cause severe damage to the vehicle transmission, the auxiliary driveshaft, and/or to the auxiliary equipment being powered. **Damaged components or equipment could malfunction causing serious personal injury to the vehicle operator or to others nearby.**

To avoid personal injury and/or equipment damage:

- Always refer to Chelsea catalogs, literature, and owner's manuals. Follow Chelsea recommendations when selecting, installing, repairing, or operating a Power Take-Off.
- Never attempt to use a Power Take-Off not specifically recommended by Chelsea for the vehicle transmission.
- Always match the Power Take-Off's specified output capabilities to the requirements of the equipment to be powered.
- Never use a Power Take-Off whose range of speed could exceed the maximum.

Cold Weather Operation of Powershift P.T.O.

 **WARNING:** During extreme cold weather operation [32°F (0°C) and lower], a disengaged Powershift Power Take-Off can momentarily transmit high torque that will cause unexpected output shaft rotation. This is caused by the high viscosity of the transmission oil when it is extremely cold. As slippage occurs between the Power Take-Off clutch plates, the oil will rapidly heat up and the viscous drag will quickly decrease.

The Power Take-Off output shaft rotation could cause unexpected movement of the driven equipment resulting in serious personal injury, death, or equipment damage.

To avoid personal injury or equipment damage:

- Driven equipment must have separate controls.
- The driven equipment must be left in the disengaged position when not in operation.
- Do not operate the driven equipment until the vehicle is allowed to warm up.

 This symbol warns of possible personal injury.

Safety Information (Continued)

Rotating Auxiliary Driveshafts

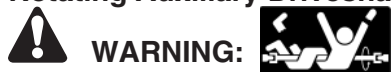

WARNING:

- Rotating auxiliary driveshafts are dangerous. You can snag clothes, skin, hair, hands, etc. This can cause serious injury or death.
- Do not go under the vehicle when the engine is running.
- Do not work on or near an exposed shaft when the engine is running.
- Shut off the engine before working on the Power Take-Off or driven equipment.
- Exposed rotating driveshafts must be guarded.

Guarding Auxiliary Driveshafts

 **WARNING:** We strongly recommend that a Power Take-Off and a directly mounted pump be used to eliminate the auxiliary driveshaft whenever possible. If an auxiliary driveshaft is used and remains exposed after installation, it is the responsibility of the vehicle designer and P.T.O. installer to install a guard.

Using Set Screws

 **WARNING:** Auxiliary driveshafts may be installed with either recessed or protruding set screws. If you choose a square head set screw, you should be aware that it will protrude above the hub of the yoke and may be a point where clothes, skin, hair, hands, etc. could be snagged. A socket head set screw, which may not protrude above the hub of the yoke, does not permit the same amount of torquing as does a square head set screw. Also, a square head set screw, if used with a lock wire, will prevent loosening of the screw caused by vibration. Regardless of the choice made with respect to a set screw, an exposed rotating auxiliary driveshaft must be guarded.

Important: Safety Information and Owner's Manual

Chelsea Power Take-Offs are packaged with safety information decals, instructions, and an owner's manual. These items are located in the envelope with the P.T.O. mounting gaskets. Also, safety information and installation instructions are packaged with some individual parts and kits. **Be sure to read the owner's manual before installing or operating the P.T.O.** Always install the safety information decals according to the instructions provided. Place the owner's manual in the vehicle glove compartment.

 **WARNING: Operating the P.T.O. with the Vehicle in Motion**

Some Power Take-Offs may be operated when the vehicle is in motion. To do so, the P.T.O. must have been properly selected to operate at highway speeds and correctly matched to the vehicle transmission and the requirements of the driven equipment.

If in doubt about the P.T.O. specifications and capabilities, avoid operating the P.T.O. when the vehicle is in motion. Improper application and/or operation can cause serious personal injury or premature failure of the vehicle, the driven equipment, and/or the P.T.O.

Always remember to disengage the P.T.O. when the driven equipment is not in operation.

Pump Installation Precautions

Use a bracket to support the pump to the transmission if:

- The pump weighs **40 pounds [18.4 kg]** or more.
- The combined length of the P.T.O. and pump is **18 inches [45.72 cm]** or more from the P.T.O. centerline to the end of the pump.

 This symbol warns of possible personal injury.

Direct Mount Pump Support Recommendations

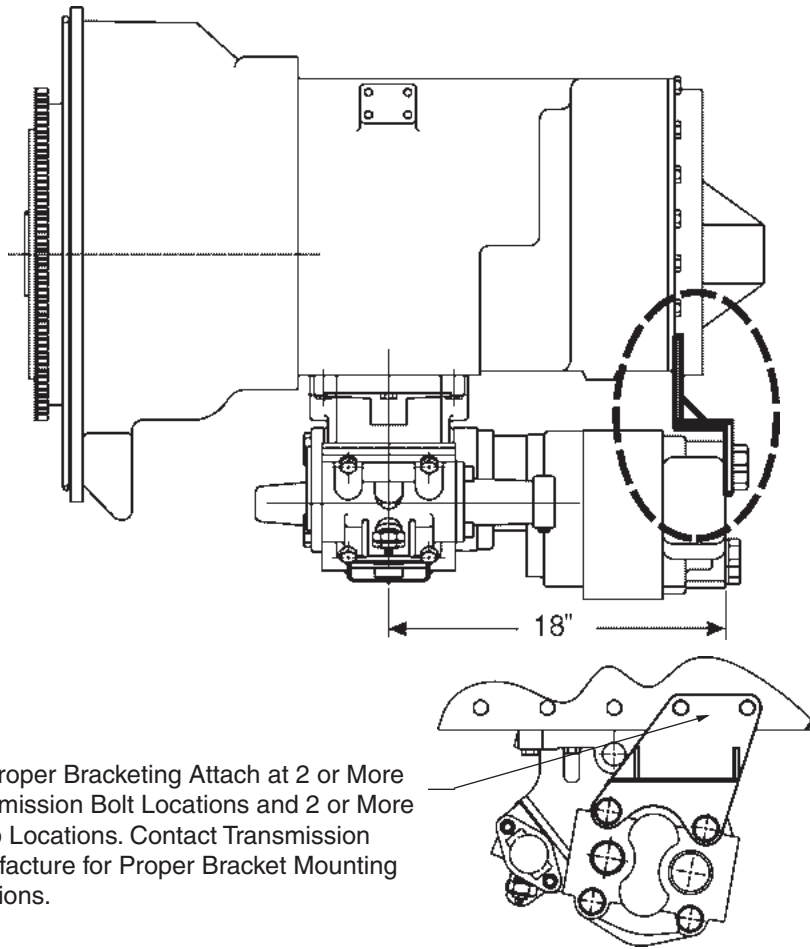

NOTE: For Proper Bracketing Attach at 2 or More Transmission Bolt Locations and 2 or More Pump Locations. Contact Transmission Manufacture for Proper Bracket Mounting Locations.



Use caution to ensure that bracket does not pre-load pump/P.T.O. mounting

Chelsea strongly recommends the use of pump supports (Support Brackets) in all applications. P.T.O. warranty will be void if a pump bracket is not used when:

- 1) The combined weight of pump, fittings and hose exceed **40 pounds [18.14 kg]**.
- 2) The combined length of the P.T.O. and pump is **18 inches [45.72 cm]** or more from the P.T.O. centerline to the end of the pump.

ALSO: Remember to pack the female pilot of the P.T.O. pump shaft with grease before installing the pump on the P.T.O. (reference Chelsea grease pack 379688)



This symbol warns of possible personal injury.

Foreword

Since our major objective is to show you how to get additional and more profitable miles from truck, tractor and trailer components, we want to provide you with information on the installation of Chelsea Power Take-Offs.

We all realize that an inadequate transmission will overwork any Power Take-Off in a very short period of time. In addition, a mismatched transmission/P.T.O. combination can result in unsatisfactory performance of the equipment right from the start.

Before you order new trucks, be sure you're getting the right transmission/P.T.O. combination. It is of vital importance for efficient performance to have adequate power. To help you select the proper type, size and design of P.T.O. it is advisable to discuss your specific requirements with Chelsea P.T.O. specialists. They know their products and have easy access to manufacturers of equipment, transmissions and Power Take-Offs. They can inform you about everything you need to know about power, at the right time, before you specify components.

Exploded View of a Typical Powershift P.T.O.

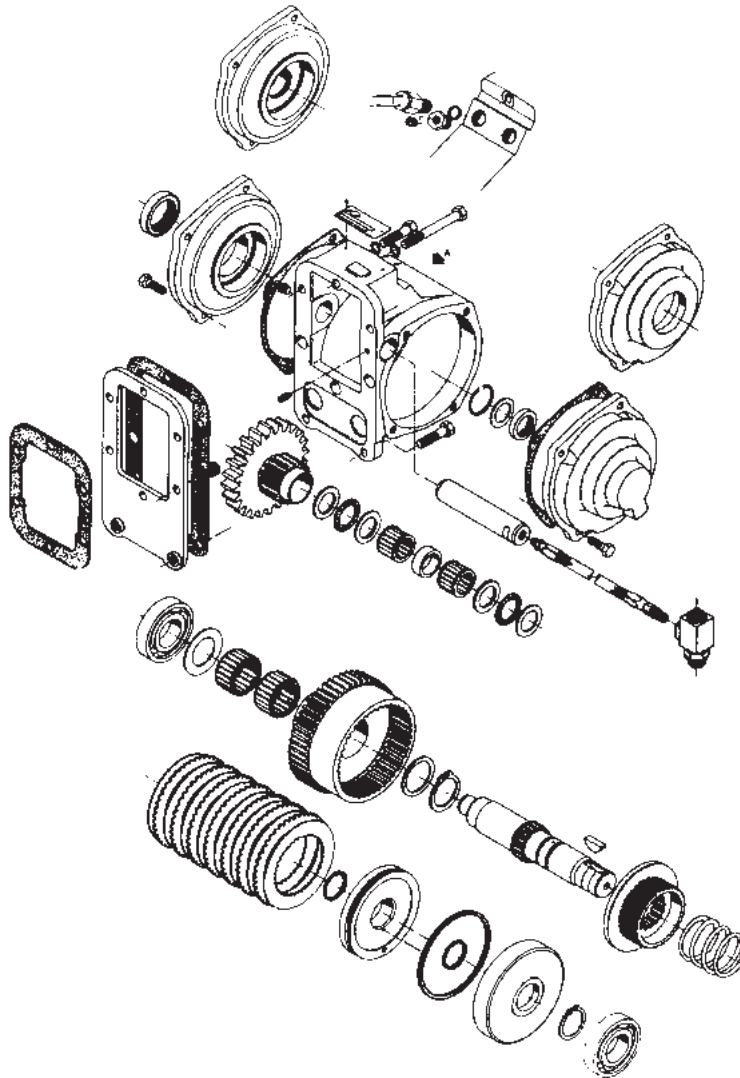

Chelsea P.T.O. Safety Label Instructions

1. The two black and orange on white 5" x 7" pressure sensitive vinyl labels, part number 379274; must be placed on the vehicle frame rails (one (1) on each side), in a position that would be **HIGHLY** visible to anyone that would go under the truck near the P.T.O. rotating shaft. If the vehicle is to be painted after these labels are installed, cover them with two (2) blank masking covers. Remove the masking covers after painting.
2. Place the one (1) black and orange on white 3.5" x 5" pressure sensitive vinyl label, part number 379275, on the visor nearest the operator of the vehicle, this must be placed near the P.T.O. visor label.
3. Place the one (1) red and white with black lettering 3.5" x 7.5" pressure sensitive vinyl label, part number 379915, on the opposite side of the visor from the above label # 379275.
4. Place the one (1) white and black heavy duty card, part number 379276, in the vehicle glove box. Again in a position highly visible to the operator, for example: try to place this card on top of whatever may be in the glove box.

If you require labels, please order part number 328946X at no charge from your local Chelsea Warehouse or send request direct to:

**Parker Hannifin Corporation
Chelsea Products Division
8225 Hacks Cross Road
Olive Branch, MS 38654
Customer Service: (662) 895-1011**

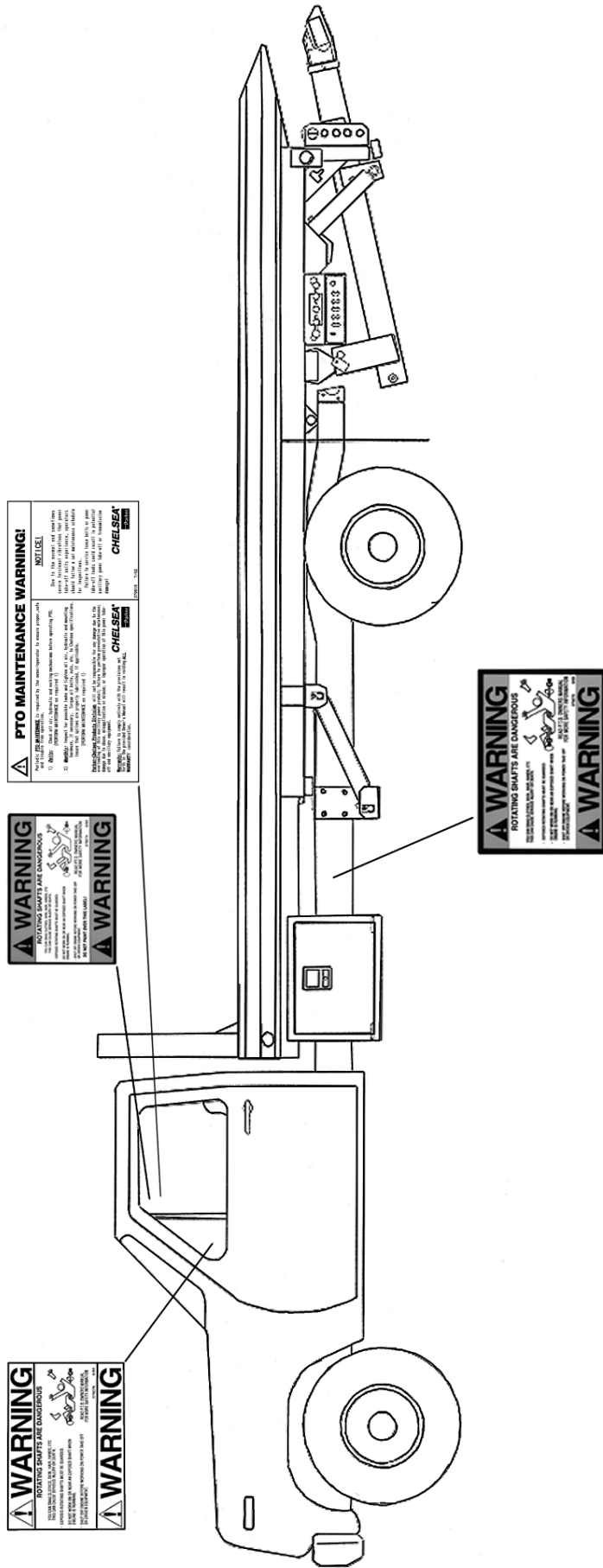

Function of Auxiliary Power Shafts

An auxiliary power shaft transmits torque from the power source to the driven accessory. The shaft must be capable of transmitting the maximum torque and R.P.M. required of the accessory, plus any shock loads that develop.

An auxiliary power shaft operates through constantly relative angles between the power source and the driven accessory, therefore, the length of the auxiliary power shaft must be capable of changing while transmitting torque. This length change, commonly called "slip movement", is caused by movement of the power train due to torque reactions and chassis deflections.

Joint operating angles are very important in an auxiliary power joint application. In many cases, the longevity of a joint is dependent on the operating angles. (See chart below)

This information is limited to 1000 through 1310 series applications. For applications requiring a series larger than 1310, contact your local Chelsea distributor.

Determining Shaft Type

- 1) Solid or tubular?
 - a) In applications requiring more than 1000 R.P.M. or where the application necessitates a highly balanced auxiliary power shaft, a tubular shaft should be used.
 - b) Spicer's solid shafting auxiliary power joints are designed for 1000 or less R.P.M. intermittent service such as:
 - Driving small hydraulic pumps
 - Driving winches
 - Driving low speed product pumps
- 2) Joint Series should be determined using the chart on the following page.

Spicer® Universal Joint Operating Angles			
Prop. Shaft R.P.M.	Max. Normal Operating Angle	Prop. Shaft R.P.M.	Max. Normal Operating Angle
3000	5° 50'	1500	11° 30'
2500	7° 00'	1000	11° 30'
2000	8° 40'	500	11° 30'

Above based on angular acceleration of 100 RAD/SEC²

Spicer® Universal Joint Engineering Data

Joint Series	1000	1100	1280	1310
Torque Rating Automotive (Gas or Diesel Engine) Lbs. ft. Continuous	50	54	95	130
Tubing Diameter Wall Thickness W = Welded S = Seamless	1.750 .065 W	1.250 .095 S	2.500 .083 W	3.00 .083 W
Flange Diameter (Swing Diameter) Rectangular Type	3.500	3.500	3.875	3.875
Bolt Holes - Flange Yoke Circle Diameter Number Male Pilot Dia.	2.750 .312 4 2.250	2.750 .312 4 2.250	3.125 .375 4 2.375	3.125 .375 4 2.375
Distance Across Lugs Snap Ring Construction	2.188	2.656	3.469	3.469
Bearing Diameter	.938	.938	1.062	1.062

Maximum Operating Speed * By Tube Size, Solid Shaft Size, and Length *(For speed below 500 R.P.M. or over 2500 R.P.M., contact your Chelsea Distributor)					
Tubing Dia. & Wall Thickness Joint & Shaft (W=Welded S=Seamless)	Max. Installed Length in Inches for Given R.P.M. Centerline to Centerline of Joints for a Two Joint Assembly or Centerline of Joint to Centerline of Center Bearing for a Joint & Shaft R.P.M. - Revolutions per Minute				
	500	1000	1500	2000	2500
1.750" X .065" W	117"	82"	67"	58"	52"
1.250" X .095" S	91"	64"	52"	45"	40"
2.500" X .083" W	122"	87"	70"	62"	55"
3.000" X .083" W	-	-	-	85"	76"
Solid Shaft Diameter					
.750"	60"	42"	35"	30"	27"
.812"	62"	44"	36"	31"	28"
.875"	65"	46"	37"	32"	29"
1.000"	69"	49"	40"	35"	31"
1.250"	77"	55"	45"	39"	35"

Mounting the P.T.O. on the Transmission

When installing a P.T.O., always wear protective clothing and safety glasses.

1. Begin by draining the oil from the transmission. Use caution, since the oil may be hot (**Fig. 1**).

NOTE: Installation shown is for Right Side (Street Side) of Transmission.



Fig. 1

2. Remove the P.T.O. aperture plate with a 15mm socket (**Fig. 2**).

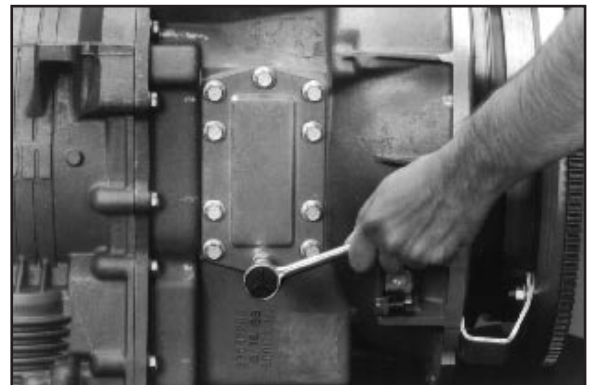

Fig. 2

3. Remove the gasket and clean the aperture surface (**Fig. 3**).

NOTE: Do not reuse the gasket that comes with the transmission.

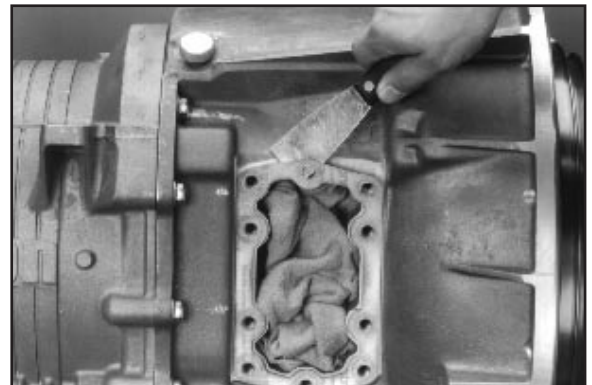

Fig. 3

4. Using a screwdriver, install the guide pins until they bottom out (**Fig. 4**) (Refer to [Page 34](#) for correct location and use).

NOTE: Do not use sealing compounds because they are generally incompatible with automatic transmission fluid.

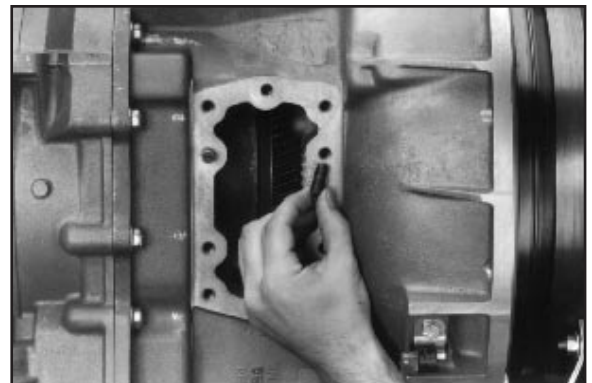

Fig. 4

Mounting the P.T.O. on the Transmission (Continued)

5. Install the special gasket over the guide pins. The ribbed surface should face outward, toward the installer (**Fig. 5**).

NOTE: To ensure proper backlash and sealing of P.T.O. to transmission only use gasket furnished with the P.T.O.

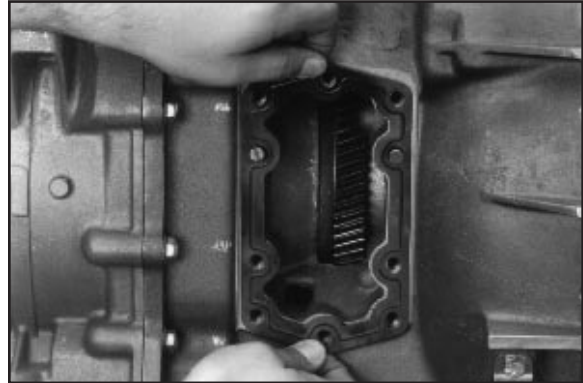

Fig. 5

6. Position the P.T.O. and secure it with the top capscrew (**Fig. 6**).

NOTE: Refer to page 34 for proper capscrew installation for the 269 & 278 Series

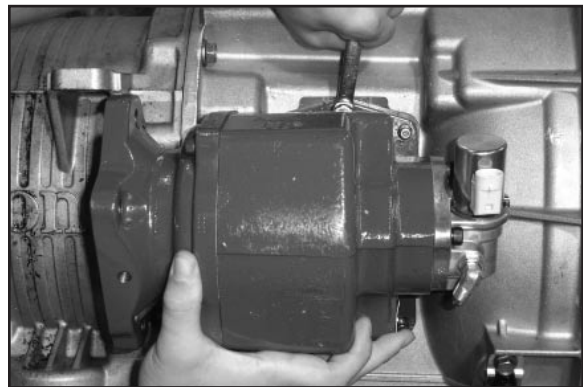

Fig. 6

7. Install the remaining capscrews. Torque all to 40 - 50 Lbs. ft. (54 - 68 N.m. or 5.5 - 6.9 Kg.m) (**Fig. 7**).

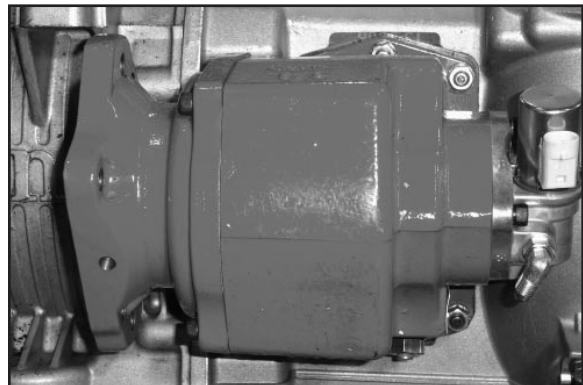

Fig. 7

8. Install P.T.O. pressure switch, part # 379502, into port on Hydraulic Valve Cap. Torque to 120-140 In-lbs (**Fig. 8**).

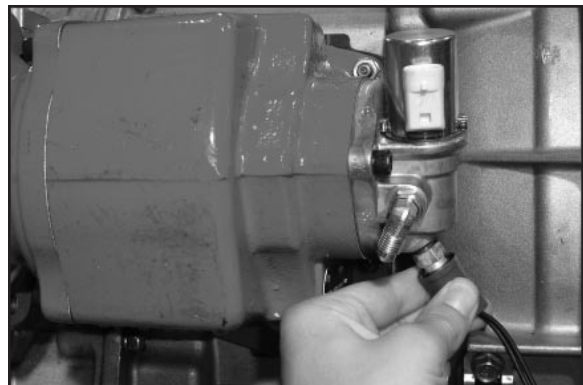

Fig. 8

Mounting the P.T.O. on the Transmission (Continued)

9. If using a rotatable flange see [page 34](#) for bolt torque specifications. (**Fig. 9**).

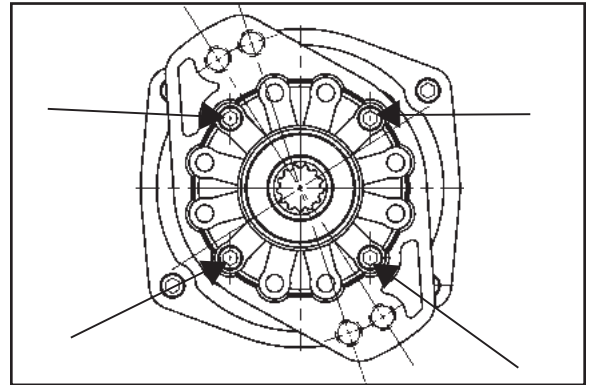

Fig. 9

10. Securely attach the high pressure line to the P.T.O. valve (**Fig. 10**).



Fig. 10

11. Use the special fitting to securely attach the high pressure line to the transmission. This fitting is included with the P.T.O. (**Fig. 11**). See the chart on [page 12](#) for the correct hose specifications. With the hose and P.T.O. securely connected, refill the transmission to the manufacturer's suggested specifications.

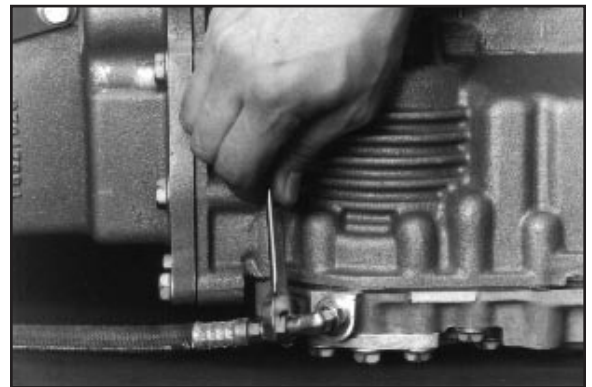

Fig. 11 (Right side shown)

12. Complete the assembly by installing the electrical connection to the valve assembly (**Fig. 12**) and the pressure switch (**Fig 13**).

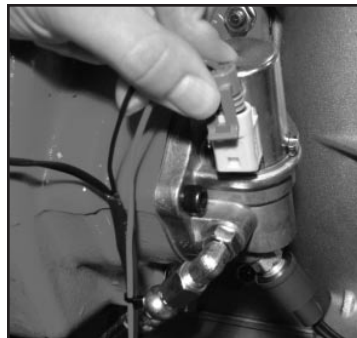

Fig. 12



Fig. 13

Pressure Port and Aperture Opening Identification

1. These drawings represent left and right views of the MD and HD pressure ports on the transmission.

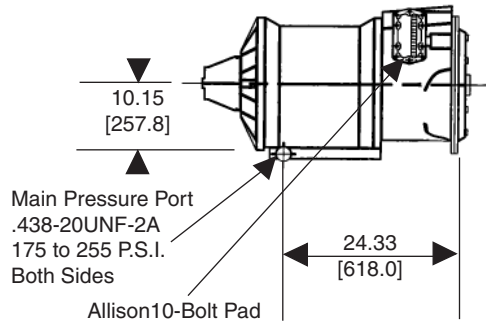

MD
 Top/Left

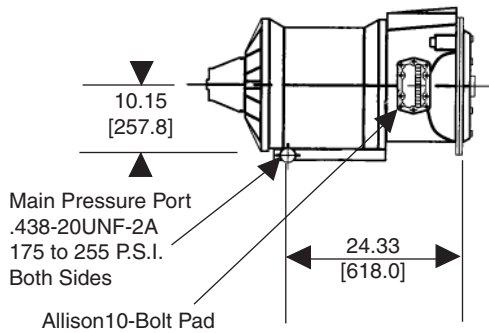
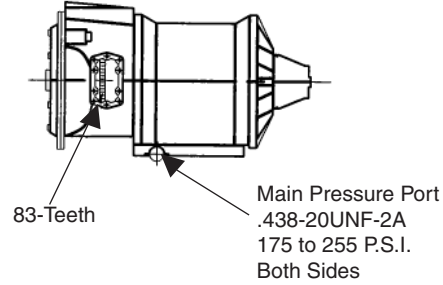

MD
 Right/Left

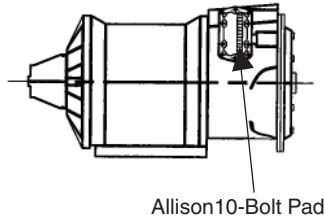
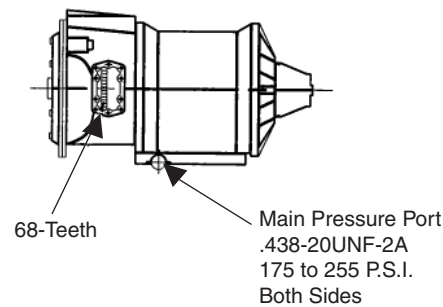

HD
 Top/Left

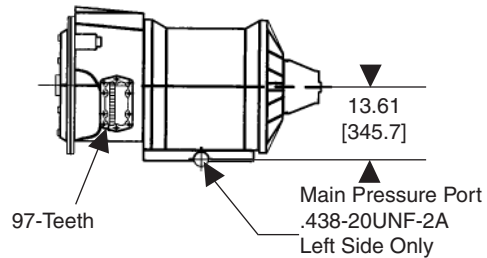

Standard Hose Specifications by Transmission

TRANS.	LOCATION	267 Series	277 Series	278 Series	859 Series
MD	Top Right (Right Press. Port)	329130-6X	329075-2X	329075-2X	329075-2X
MD	L.H. Side (Left Press. Port)	329130-1X	329130-5X	329130-5X	329130-5X
MD	R.H. Side (Right Press. Port)	329130-4X	329075-1X	329075-1X	329075-1X
HD	Top Right (Left Press. Port)	329130-6X	329075-2X	329075-2X	329075-2X
HD	L.H. Side (Left Press. Port)	329130-1X	329130-4X	329075-4X	329130-4X
HD ^{1,2}	L.H. Side (Left Press. Port)	—	329130-5X	329130-5X	329130-5X
HD ^{1,2}	Top Right (Right Press. Port)	—	329130-4X	329075-4X	329130-4X
MD ^{1,2}	L.H. Side (Left Press. Port)	—	329130-5X	329130-5X	329130-5X
MD ^{1,2}	R.H. Side (Right Press. Port)	—	329075-1X	329075-1X	329075-1X

An HD with 2 P.T.O.'s requires a 379556 "T" fitting and a 379703 swivel nut 90 degree elbow to attach 2 hoses to the single port on the left side.

1 Lubrication Option "R", shifter Options "G" and "H" for 277 and 859 Series

2 Lubrication Option "R" for 278 Series

**Shift Installation Kit 277, 278 & 859 Series without Electronic Overspeed Control
 (SK-347 Rev C) (Old Style)**

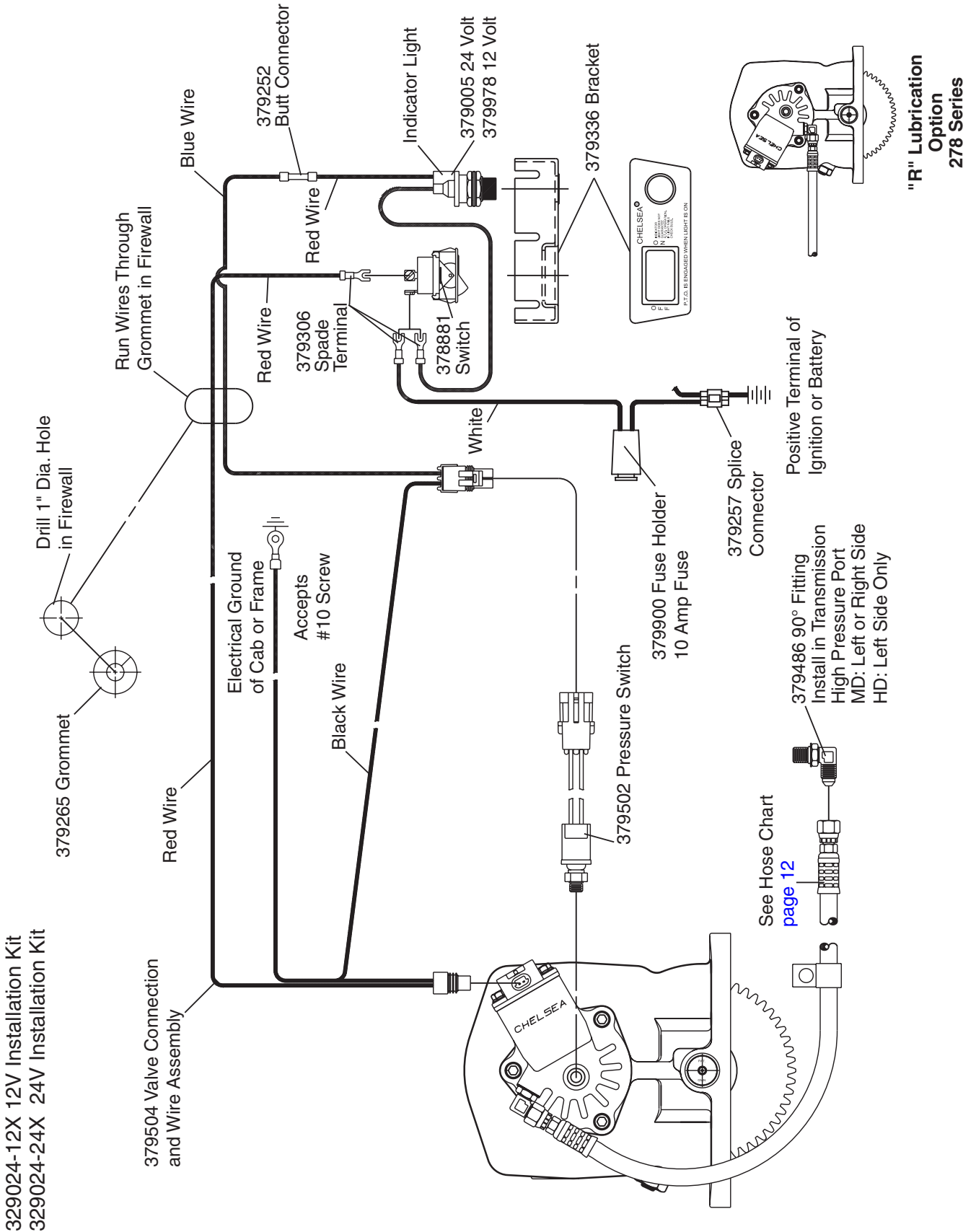

Shift Installation Kit 277, 278 & 859 Series with Electronic Overspeed Control (SK-472)

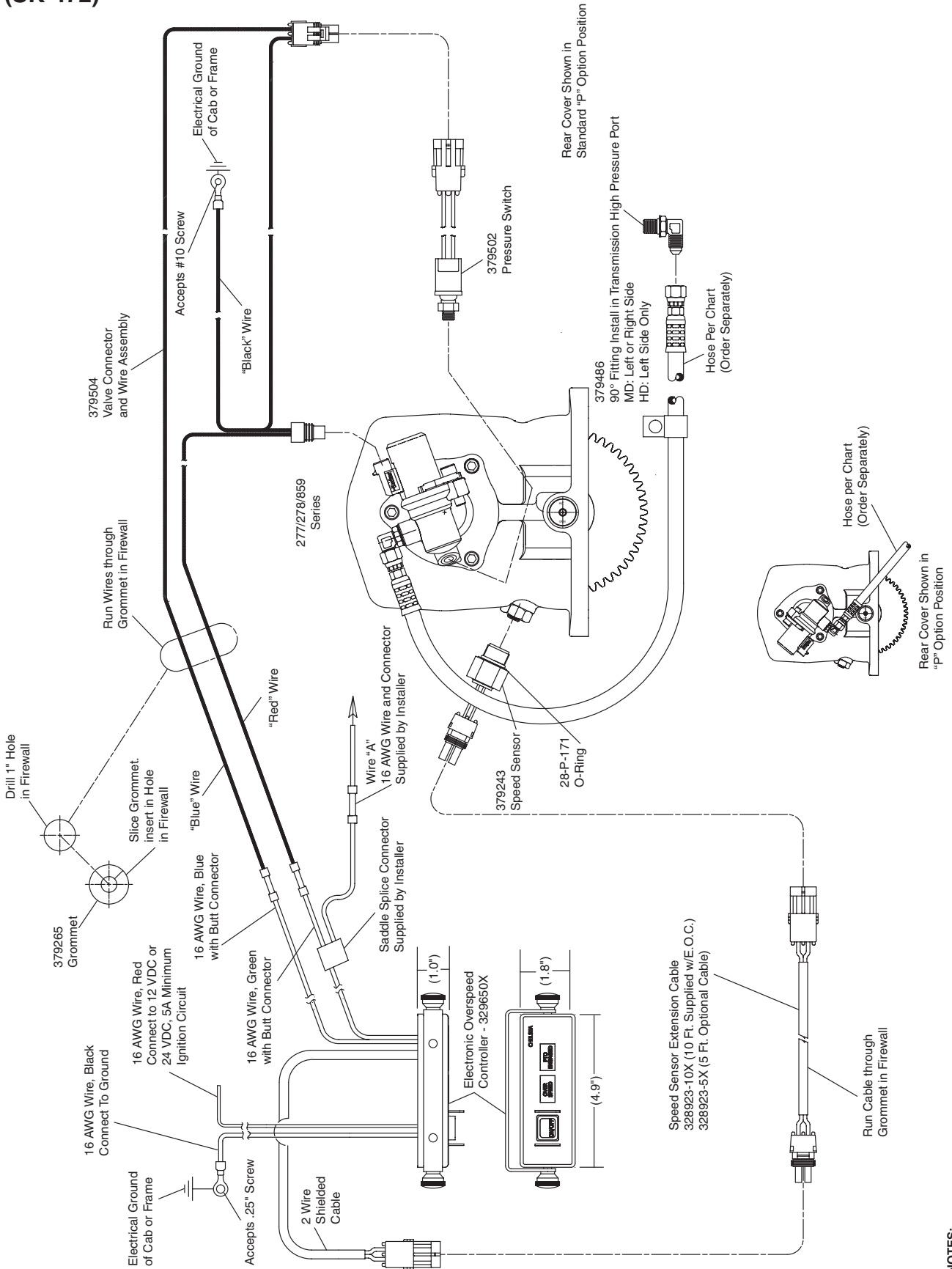

NOTES:
 1) Strip Wire Ends .25" Prior to Installing in Butt Connector (As Necessary)
 2) Reference Kit 325076X

**Shift Installation Kit 277 Series with Remote Mount Solenoid for Hino Model 338
 (SK-410 Rev C)**

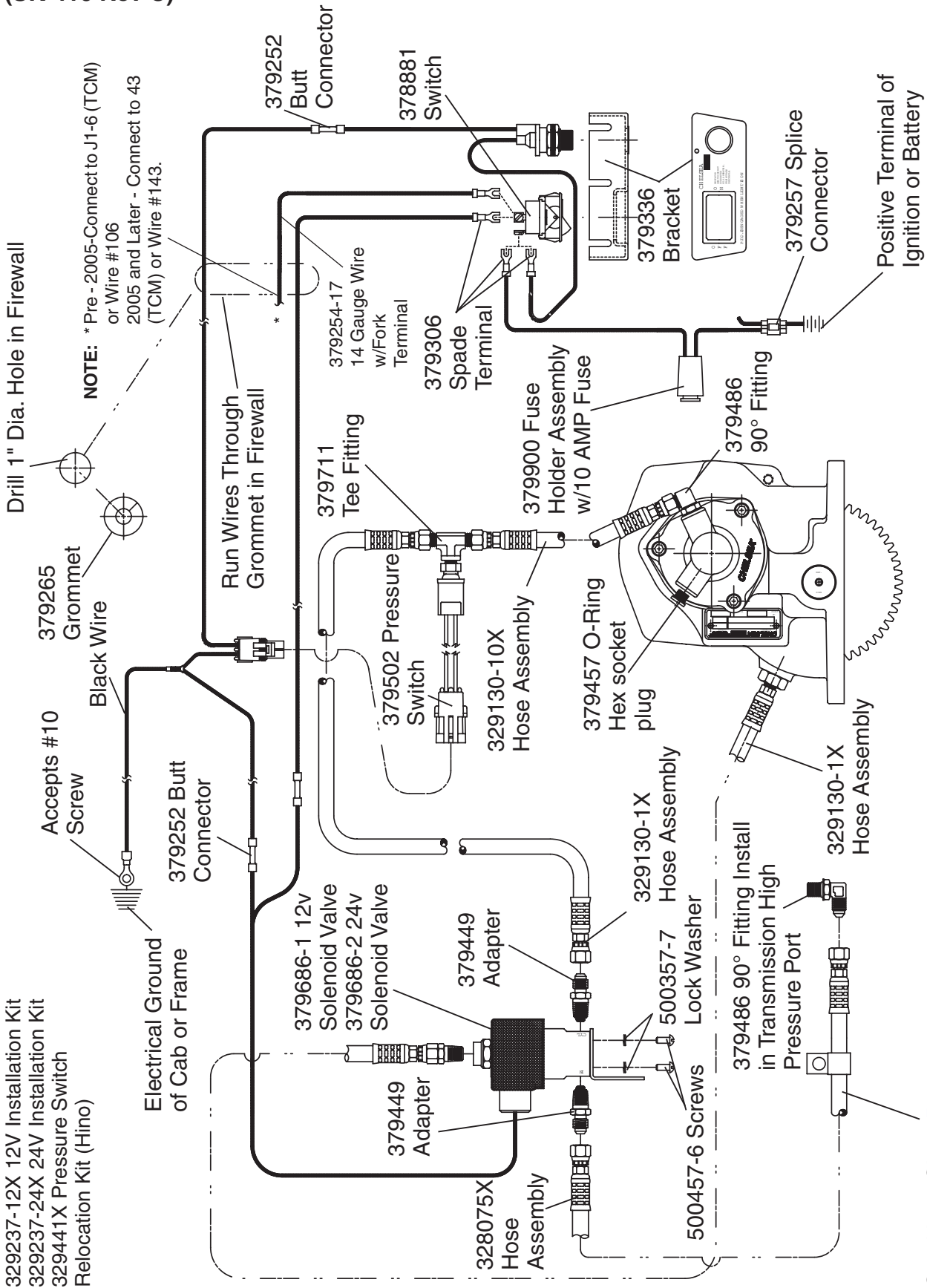

GMT C Series Trucks

For model year 2003 GM C Series 4500, 5500, 6500, 7500 and 8500 trucks may be equipped with the Allison World (MD) transmission. In these vehicles GM Truck has integrated a P.T.O. connector, located in the right hand engine compartment area. A Power Take-Off switch has also been incorporated into the GM dash panel to control P.T.O. operation. With the P.T.O. option ordered on the truck, the P.T.O. connector and in-dash switch simplify the interface for the body builder.

In order for the customer to utilize the full capability of the P.T.O./transmission, Chelsea has design a wiring harness that must be used between the GM P.T.O. connector and the Chelsea Power Take-Off. These are for P.T.O. Non E.O.C. applications only.

On the Allison World (MD) transmission the P.T.O. drive gear is engine driven. The wiring harness is not "required" for the Power Take-Offs listed on the chart, but must be used if the GM supplied in-dash P.T.O. switch is to be utilized.

See wiring harness part number 379926 for the 277, 278 and 859 Series Power Take-Offs.

2003 GM "C" Series Wiring Harness for 277, 278 and 859 Series
Part Number 379926

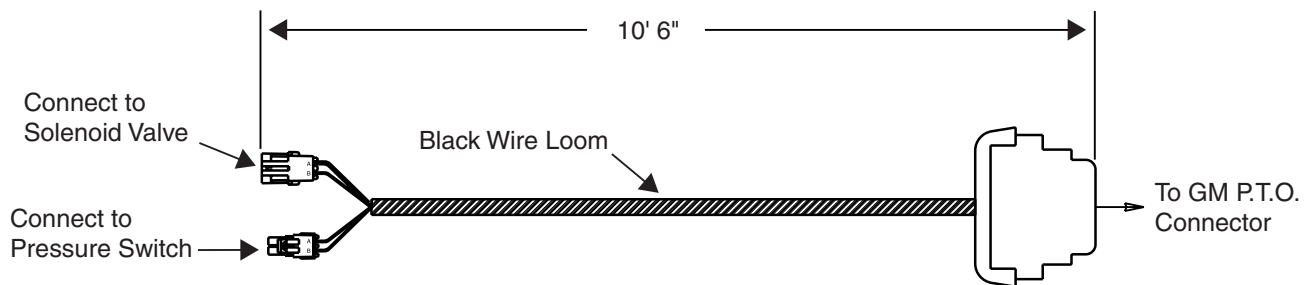

P.T.O. Combo Valve Installation Sketch, 277/278 Series (SK-427 Rev C) (New Style)

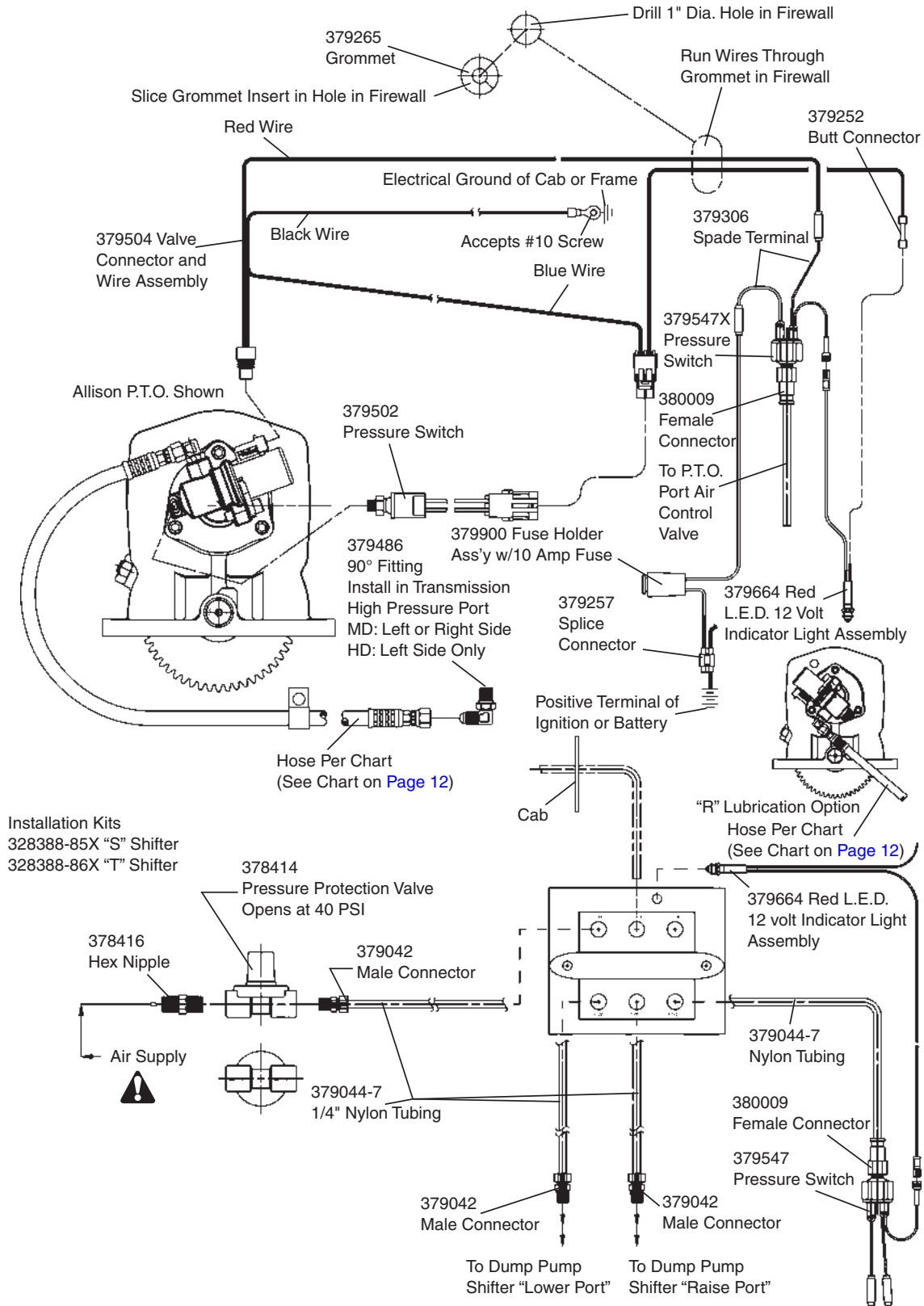

Warning: Connect directly to air supply. Do not use tubing between air supply and pressure protection valve.
Caution: When installing nylon tubing avoid sharp angles, exhaust and manifold systems.

Mounting the P.T.O. on the Transmission

When installing a P.T.O., always wear protective clothing and safety glasses.

1. Remove the P.T.O. aperture plate with a 16mm socket (**Fig. 1**).

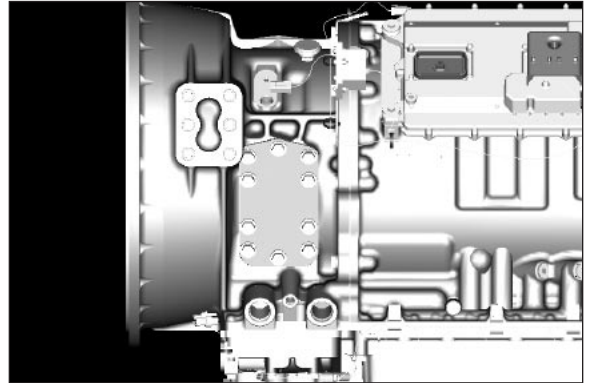

Fig. 1

2. Remove the gasket and clean the aperture surface (**Fig. 2**).

NOTE: Do not reuse the gasket that comes with the transmission.



Fig. 2

3. Using a screwdriver, install the guide pins until they bottom out (**Fig. 3**) (see [page 34](#)).

NOTE: Do not use sealing compounds because they are generally incompatible with automatic transmission fluid.

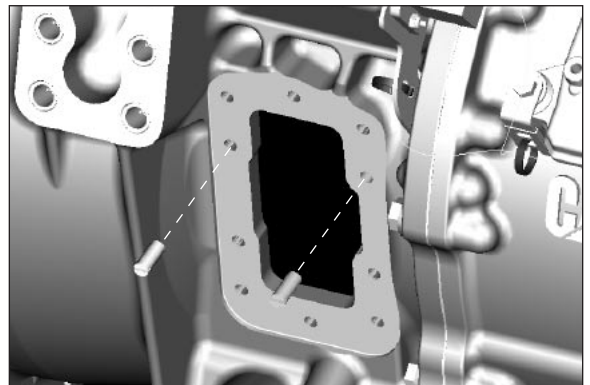

Fig. 3

4. Install the special gasket over the guide pins. The ribbed surface should face outward, toward the installer (**Fig. 4**).

NOTE: To ensure proper backlash and sealing of the P.T.O. to the transmission, only use Gasket furnished with the P.T.O.

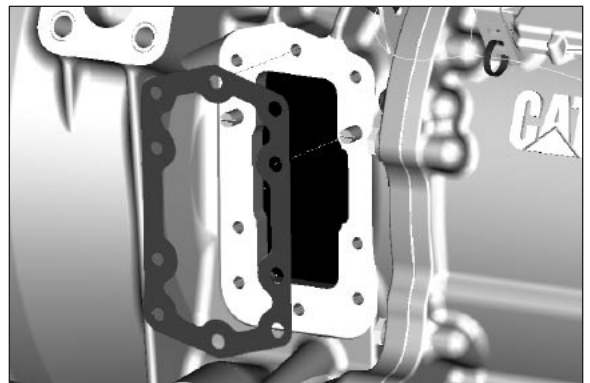

Fig. 4

Mounting the P.T.O. on the Transmission (Continued)

5. Position the P.T.O. and secure it with the top capscrew provided. (**Fig. 5**)

NOTE: Refer to [page 34](#) for proper capscrew installation for the 269 & 278 Series

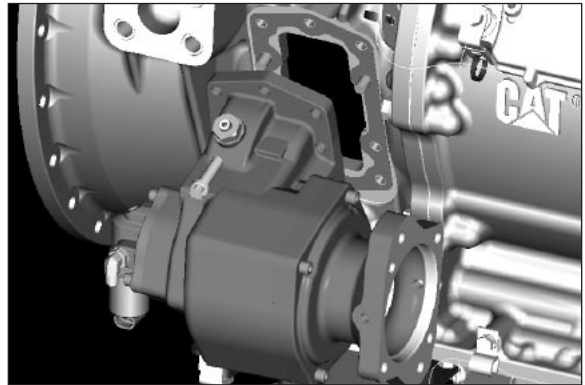

Fig. 5

6. Install the remaining capscrews. Torque them to 37-44 Lbs. ft. [50-60 N.m.] (**Fig. 6**).



Fig. 6

NOTE: There are two (2) high pressure ports available. Use the port located on the driver's side of the transmission unless there is an interference issue with a pump or driven object (**Fig. 7**).

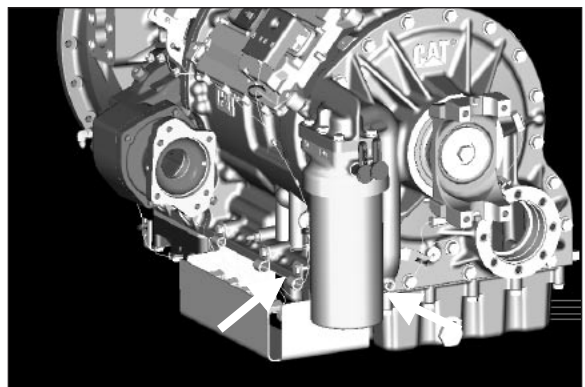

Fig. 7

7. Using the special fitting (379812) to securely attach the high pressure line to the transmission. This fitting is included with the P.T.O. Tighten to 8-10 Lbs. ft. [11.0 - 13.5 N.m.] (**Fig. 8**).

See the hose chart on [page 27](#) for the correct hose specifications. Tighten hose end fitting 2 flats from finger tight

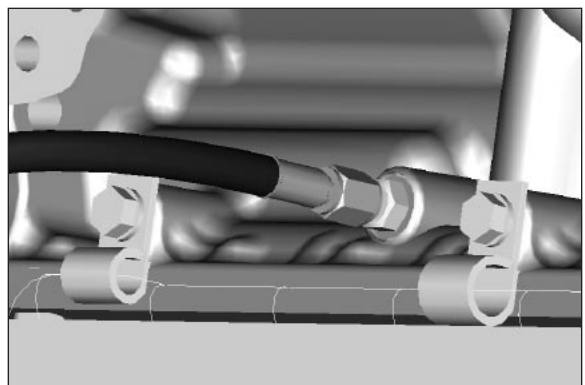

Fig. 8

Mounting the P.T.O. on the Transmission (Continued)

- Securely attach the high pressure line to the valve. Tighten hose end fitting 2 flats from finger tight (**Fig. 9**).

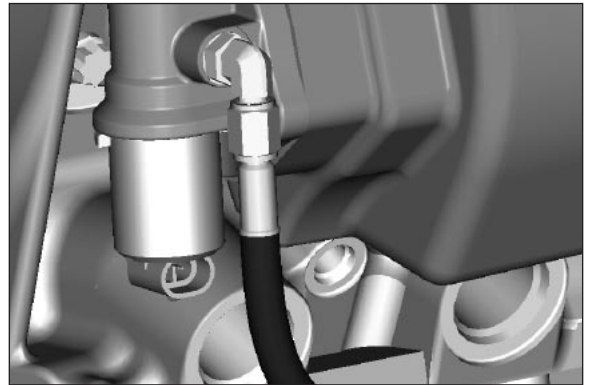

Fig. 9

- Complete the assembly by installing the electrical connection (**Fig. 10**).

NOTE: See [page 24-26](#) for electrical connection drawings.

NOTE: If using a rotatable flange, see [page 34](#) for bolt torque.

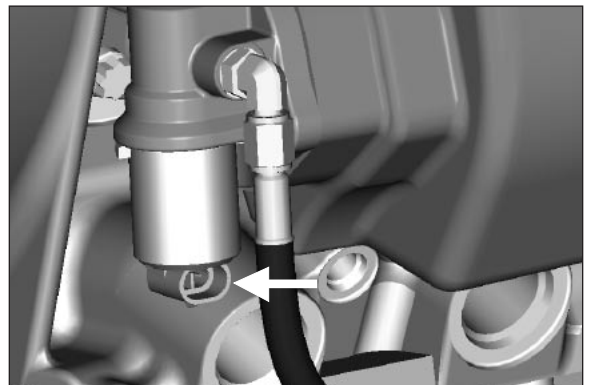
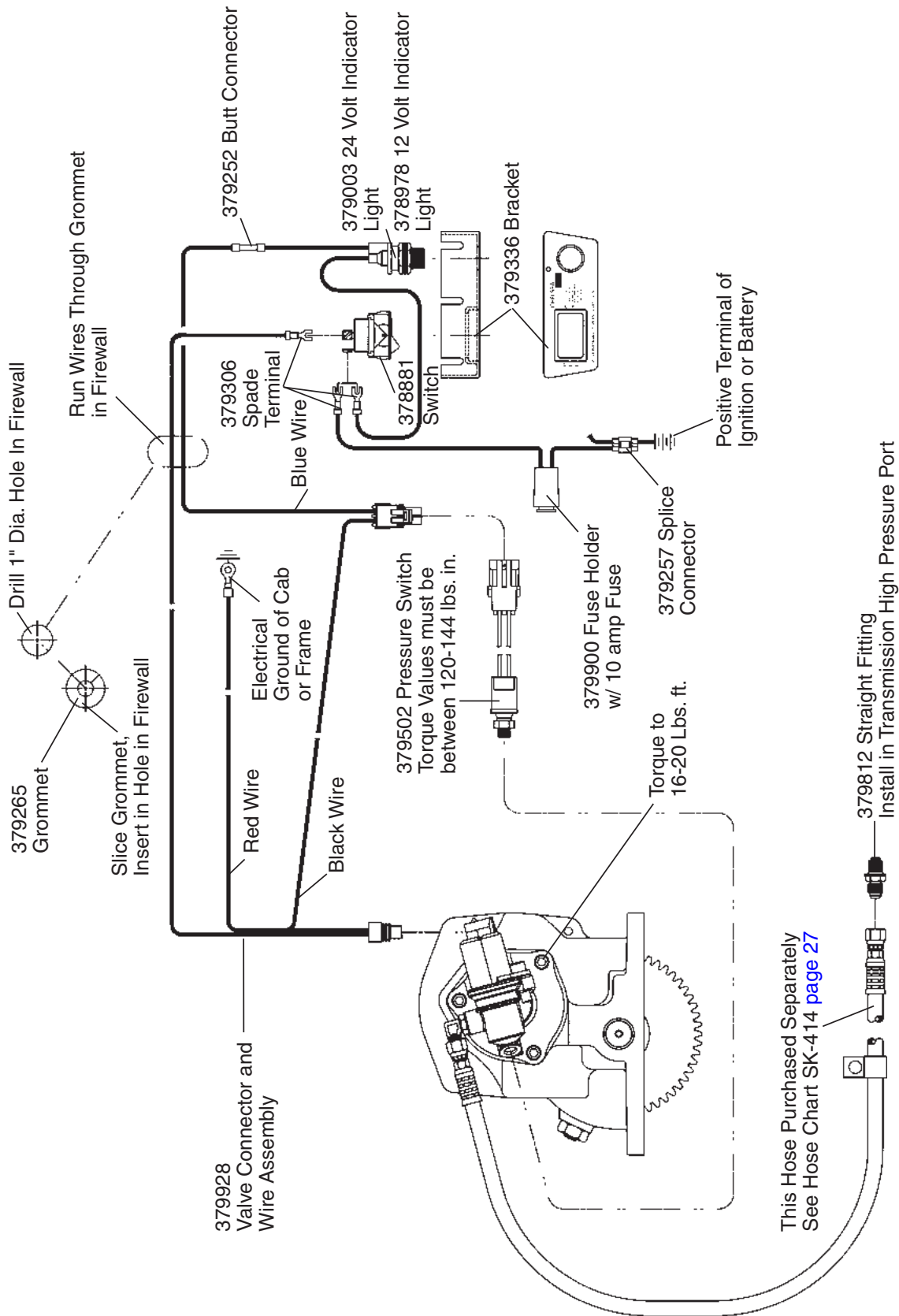

Fig. 10

**Shift Installation Kit 277, 278 and 859 Series without Electronic Overspeed Control
 (SK-411 Rev A)**



329443-12X - For 12V Installation Kit
 329443-24X - For 24V Installation Kit

Electronic Overspeed Control Installation Sketch for 277, 278 and 859 Series (SK-473)

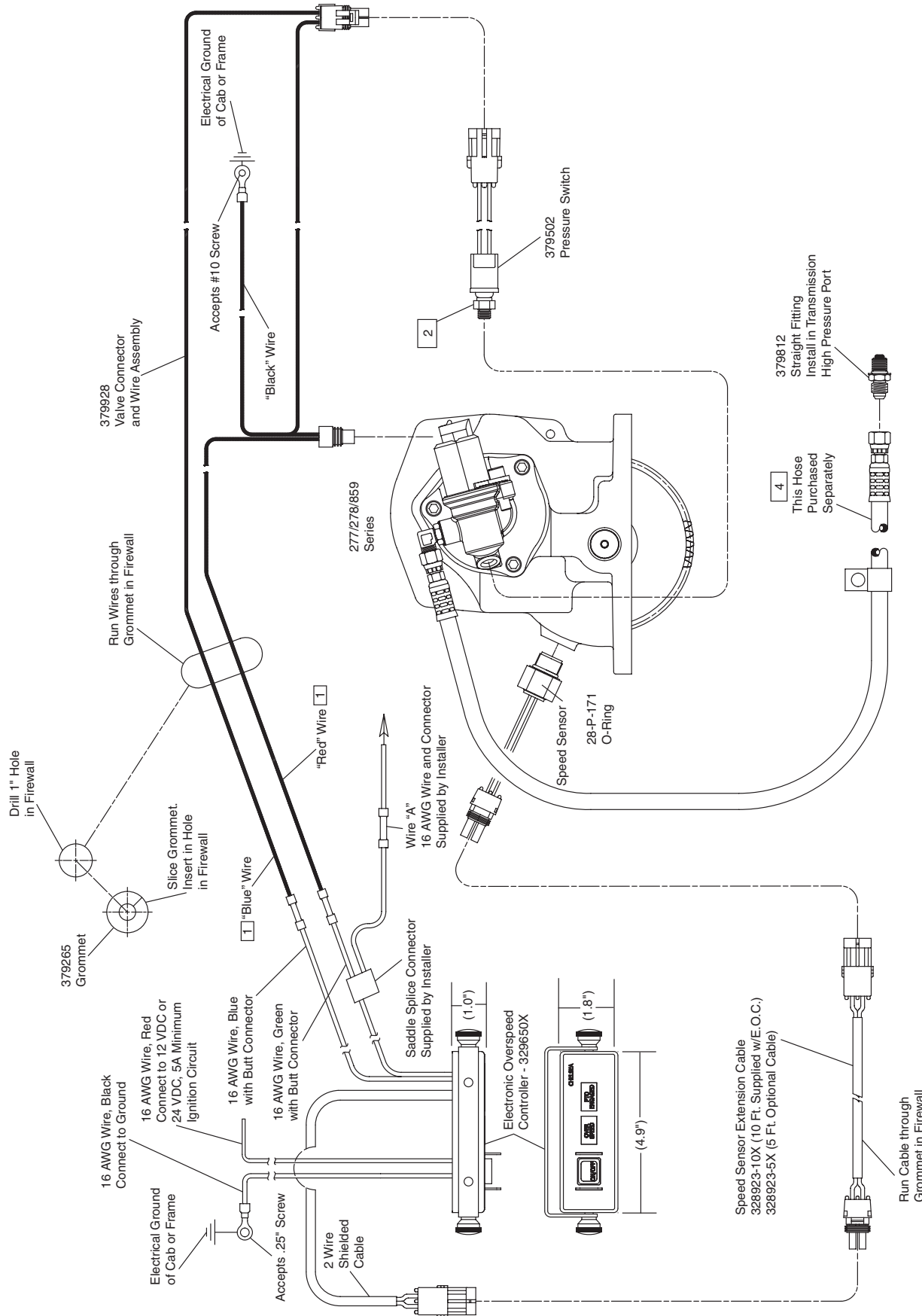

- NOTES:**
- 1) Strip Wire Ends .25" Prior to Installing in Butt Connector (As Necessary)
 - 2) Caution: Torque Values Must Be Maintained 120-144 Lb In
 - 3) Reference Kit: 329444X Installation Kit
 - 4) See Sk-414 For Hose Lengths

Remote Mount Installation Sketch for 277, 278 and 859 (SK-413 Rev C)

329445-12X 12V Installation Kit
 329445-24X 24V Installation Kit

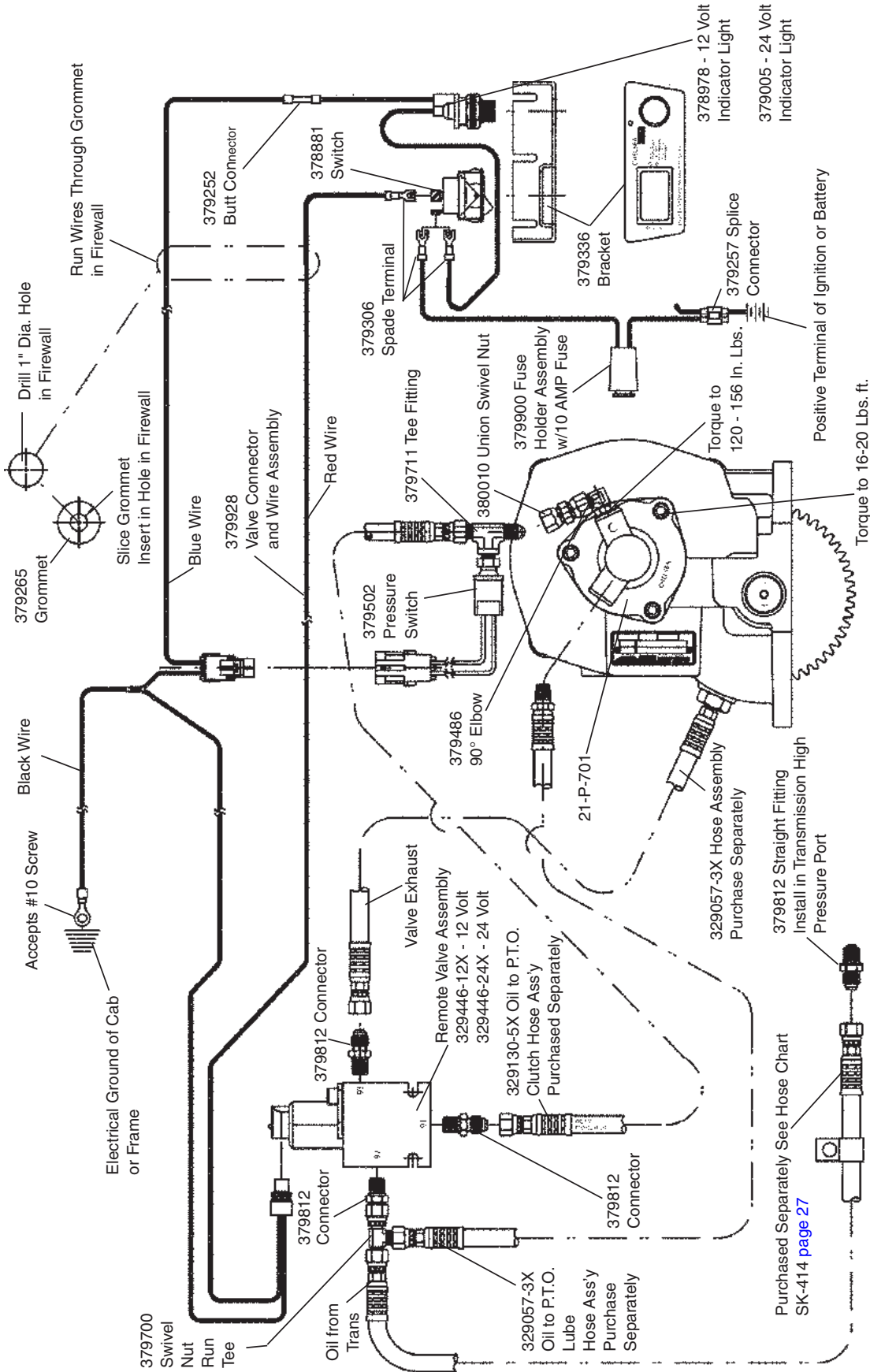

NOTE: This option is not available with, nor can it be used on E.O.C. applications.

Pressure Port Locations & Hose Chart (SK-414 Rev B)

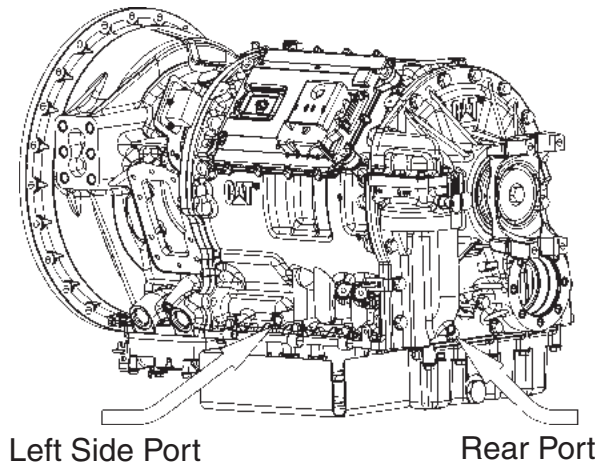

Left Side Port Rear Port

CX31

(Filter Removed for Clarity)

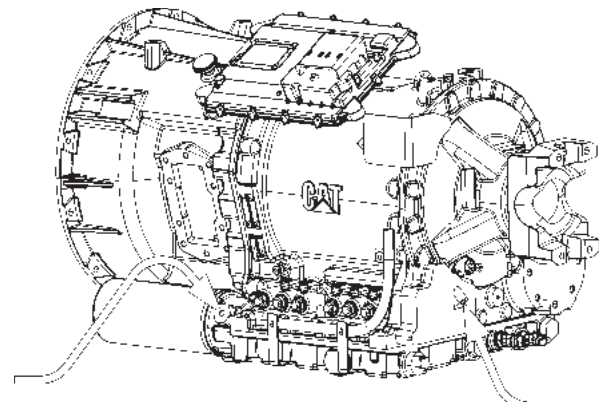

Left Side Port Rear Port

CX28

Both High Pressure Connections are -4 O-Ring Boss

HOSE CHART							
Trans.	P.T.O.	P.T.O. Location	High Oil Pressure Location	P.T.O. Valve Location	P.T.O. Fitting	Trans. Fitting	Trans.-P.T.O. Valve Hose #
CX31 CX28	277, 278 859	Driver (LHS)	LHS	Attached	379486	379812	329075-1X
		Driver (LHS)	Rear				329075-5X
		Pass. (RHS)	LHS			379486	329075-2X
		Pass. (RHS)	Rear				329075-5X
		Driver (LHS)	LHS	Remote	379486	379812	329130-6X
		Driver (LHS)	Rear				329130-6X
		Pass. (RHS)	LHS				329130-6X
		Pass. (RHS)	Rear				329130-6X
	267	Driver (LHS)	LHS	N/A	379486	379812	329130-3X
		Driver (LHS)	Rear			379486	329075-5X
		Pass. (RHS)	LHS			379812	329075-2X
		Pass. (RHS)	Rear			379812	329075-5X
867	Driver (LHS)	LHS	N/A	379486	379812	329130-3X	
	Driver (LHS)	Rear				329075-5X	
	Pass. (RHS)	LHS			379486	329075-2X	
	Pass. (RHS)	Rear				329075-5X	

LHS = Left Side of Transmission, 8 o'clock position
 RHS = Right Side of Transmission, 1 o'clock position

NOTES:

1. P.T.O. Fitting 379486 and Transmission Fitting 379812 included with the P.T.O. Unit. If Using 379486 in Transmission it Must be Purchased Separately
2. Hoses to be Purchased Separately
3. 379486 Elbow Will Not Install on Left Hand (Driver) Side Oil Port Due to Transmission Interference
4. If 379486 is Listed as Transmission Fitting for Rear Location, Route Hose Along Right Hand (passenger) Side of Transmission and Under Transmission Output Yoke

CAUTION: Wet Spline Options Must be used with a Pump that has a Contiguous Sealing surface to Ensure a proper seal between Pump and P.T.O.

Installation "RY" Wet 267 Series (SK-351 Rev C)

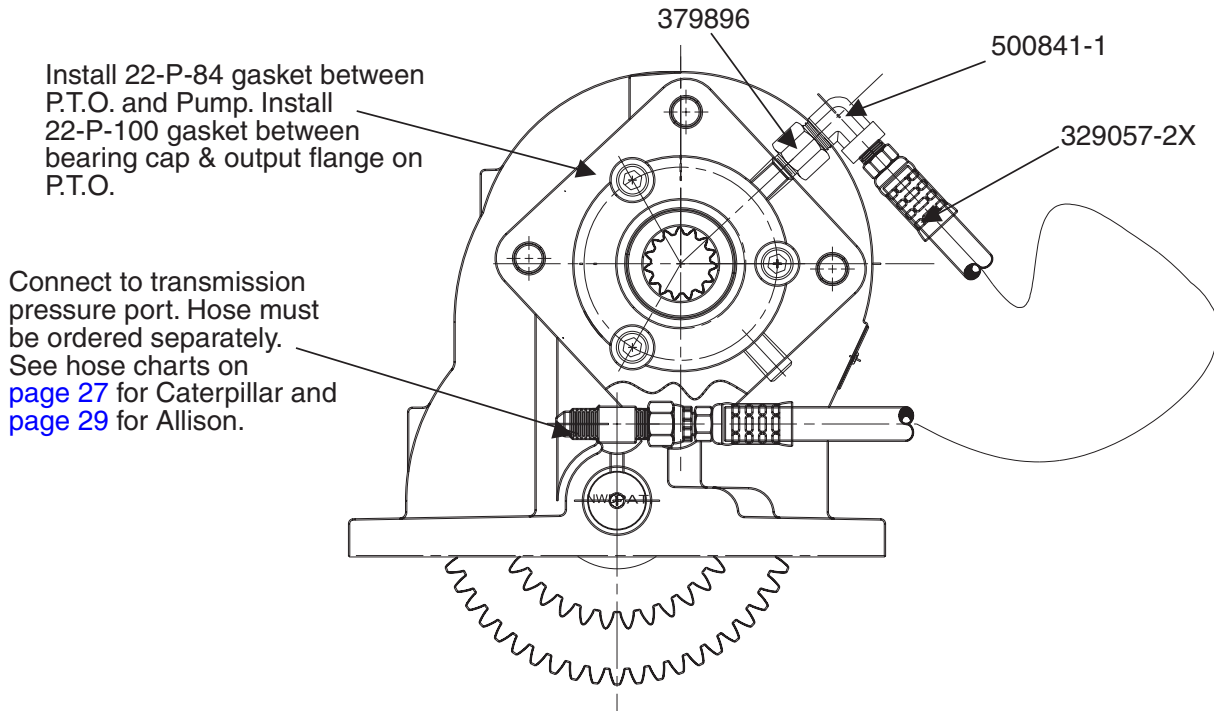

Installation "AF" Wet Spline 267 Series (SK-350 Rev C)

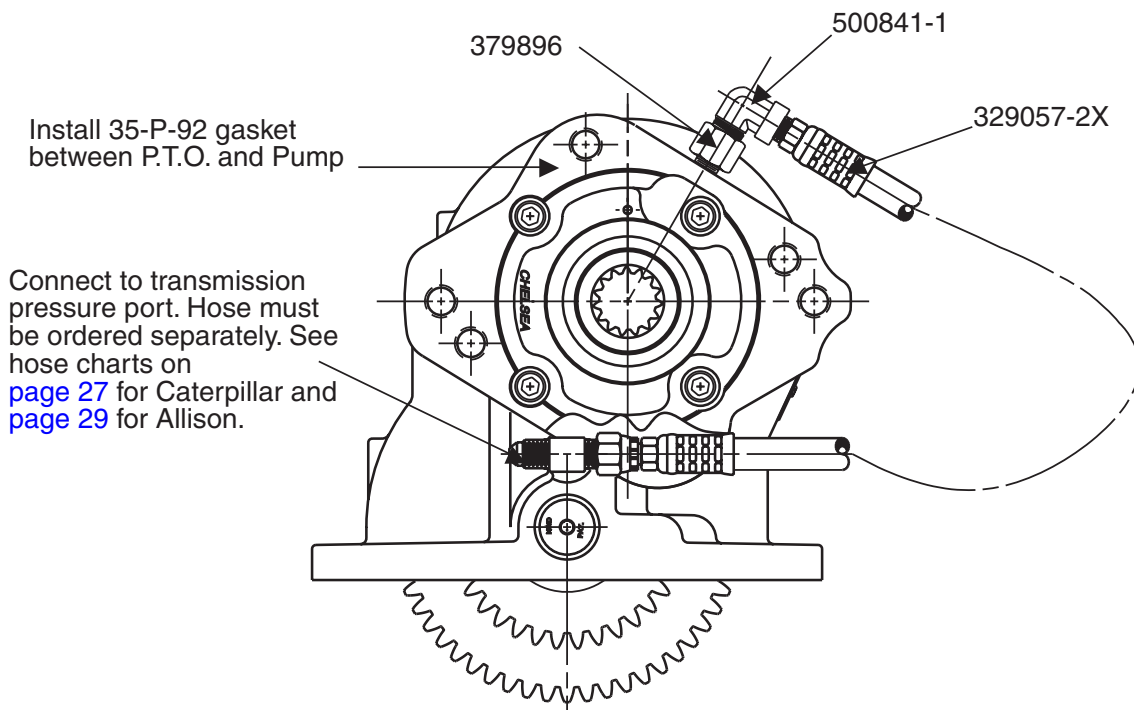

Installation "AK" Wet Spline 267 Series (SK-378 Rev A)

3 Ass'y View

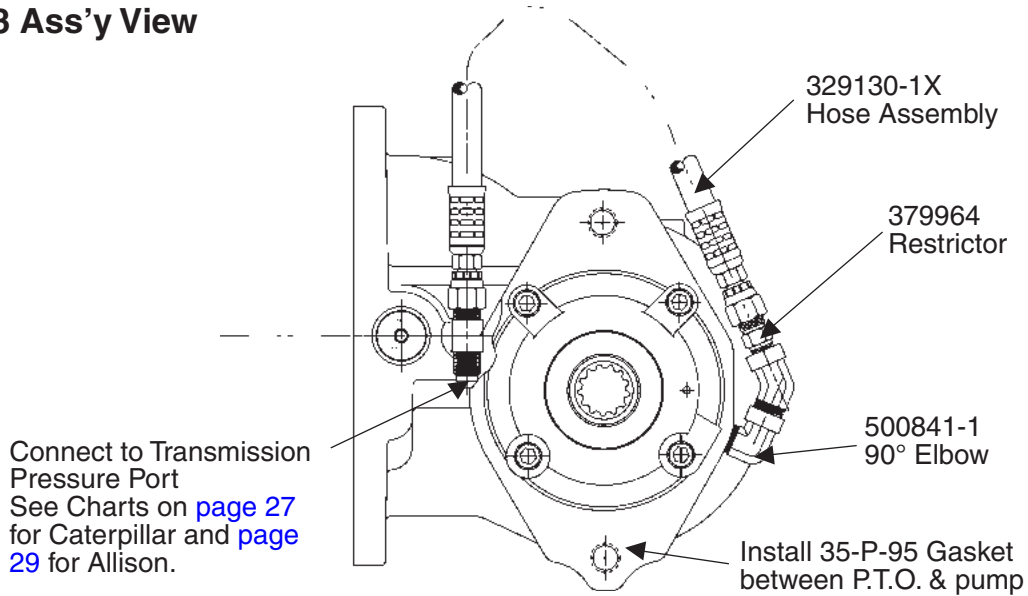

Kit #329406X for Wet Spline
 Installation Components

5 Ass'y View

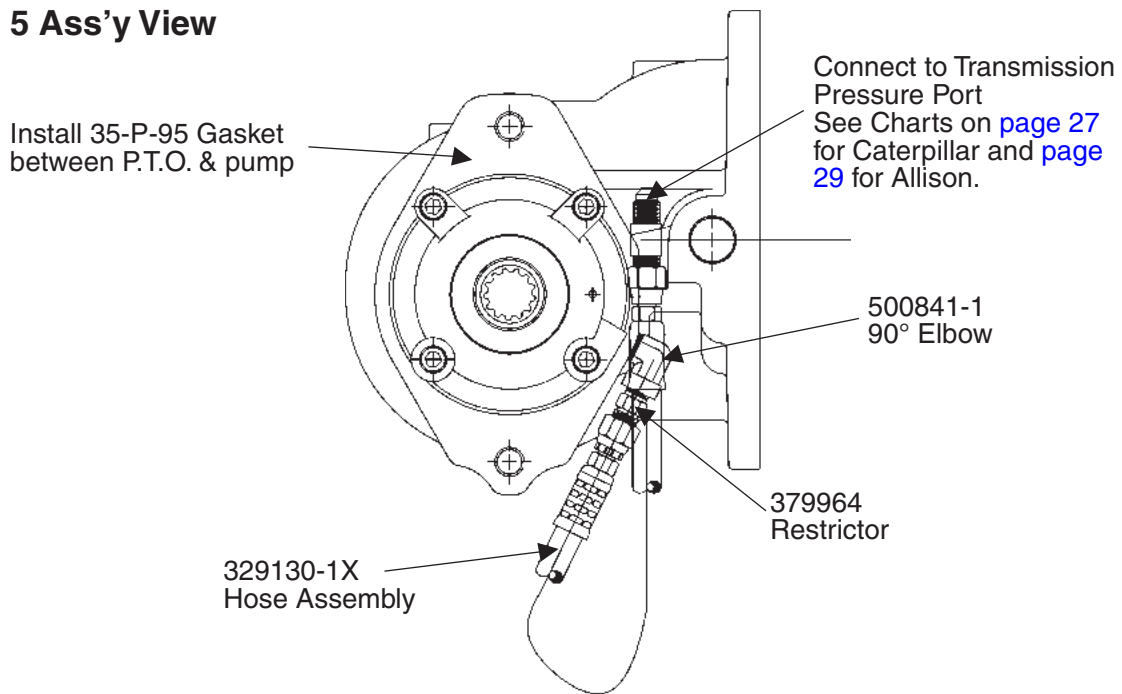

Pressure Hose Chart (Transmission to P.T.O.)		
Trans	Location	Hose
MD	Left	329130-5X
MD	Right	329130-4X
HD	Left	329130-5X
HD	Top Right	329130-8X

Installation "AF" Wet Spline 277 & 278 Series (SK-383 Rev B) (Old Style)

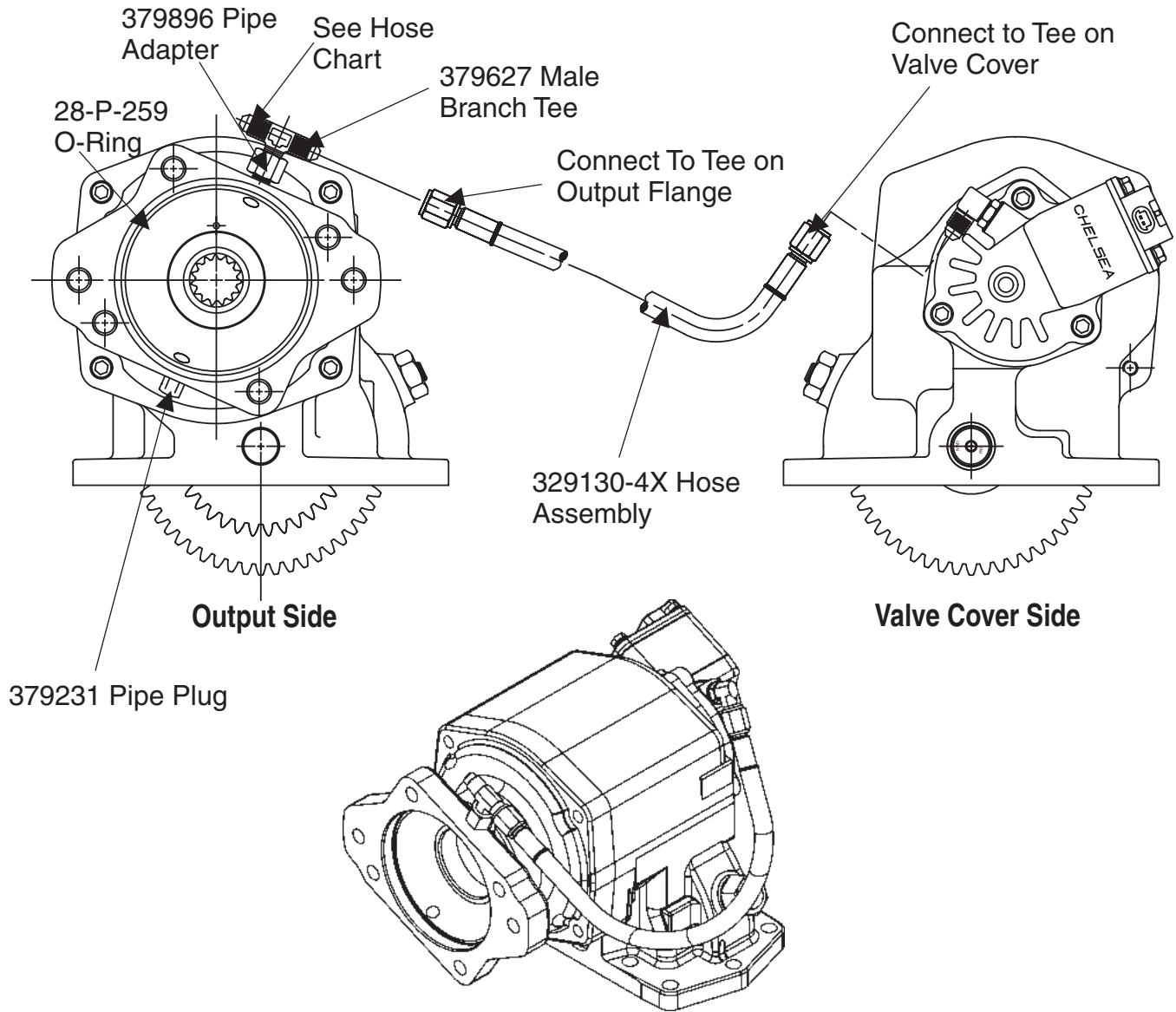

329337-6X - Wet Spline Installation Kit

Pressure Hose Chart (Transmission to P.T.O.)		
Trans	Location	Hose
MD	Left	329130-1X
MD	Right	329075-1X
HD	Left	329130-1X
HD	Right	329075-2X

Installation "AF" Wet Spline 277 & 278 Series (SK-383 Rev D) (New Style)

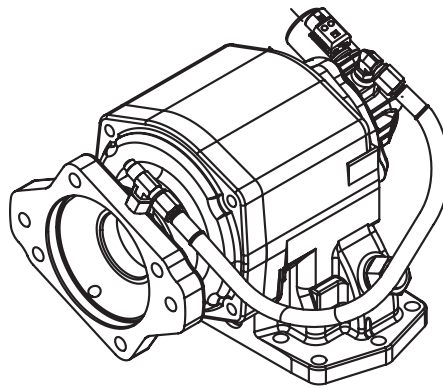
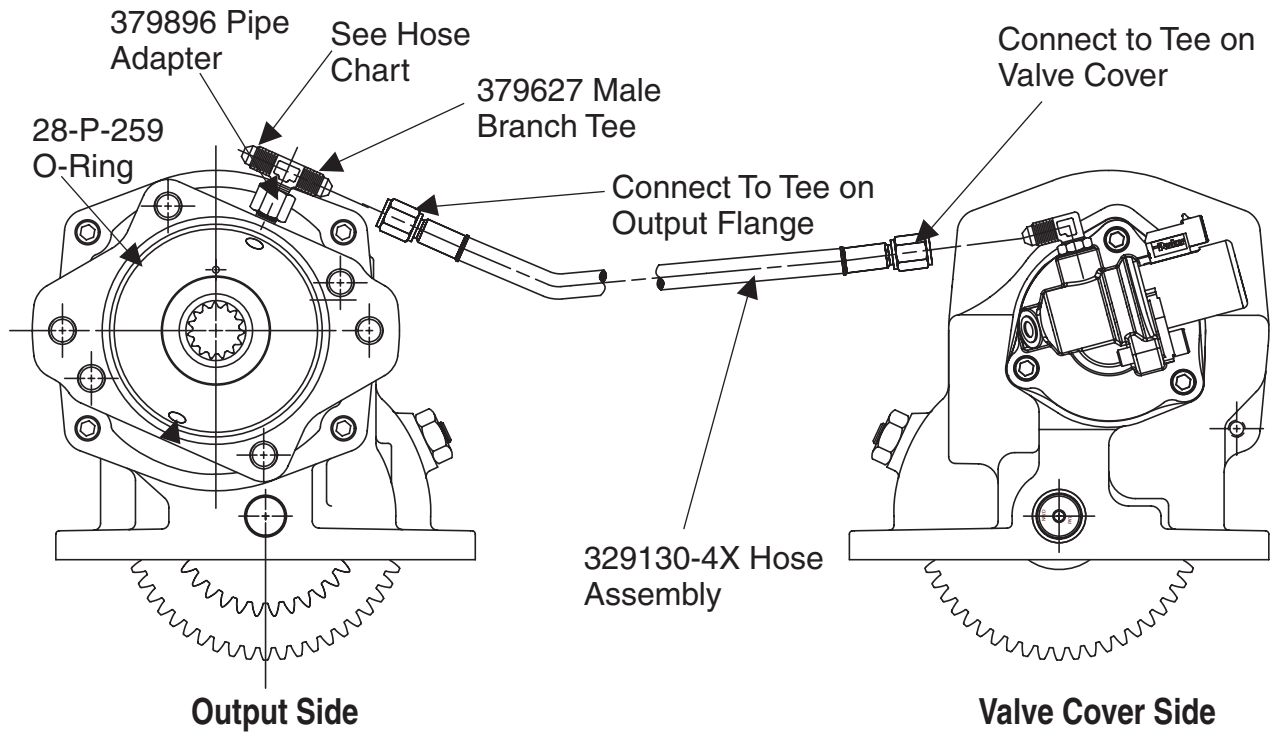

Pressure Hose Chart (Transmission to P.T.O.)		
Trans	Location	Hose
MD	Left	329130-1X
MD	Right	329075-1X
HD	Left	329130-1X
HD	Right	329075-2X

Installation "XY" Wet Spline 269 Series (SK-416 Rev B)

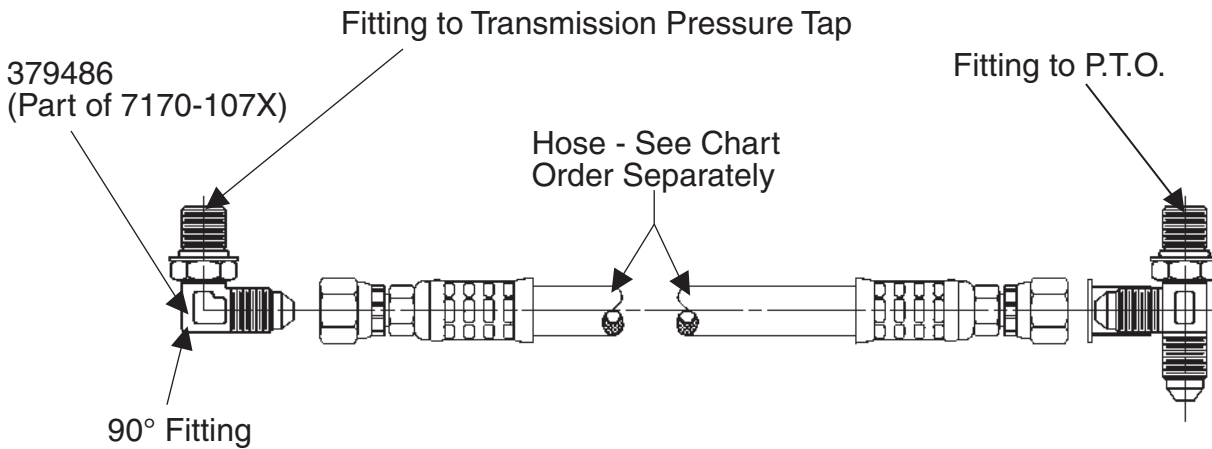
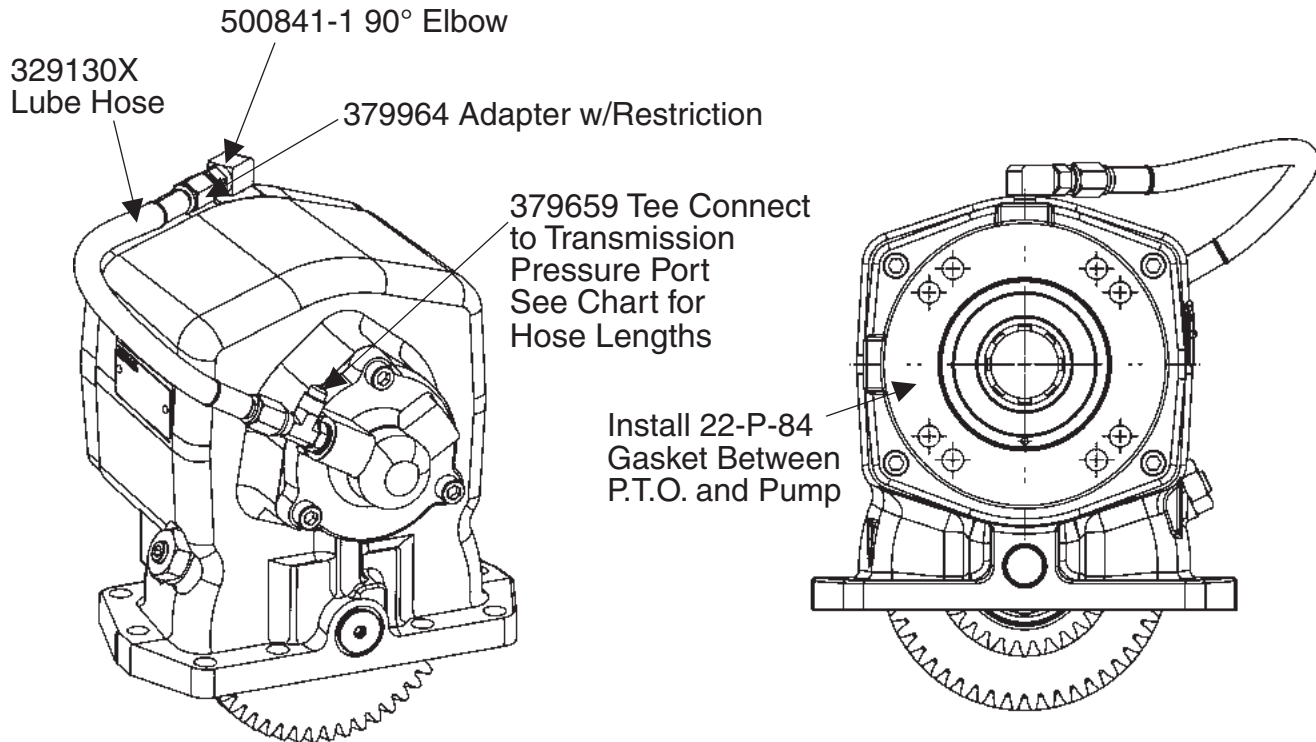

Pressure Hose Chart (Transmission to P.T.O.)		
Trans	Location	Hose
MD	Left	329130-5X
MD	Right	329075-1X
HD	Left	329075-4X
HD	Top Right	329075-2X

Installation "ZY" Wet Spline 277 & 278 Series (SK-454 Rev A)

379964 Adapter w/Restriction

500841-1 90° Elbow

379659 Tee Connect
 to Transmission
 Pressure Port
 See Chart for
 Hose Lengths

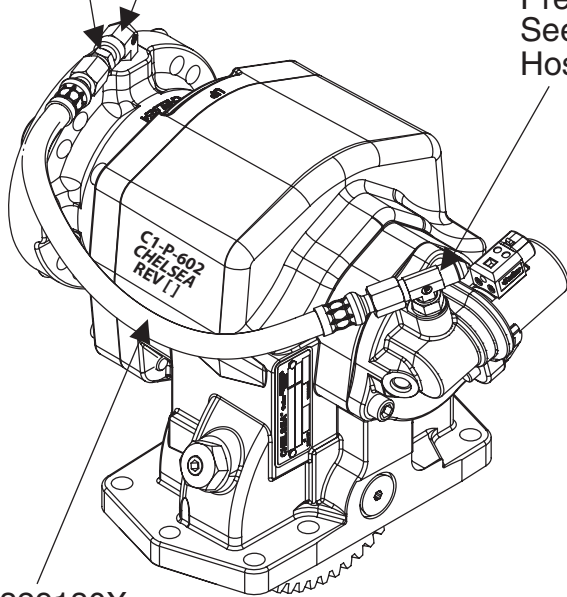

Install 22-P-84
 Gasket Between
 P.T.O. and Pump

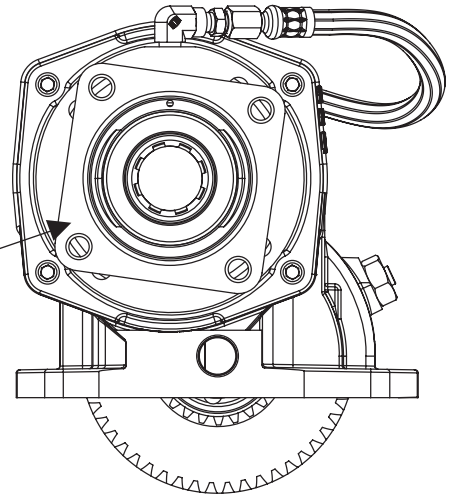

329130X
 Lube Hose

Fitting to Transmission Pressure Tap

379486
 (Part of 7170-107X)

Hose - See Chart
 Order Separately

90° Fitting

Fitting to P.T.O.

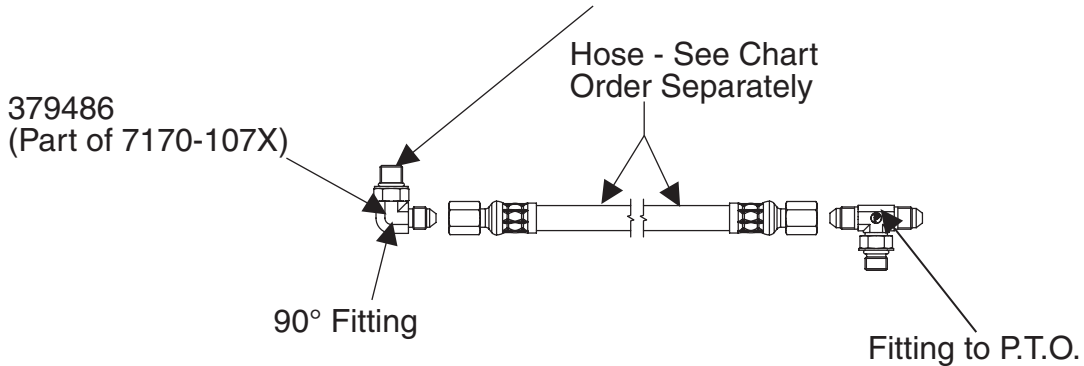

Pressure Hose Chart (Transmission to P.T.O.)		
Trans	Location	Hose
MD	Left	329130-5X
MD	Right	329075-1X
HD	Left	329075-4X
HD	Right	329075-2X

269 & 278 Series Installation Mounting Kit Instructions (SK-355 Rev B)

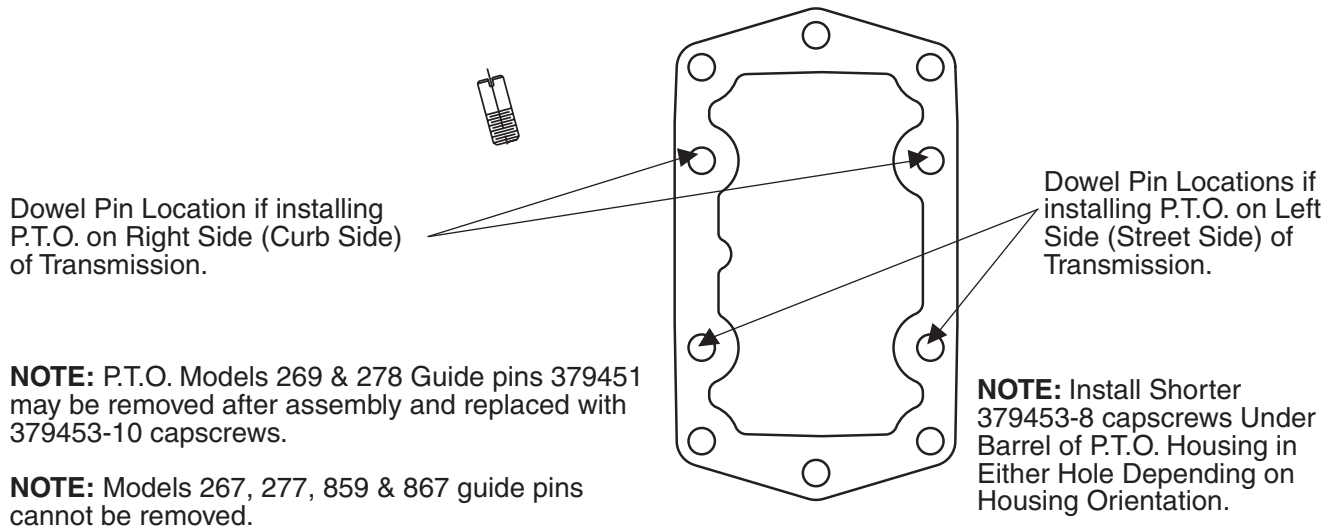

Installing Rotatable Flanges

The rotatable flange is shipped loose with the P.T.O. units for ease of installation. After determining the flange position, attach the flange to the P.T.O. bearing cap using the capscrews provided in the bag kit. Bag kit number 328170-207X (6-bolt family) will contain (3) capscrews (378447-6) and 328170-208X (277 Series) will contain (4) capscrews for attaching the flange to the P.T.O. bearing cap. After installing the capscrews make sure to torque the screws to 16-20 Lbs. ft. Consideration should be taken on the size and weight of the pump being installed. (see [pages 3 and 4](#))

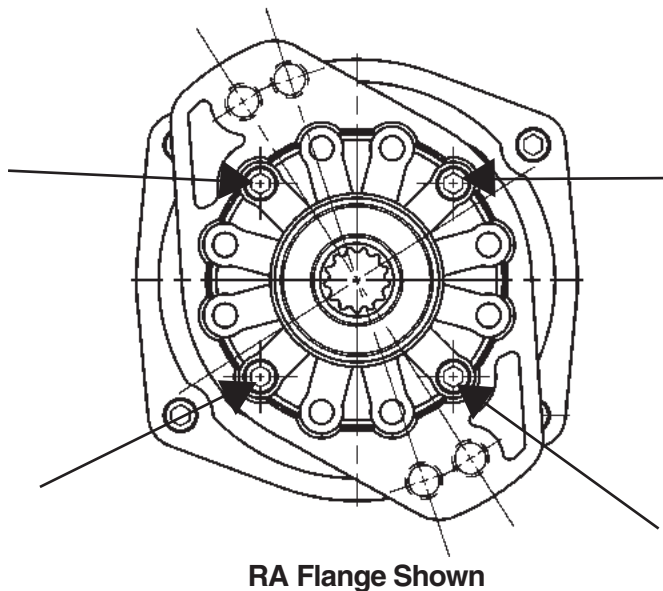

NOTE: Reinstalling or tightening of a rotatable flange after it has become loose is not recommended. If a P.T.O. has run for a length of time after the flange has become loose, the flange and / or bearing cap may not be to manufacturing tolerance.

P.T.O. Shifting Procedure & Precautions

CAUTION: This vehicle is equipped with a Power Take-Off. Shut engine off before working on the Power Take-Off or getting below the vehicle. Consult the operating instructions before using the P.T.O. (See sun visor.)

POWER TAKE-OFF OPERATION — VEHICLE STATIONARY

Automatic Transmission with Powershift P.T.O.s

Engage the P.T.O. with the engine at idle speed.

NOTE: Powershift P.T.O.s: The engine must be at idle or below 1000 R.P.M. when the P.T.O. is engaged. See the transmission manufacturer's instructions for special procedures.

IMPORTANT:

Failure to follow the proper shifting or operating sequences will result in premature P.T.O. failure with possible damage to other equipment.



Warning: Cold Weather Operation of Powershift P.T.O.s

During extreme cold weather operation [32° F (0° C) and lower], a disengaged Powershift Power Take-Off can momentarily transmit high torque that will cause unexpected output shaft rotation. This is caused by the high viscosity of the transmission oil when it is extremely cold. As slippage occurs between the Power Take-Off clutch plates, the oil will rapidly heat up and the viscous drag quickly decreases.

The Power Take-Off output shaft rotation could cause unexpected movement of the driven equipment, resulting in serious personal injury, death, or equipment damage.

To avoid personal injury or equipment damage:

- Driven equipment must have separate controls.
- Driven equipment must be left in the disengaged position when not in operation.
- Driven equipment must not be operated until the vehicle is allowed to warm up.



This symbol warns of possible personal injury.

Power Take-Off Maintenance

Due to the normal and sometime severe torsional vibrations that Power Take-Off units experience, operators should follow a set maintenance schedule for inspections. Failure to service loose bolts or Power Take-Off leaks could result in potential auxiliary Power Take-Off or transmission damage.

Periodic P.T.O. MAINTENANCE is required by the owner/operator to ensure proper, safe and trouble free operation.

Daily: Check all air, hydraulic and working mechanisms before operating P.T.O. Perform maintenance as required.

Monthly: Inspect for possible leaks and tighten all air, hydraulic and mounting hardware, if necessary. Torque all bolts, nuts, etc. to Chelsea specifications. Ensure that splines are properly lubricated, if applicable. Perform maintenance as required.

With regards to the direct mounted pump splines, the P.T.O. requires the application of a specially formulated anti-fretting, high pressure, high temperature grease. The addition of the grease has been proven to reduce the effects of the torsional vibrations, which result in fretting corrosion on the P.T.O. internal splines as well as the pump external splines. Fretting corrosion appears as a "rusting and wearing" of the pump shaft splines. Severe duty applications, which require long P.T.O. running times and high torque may require more frequent regreasing. Applications such as Utility Trucks that run continuously and are lightly loaded also require frequent regreasing due to the sheer hours of running time. It is important to note that service intervals will vary for each and every application and is the responsibility of the end user of the product. Chelsea also recommends that you consult your pump owners manuals and technical services for their maintenance guidelines. Fretting corrosion is caused by many factors and without proper maintenance; the anti-fretting grease can only reduce its effects on components.

Chelsea offers the grease to our customers in two packages. The first is a 5/8 fluid ounce tube (379688), which is included with every applicable P.T.O., and the second is a 14-ounce grease cartridge (379831). Chelsea also offers greaseable shafts for most all output designators.

Warranty: Failure to comply entirely with the provisions set forth in the appropriate Owner's Manual will result in voiding of ALL Warranty consideration.

Offer of Sale

The items described in this document and other documents or descriptions provided by Parker Hannifin Corporation, its subsidiaries and its authorized distributors are hereby offered for sale at prices to be established by Parker Hannifin Corporation, its subsidiaries and its authorized distributors. This offer and its acceptance by any customer ("Buyer") shall be governed by all of the following Terms and Conditions. Buyer's order for any such items, when communicated to Parker Hannifin Corporation, its subsidiary or an authorized distributor ("Seller") verbally or in writing, shall constitute acceptance of this offer.

1. Terms and Conditions of Sale: All descriptions, quotations, proposals, offers, acknowledgments, acceptances and sales of Seller's products are subject to and shall be governed exclusively by the terms and conditions stated herein. Buyer's acceptance of any offer to sell is limited to these terms and conditions. Any terms or conditions in addition to, or inconsistent with those stated herein, proposed by Buyer in any acceptance of an offer by Seller, are hereby objected to. No such additional, different or inconsistent terms and conditions shall become part of the contract between Buyer and Seller unless expressly accepted in writing by Seller. Seller's acceptance of any offer to purchase by Buyer is expressly conditional upon Buyer's assent to all the terms and conditions stated herein, including any terms in addition to, or inconsistent with those contained in Buyer's offer. Acceptance of Seller's products shall in all events constitute such assent.

2. Payment: Payment shall be made by Buyer net 30 days from the date of delivery of the items purchased hereunder. Amounts not timely paid shall bear interest at the maximum rate permitted by law for each month or portion thereof that the Buyer is late in making payment. Any claims by Buyer for omissions or shortages in a shipment shall be waived unless Seller receives notice thereof within 30 days after Buyer's receipt of the shipment.

3. Delivery: Unless otherwise provided on the face hereof, delivery shall be made F.O.B. Seller's plant. Regardless of the method of delivery, however, risk of loss shall pass to Buyer upon Seller's delivery to a carrier. Any delivery dates shown are approximate only and Seller shall have no liability for any delays in delivery.

4. Warranty: Seller warrants that certain Products, namely PTOs, SEMs, and Wet Line Kits sold hereunder shall be free from defects in material or workmanship for a period of twenty four months from the date of delivery to Buyer. Seller warrants that certain Products namely Pumps, and Hydraulic Accessories shall be free from defects in material or workmanship for a period of eighteen months from the date of delivery to the Buyer. The prices charged for Seller's products are based upon the exclusive limited warranty stated above, and upon the following disclaimer: **DISCLAIMER OF WARRANTY: THIS WARRANTY COMPRISES THE SOLE AND ENTIRE WARRANTY PERTAINING TO PRODUCTS PROVIDED HEREUNDER. SELLER DISCLAIMS ALL OTHER WARRANTIES, EXPRESS AND IMPLIED, INCLUDING MERCHANTABILITY AND FITNESS FOR A PARTICULAR PURPOSE.**

5. Limitation Of Remedy: SELLER'S LIABILITY ARISING FROM OR IN ANYWAY CONNECTED WITH THE ITEMS SOLD OR THIS CONTRACT SHALL BE LIMITED EXCLUSIVELY TO REPAIR OR REPLACEMENT OF THE ITEMS SOLD OR REFUND OF THE PURCHASE PRICE PAID BY BUYER, AT SELLER'S SOLE OPTION. IN NO EVENT SHALL SELLER BE LIABLE FOR ANY INCIDENTAL, CONSEQUENTIAL OR SPECIAL DAMAGES OF ANY KIND OR NATURE WHATSOEVER, INCLUDING BUT NOT LIMITED TO LOST PROFITS ARISING FROM OR IN ANYWAY CONNECTED WITH THIS AGREEMENT OR ITEMS SOLD HEREUNDER, WHETHER ALLEGED TO ARISE FROM BREACH OF CONTRACT, EXPRESS OR IMPLIED WARRANTY, OR IN TORT, INCLUDING WITHOUT LIMITATION, NEGLIGENCE, FAILURE TO WARN OR STRICT LIABILITY.

6. Changes, Reschedules and Cancellations: Buyer may request to modify the designs or specifications for the items sold hereunder as well as the quantities and delivery dates thereof, or may request to cancel all or part of this order, however, no such requested modification or cancellation shall become part of the contract between Buyer and Seller unless accepted by Seller in a written amendment to this Agreement. Acceptance of any such requested modification or cancellation shall be at Seller's discretion, and shall be upon such terms and conditions as Seller may require.

7. Special Tooling: A tooling charge may be imposed for any special tooling, including without limitation, dies, fixtures, molds and patterns, acquired to manufacture items sold pursuant to this contract. Such special tooling shall be and remain Seller's property notwithstanding payment of any charges by Buyer. In no event will Buyer acquire any interest in apparatus belonging to Seller which is utilized in the manufacture of the items sold hereunder, even if such apparatus has been specially converted or adapted for such manufacture and notwithstanding any charges paid by Buyer. Unless otherwise agreed, Seller shall have the right to alter, discard or otherwise dispose of any special tooling or other property in its sole discretion at any time.

8. Buyer's Property: Any designs, tools, patterns, materials, drawings, confidential information or equipment furnished by Buyer or any other items which become Buyer's property, may be considered obsolete and may be destroyed by Seller after two (2) consecutive years have elapsed without Buyer placing an order for the items which are manufactured using such property, Seller shall not be responsible for any loss or damage to such property while it is in Seller's possession or control.

9. Taxes: Unless otherwise indicated on the face hereof, all prices and charges are exclusive of excise, sales, use, property, occupational or like taxes which may be imposed by any taxing authority upon the manufacture, sale or delivery of the items sold hereunder. If any such taxes must be paid by Seller or if Seller is liable for the collection of such tax, the amount thereof shall be in addition to the amounts for the items sold. Buyer agrees to pay all such taxes or to reimburse Seller therefore upon receipt of its invoice. If Buyer claims exemption from any sales, use or other tax imposed by any taxing authority, Buyer shall save Seller harmless from and against any such tax, together with any interest or penalties thereon which may be assessed if the items are held to be taxable.

10. Indemnity For Infringement of Intellectual Property Rights: Seller shall have no liability for infringement of any patents, trademarks, copyrights, trade dress, trade secrets or similar rights except as provided in this Part 10. Seller will defend and indemnify Buyer against allegations of infringement of U.S. Patents, U.S. Trademarks, copyrights, trade dress and trade secrets (hereinafter 'Intellectual Property Rights'). Seller will defend at its expense and will pay the cost of any settlement or damages awarded in an action brought against Buyer based on an allegation that an item sold pursuant to this contract infringes the Intellectual Property Rights of a third party. Seller's obligation to defend and indemnify Buyer is contingent on Buyer notifying Seller within ten (10) days after Buyer becomes aware of such allegations of infringement, and Seller having sole control over the defense of any allegations or actions including all negotiations for settlement or compromise. If an item sold hereunder is subject to a claim that it infringes the Intellectual Property Rights of a third party, Seller may, at its sole expense and option, procure for Buyer the right to continue using said item, replace or modify said item so as to make it noninfringing, or offer to accept return of said item and return the purchase price less a reasonable allowance for depreciation. Notwithstanding the foregoing, Seller shall have no liability for claims of infringement based on information provided by Buyer, or directed to items delivered hereunder for which the designs are specified in whole or part by Buyer, or infringements resulting from the modification, combination or use in a system of any item sold hereunder. The foregoing provisions of this Part 10 shall constitute Seller's sole and exclusive liability and Buyer's sole and exclusive remedy for infringement of Intellectual Property Rights.

If a claim is based on information provided by Buyer or if the design for an item delivered hereunder is specified in whole or in part by Buyer, Buyer shall defend and indemnify Seller for all costs, expenses or judgments resulting from any claim that such item infringes any patent, trademark, copyright, trade dress, trade secret or any similar right.

11. Force Majeure: Seller does not assume the risk of and shall not be liable for delay or failure to perform any of Seller's obligations by reason of circumstances beyond the reasonable control of Seller (hereinafter 'Events of Force Majeure'). Events of Force Majeure shall include without limitation, accidents, acts of God, strikes or labor disputes, acts, laws, rules or regulations of any government or government agency, fires, floods, delays or failures in delivery of carriers or suppliers, shortages of materials and any other cause beyond Seller's control.

12. Entire Agreement/Governing Law: The terms and conditions set forth herein, together with any amendments, modifications and any different terms or conditions expressly accepted by Seller in writing, shall constitute the entire Agreement concerning the items sold, and there are no oral or other representations or agreements which pertain thereto. This Agreement shall be governed in all respects by the law of the State of Ohio. No actions arising out of the sale of the items sold hereunder or this Agreement may be brought by either party more than two (2) years after the cause of action accrues.

10/09-P



Parker Hannifin Corporation
Chelsea Products Division
8225 Hacks Cross Road
Olive Branch, Mississippi 38654 USA
Tel: (662) 895-1011
Fax: (662) 890-5379
www.parker.com/chelsea

FP 03/10 4.5M