

Compressor Section



811 W. Rose, Walla Walla, WA 99362
Phone: (509)525-5070 Fax: (509)525-3753 1-800-541-8910
www.heco.net | E-mail: heco@bmi.net

(Editor's note: The following article was prepared by the IMACA staff using background materials from a variety of sources.)

HOW AIR CONDITIONERS REMOVE HEAT

It isn't necessary to understand how an air conditioner works to appreciate the results it produces. Nor is it necessary to understand the principles of air conditioning to perform basic air conditioner service jobs.

When the mechanic graduates to the kind of more difficult jobs reserved for the true professional, however, a thorough understanding of what is happening inside the system becomes absolutely essential.

THE BASIC MISCONCEPTION

Perhaps the most common misconception surrounding the air conditioner is that it in some way manufactures cold air.

Technically speaking, that is impossible. Cold doesn't exist. It is simply a term that was invented to describe low levels of heat.

Heat, on the other hand, is something more than a concept. It is a form of energy that is present to a greater or lesser extent in every known substance.

An air conditioner deals with heat. Its job is to remove unwanted heat from the air in one location and put that heat somewhere else.

In the case of a car or a truck that means removing excess heat from the passenger compartment and discharging it into the outside air.

MEASURING HEAT

Heat is measured in two ways. The first and most basic unit of measurement is the British Thermal Unit (BTU). It is the amount of heat required to change the temperature of one pound of water one degree Fahrenheit. BTUs are used to measure the total amount of heat in an object.

Temperature is the other way of measuring heat. It is a kind

of a spot reading that tells how much heat is concentrated in a given area.

Five thousand BTUs of heat in a small room would produce a higher temperature reading than the same 5,000 BTUs of heat in a large room since the BTUs in the larger room would be spread over a greater area.

From the air conditioning specialist's standpoint both forms of measurement are useful.

Air conditioners used in buildings are normally rated in terms of the number of BTUs of heat they can remove per hour. The typical automotive air conditioner falls in the 18,000 BTU/hour range using that system.

Temperature provides a way of measuring the results of the work that an air conditioner is doing.

HEAT MOVEMENT

Air conditioning is made possible by the fact that heat is always moving from objects that have more heat to those that have less. In case of the automotive air conditioner, the evaporator in the passenger compartment serves as the low temperature object that draws heat from the air trapped inside the vehicle.

Heat moves by conduction, convection, and radiation. All three ways relate directly to automotive air conditioning and the way it works.

CONDUCTION

In conduction heat actually flows from one molecule of a substance to another molecule of the same substance or of a different substance.

When conduction takes place in an air conditioner it takes the form of heat being passed from molecules of air to molecules of evaporator tubing and then to molecules of refrigerant inside the tubing. Instead, it deposits its heat in the tubing. The air doesn't actually pass through the tubing it touches and the tubing deposits the same heat in the refrigerant.

CONVECTION

Convection is a form of heat movement that occurs in fluids (air is technically a fluid). In convection heat is transported from one location to another inside moving molecules. The flow of cool air from an air conditioner is an example of convection. A stream of cool air can actually be detected flowing from the duct, usually with the help of a fan to push it along.

RADIATION

Radiation is another form of heat movement. It is an example of energy in motion. When radiation occurs heat will pass from one location to another without depending on molecules for a free ride. Heat radiates from the Sun to Earth through the vacuum of space. Heat also radiates through the roof and windshield of a car which explains why it can be hotter inside a closed vehicle than outside on a sunny day. The heat moves inside more quickly by radiation than it can be passed outside to the cooler air by conduction through the glass and sheet metal.

HEAT FLOW

Although heat is constantly flowing from objects that have more heat to those that have less, the speed at which heat transfer takes place can vary.

One factor is temperature difference. The greater the difference in the temperature the more quickly heat will move from the warmer substance to the cooler. For maximum cooling the air conditioner evaporator should be kept as low as possible. The practical limit is about 32 degrees Fahrenheit. At lower temperatures ice begins to form on the outside of the evaporator and the heat transfer process is slowed down.

The effect of ice on the efficiency of an air conditioner is an example of another factor influencing heat transfer; that heat passes through some substances more quickly than it passes through others. By way of comparison the aluminum used in evaporator coils and fins is a good conductor of heat while ice is a good insulator.

Surface area is a third factor influencing heat transfer. The greater the surface area of two substances of different temperatures, the more quickly heat transfer will take place. Air conditioner evaporator (and condenser) fins increase surface area.

SOLID, LIQUID, OR VAPOR

In addition to taking advantage of the characteristics of heat flow, the air conditioner also takes advantage of the fact that tremendous quantities of heat are absorbed or given up when substances change form. In going from solid to liquid to vapor substances absorb heat. In moving from vapor to liquid to solid they give up heat. Since solids won't flow through the system, an air conditioner deals with refrigerant in liquid and vapor form.

Refrigerant enters an evaporator as a liquid and it absorbs the large quantities of heat required to turn it into a vapor as it passes through the coils and leaves the evaporator.

THE BOILING POINT

The temperature at which a substance goes from being a liquid to being a vapor is its boiling point. That temperature varies with different substances.

To pull a great deal of heat out of the air at the kind of temperatures recorded in a vehicle, the refrigerant used must have a very low boiling point. In the case of the most commonly used automotive refrigerant, R-12 (Dupont Freon is the most recognized brand name), the boiling point at sea level is minus 27 degrees Fahrenheit compared to plus 212 degrees Fahrenheit for water. When it is released into the air R-12 will vaporize instantly, absorbing a lot of heat as it does.

THE EFFECT OF PRESSURE

The boiling point of R-12 under atmospheric conditions is so low as to make it of little practical value. The boiling point of a substance, however, can be raised by increasing the pressure of it. Internal air conditioner pressure provides a way of controlling the temperature at which the refrigerant will go from liquid to vapor and then back to liquid again. If the pressure in the line that carries refrigerant to the evaporator is high enough to keep the refrigerant in liquid form and the pressure in the evaporator itself is low, the refrigerant will vaporize as it passes through the evaporator and it will absorb a great deal of heat in the process.

The refrigerant is drawn out of the evaporator in the form of a relatively low pressure vapor by compressor. The action of the compressor then turns the low pressure vapor into a high pressure vapor which the compressor pushes to the condenser where the process is reversed. In the condenser the high pressure vapor, which is thoroughly saturated with heat, gives up that heat and the heat is transferred to the outside air. The refrigerant goes back into a liquid as it gives up heat and it is returned to the evaporator as a high pressure liquid to repeat the cycle.

The process only works, however, when the compressor is running. When the compressor not pulling low pressure vapor out of the evaporator and turning it into high pressure vapor as it pushes it along into the condenser, the temperatures and pressures throughout the system tend to equalize and the heat transfer process comes to a stop.

THE AIR CONDITIONER AS A DEHUMIDIFIER

The human body cools itself using the same process of evaporation that makes it possible for an air conditioner to function. In the case of humans, fluids reach the outside air through the skin where they evaporate removing excess heat in the process.

The major difference between the human cooling system and air conditioners is that humans don't have a refrigerant recovery system. Their fluids simply evaporate into the air and must be replaced in the form of new fluids being taken in.

The human cooling system is most efficient when the surrounding air is cool enough to easily absorb excess body heat and when the level of moisture in the air (humidity) is low enough to make it possible for the air to readily accept the moisture being given up by the body.

The air conditioner creates a comfortable environment by removing both high levels of heat and moisture from the air.

The removal of moisture is a by-product of heat removal. The amount of moisture that air can hold varies with the temperature of the air. Warm air will hold more moisture than cool air.

As the air conditioner removes heat from the air it reduces the air's capacity to hold moisture. When the conditions are right (high humidity, big temperature drop) moisture will condense out of the air and collect on any nearby cool surface, either the evaporator or the duct work in the case of an auto air conditioner. Thus, returning air that is both cooler and drier to the passenger area. The amounts of water involved make it necessary for the air conditioner to be equipped with a drain system to remove the moisture that is collected.

That removal of moisture from the air along with heat makes it possible for the air conditioner to produce a comfortable passenger environment at higher temperatures than if heat only were removed. The lower moisture level makes it easier for the human body to cool itself.

The normal human comfort range is 72 to 80 degrees Fahrenheit at 40-50% humidity. If the humidity is decreased, an increase in temperature is permissible and correspondingly, if the humidity increases a lower temperature is required to create the kind of conditions that promote efficient body cooling.

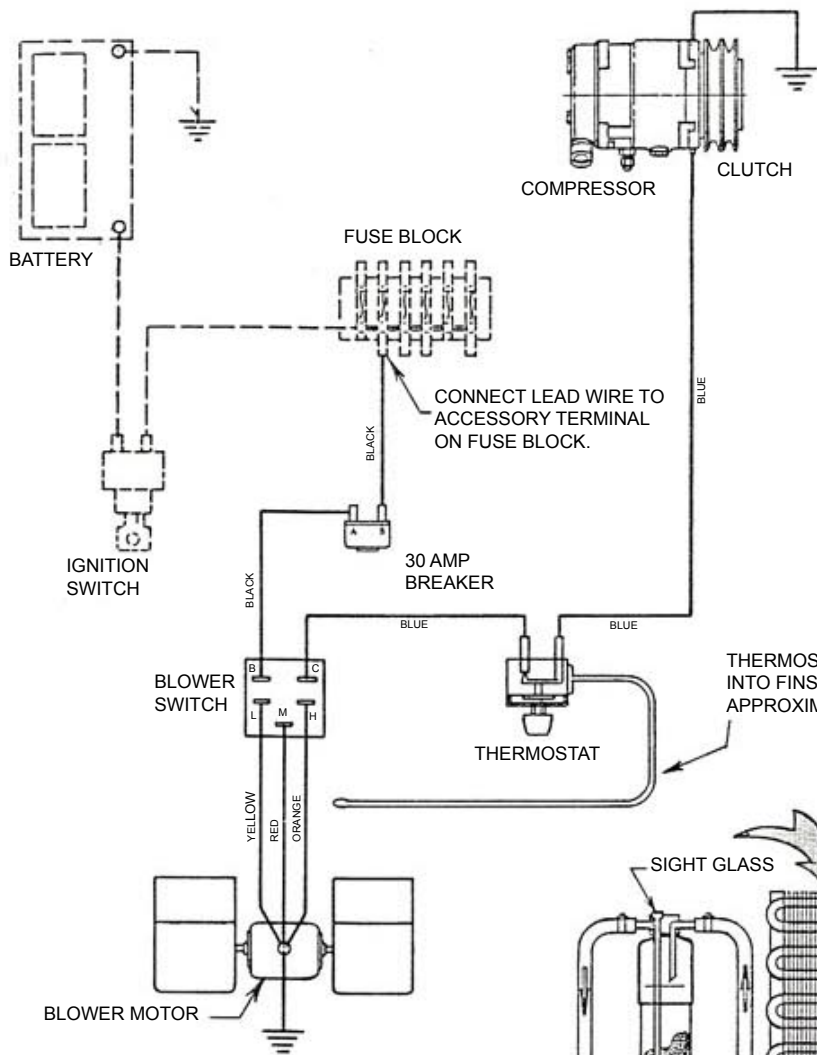

◀ **WIRING DIAGRAM**

AUTO AIR CONDITIONING REFRIGERANT CYCLE ▶

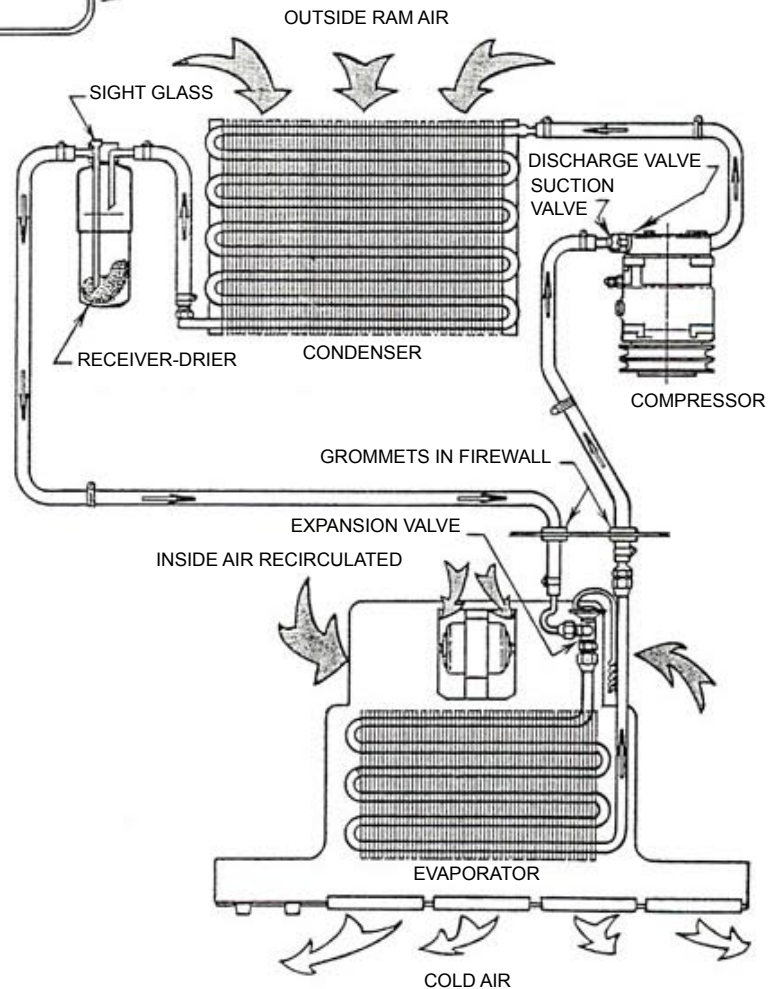

AIR CONDITIONING PERFORMANCE FACTS

Each air conditioning system should be balanced between the compressor, condenser and the evaporator to achieve the performance desired on each application.

The capability of the compressor will determine the performance and not the size and BTU rating of the evaporator and condenser listed.

This is especially important when choosing an air conditioning system for truck, buses and larger vehicles.

Compressor Performance Averages At 240 PSI Discharge

Compressor		RPM	BTU	Maximum BTU At 4000 RPM
Sanden 508	AT	3000 RPM	28,000 BTU	33,500 BTU
Sanden 508	AT	2000 RPM	21,000 BTU	
Sanden 709	AT	3000 RPM	30,500 BTU	36,600 BTU
Sanden 709	AT	2000 RPM	24,500 BTU	
Sanden 510	AT	3000 RPM	32,000 BTU	38,400 BTU
Sanden 510	AT	2000 RPM	24,000 BTU	
Diesel Kiki 15CH	AT	3000 RPM	30,000 BTU	36,000 BTU
Diesel Kiki 15CH	AT	2000 RPM	21,500 BTU	
DKS 26 Diesel Kiki	AT	3000 RPM	38,000 BTU	45,500 BTU
DKS 26 Diesel Kiki	AT	2000 RPM	32,000 BTU	
Delco A6	AT	3000 RPM	35,000 BTU	42,000 BTU
Delco A6	AT	2000 RPM	27,000 BTU	
Climate Control (York) 210	AT	3000 RPM	30,000 BTU	36,000 BTU
	AT	2000 RPM	22,000 BTU	
Bock FK3	AT	3000 RPM	75,000 BTU	3000 RPM Maximum recommended speed
Bock FK3	AT	2000 RPM	60,000 BTU	
Bock FK4	AT	3000 RPM	150,000 BTU	
Bock FK4	AT	2000 RPM	123,000 BTU	

Delphi Compressor

Part No.	Volt	Type	Clutch Dia.	Clutch Grooves	Grove Width	Oil
CO08810	12	Delphi SP10	4 3/4"	2	1/2"	
Used on Landini's and Massey Ferguson						

Ford Compressor



Part No.	Volt	Type	Clutch Dia.	Clutch Grooves	Grove Width	Oil
CO01262	12	FS10	4 7/8"	6	Serpentine	6 oz

IDENTIFICATION

GM A-6 COMPRESSOR

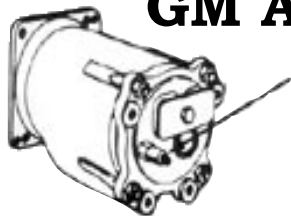

High Pressure
Relief Valve

High Pressure
Switch

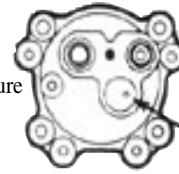

NOTE POSITION
AND DIAMETER
OF HOLE

Superheat
Switch

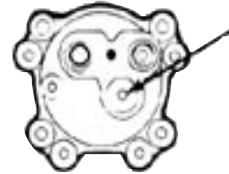

No High Pressure
Valve Port
No Switch



04005



04016

WARNING: Do not interchange superheat and high pressure switch type compressors. Compressor and or clutch damage will result.

IMPORTANT! WHEN REPLACING COMPRESSORS:

1. Replace Accumulator or Filter-Drier.
2. Check Expansion Valve--Replace if contaminated.
3. Flush System
4. Check Oil

DOES NOT INCLUDE SUPER HEAT OR HIGH SIDE PRESSURE SWITCH

REMFG. PART NO.	SWITCH TYPE	DUST COVER	VOLT	COIL LOCATION	CLUTCH DIAMETER
04005	SHS	YES	12V	10:00	5 5/8"
04006	SHS	YES	24V	2:00	5 5/8"
04008	NONE	YES	12V	10:00	6 3/4"
04009	SHS	YES	12V	2:00	5 5/8"
04016	NONE	YES	24V	2:00	6 3/4"
04017	SHS	YES	24V	10:00	6 3/4"
04018	NONE	YES	12V	10:00	6 3/4"
04019	HSPS	YES	12V	2:00	5 5/8"
04020	HSPS	YES	12V	10:00	6 3/4"

HSPS - HIGH SIDE PRESSURE SWITCH
SHS - SUPERHEAT SWITCH

Superheat Switch # 25938
High Pressure Switch # 25939
High Pressure Relief Valve # 650-665

1. COIL LOCATION IS FROM CLUTCH END
2. ALL THESE GM A-6 COMPRESSORS TURN CW FACING CLUTCH END
3. Suction port is the one with screen in it.

Thermal Fuse Part No. 25779

Wiring Harness for Thermal Fuse Part No. 04261

GM A-6 COMPRESSOR

OIL CHECK PROCEDURES

The oil level can be checked with compressor installed in system or with compressor removed. The preferred method is to purge all old oil and fill with recommended quantity of oil and refrigerant.

To check oil level of installed compressor, operate air conditioner system for 10 minutes with controls set for maximum cooling and high blower speed. Engine should be running at about 2000 rpm. Stop engine and momentarily crack compressor drain plug (see picture below) to let a small amount of oil blow out, then tighten plug. Loosen drain plug slightly for the second time, check for oil, then tighten plug. If oil appears the second time, the compressor has an adequate supply of oil. Foamy oil is considered normal. Absence of oil at second check indicates low oil level. Installation is usually accomplished with compressor stopped. Be careful not to overfill system. Check refrigerant pressures after servicing with oil. Oil level can also be bench checked as described in the following paragraphs.

To bench check oil level of operating compressor, operate air conditioner for 10 minutes with controls set for maximum cooling and high blower speed. Engine should be running at 1500 rpm. Stop engine, discharge system, then remove compressor. Position compressor horizontal with drain plug downward, remove drain plug and allow all oil to drain from compressor into clean container. Measure the amount of oil removed, then discard old oil. If more than four fluid ounces (118 mL) of old oil was drained from compressor, install same amount of new 525 viscosity oil as was drained. If less than four fluid ounces (118 mL) of old oil was drained, add six fluid ounces (177 mL) of Delco #15-117 or equivalent oil, then install drain plug. If oil that was drained contained chips, moisture or other foreign material, flush system, install new receiver-drier, evacuate system, install correct total amount (about 11 fluid ounces or 325 mL) of oil, then recharge system with refrigerant. Be sure to add additional oil if new receiver-drier, evaporator, condenser, etc., is installed. Oil capacity of the entire system is about 11 fluid ounces (325 mL).

To bench check oil level of compressor that is not operational (or not installed), remove compressor and drain old oil into clean container. Check quantity and quality of drained oil. The compressor should contain six fluid ounces (177 mL) of oil; however, be sure to add additional oil if other new (dry) components are installed or if system is flushed (sweep-charged). The receiver-drier contains one fluid ounce (30 mL) of oil, the evaporator about three fluid ounces (89 mL) and the condenser about one fluid ounce (30 mL). Additional oil will also coat inside of hoses, etc. Total capacity will be approximately 11 fluid ounces (325 mL). If old oil that was drained from compressor is contaminated with metal particles, moisture or other foreign material, flush system, install new receiver-drier, evacuate system, install correct total amount of oil, then recharge system with refrigerant.

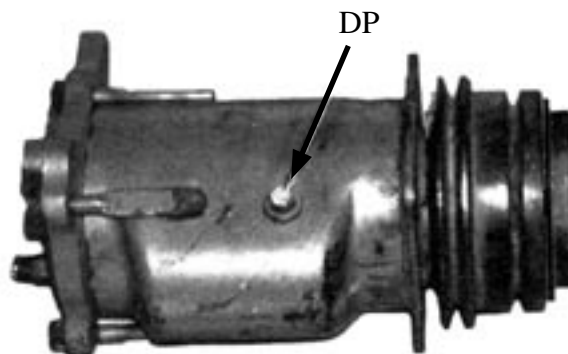

Drain plug (DP) for Delco-Air compressor is used to remove lubricating oil from compressor

SANDEN COMPRESSORS



(9120)
(9674)

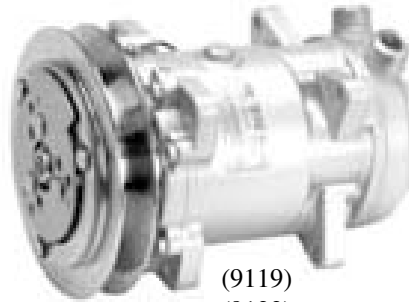

(9119)
(9122)
(9675)
(9676)



(7409)
(4627)
(4652)



(9026)
(4513)
(7819)
(9125)



(9120)(4510)
(9515)(4506)
(5407)(9103)



(9537)

(8387) (8399)



(9514)



(9592)



(4511)
(5425)
(4515)
(4516)

IMPORTANT: To insure protection of the system ALWAYS install a Filter Drier/Accumulator and Expansion Valve/Orifice Tube when replacing the compressor.

SANDEN COMPRESSORS

SD508

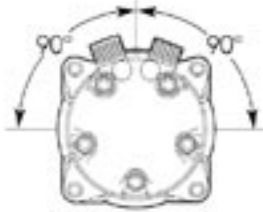

SD508 AND SD510-HD MOUNTING

Mounting options up to 90° from vertical.

SD510-HD

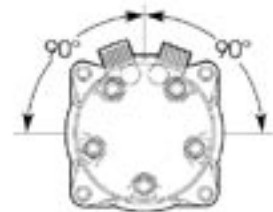

SD508 DIMENSIONS AND PHYSICAL DATA SD-508

Dimensions shown in millimeters

COMPRESSOR SPECIFICATIONS:

Bore	1.378 in.	35mm
Stroke	1.13 in.	28.6mm
Displacement Per Revolution	8.42 cu. in.	138cc
Number of Cylinders	5	
Maximum Allowable Continuous R.P.M. (Normal Operating Conditions)	5,000	
Refrigerant	R-12	
Oil (SUNISO 5GS or Equivalent)	7 Fl. Oz.	207cc
Weight	11.24 lb.	5.1 kg.
Rotation	Clockwise or Counterclockwise	

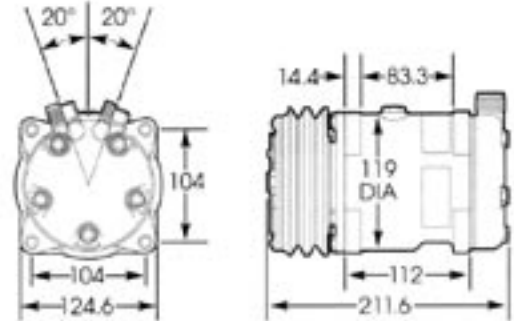

Dimensions shown in millimeters

SD510 DIMENSIONS AND PHYSICAL DATA SD-510-HD

COMPRESSOR SPECIFICATIONS:

Bore	1.417 in.	36mm
Stroke	1.13 in.	31.7mm
Displacement Per Revolution	9.825 cu. in.	161cc
Number of Cylinders	5	
Maximum Allowable Continuous R.P.M. (Normal Operating Conditions)	4,000	
Refrigerant	R-12	
Oil (SUNISO 5GS or Equivalent)	4.6 Fl. Oz.	135cc
Weight	10.36 lb.	4.9 kg.
Rotation	Clockwise Facing Clutch End	

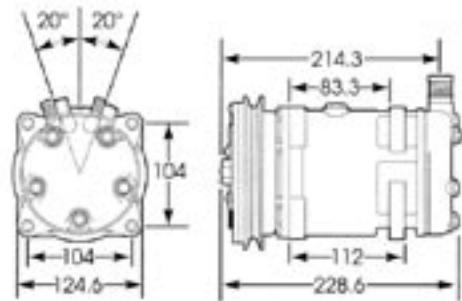

SD709 DIMENSIONS AND PHYSICAL DATA

COMPRESSOR SPECIFICATIONS:

Bore	1.153 in.	29.3mm
Stroke	1.29 in.	32.8mm
Displacement Per Revolution	9.5 cu. in.	154.9cc
Number of Cylinders	7	
Maximum Allowable Continuous R.P.M. (Normal Operating Conditions)	6,000	
Refrigerant	R-12	
Oil (SUNISO 5GS or Equivalent)	4.6 Fl. Oz.	135cc
Weight	9.10 lb.	4.2 kg.
Rotation	Clockwise	



SANDEN COMPRESSOR SPECIFICATIONS FOR R134a

SD5H14 Compressor Series

- Refrigerant - R134a
- Refrigerant oil - Sanden SP-15 (PAG)
- Oil Charge - 175cc
- Displacement - 138cc
- Bore - 35mm
- Stroke - 28.7mm
- Weight with oil - 11.6 lbs/5.3 kgs
- Rotation - clockwise or counterclockwise
- Mounting angle - 90° left or right of center

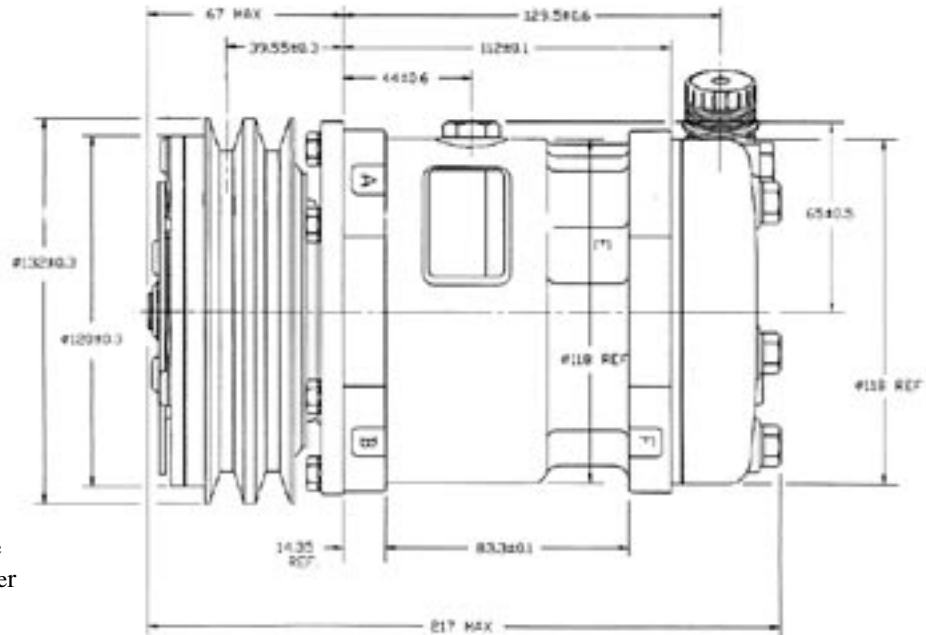

SD7H15 Compressor Series

- Refrigerant - R134a
- Refrigerant oil - Sanden SP-15 (PAG)
- Oil Charge - 150cc
- Displacement - 155cc
- Bore - 29.3mm
- Stroke - 32.8mm
- Weight with oil - 10.2 lbs/4.6 kgs
- Rotation - clockwise
- Mounting angle - 90° left or right of center

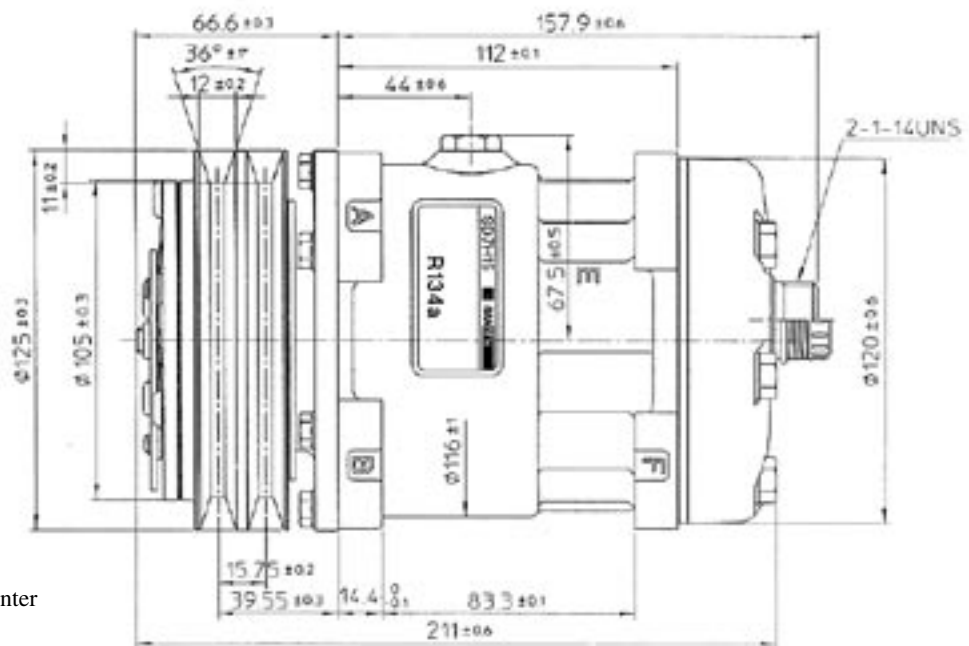

Dimensions shown in millimeters
(Millimeter dimension X.0394=inches)

SANDEN COMPRESSOR IDENTIFICATION

Manufacturing Date Codes
are stamped on the compressor.
(US Manufacture Only)

Year of Mfg. (First Digit) →
i.e. 3 indicates manufactured
in 1993

Month of Mfg. (Last Digit) →
January thru September 1-9
October = X
November = Y
December = Z

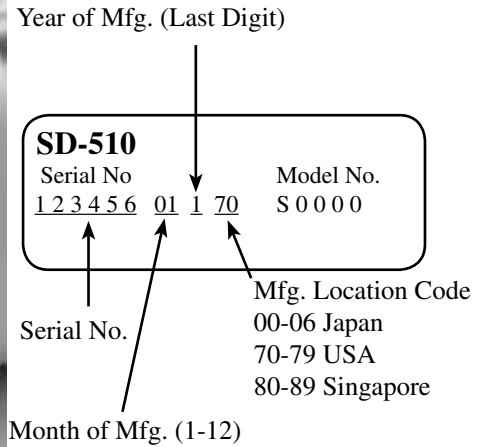
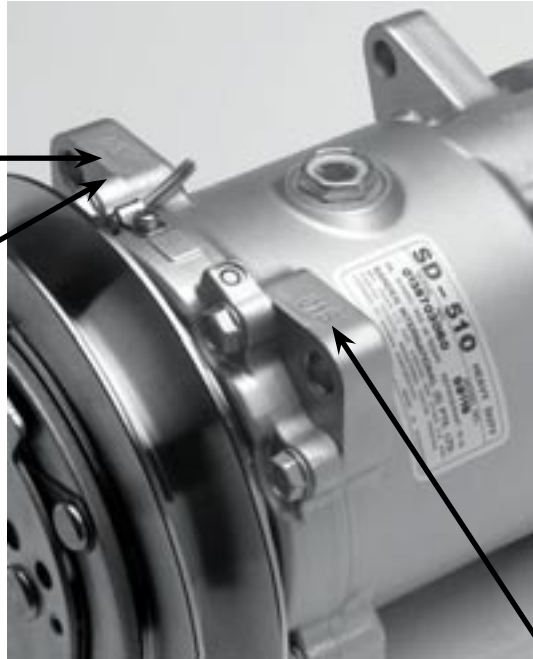

→ This is a Sanden Internal Code

The metal nameplate located at the top front of the compressor serves as a means of identification. There are numbers stamped on the mounting ears that indicate manufacturing dates.

Data inscribed on the nameplate includes the serial no. combination model/part no. and manufacture date.

IDENTIFYING R-134A COMPRESSORS

R-12 to R134a

SD505	SD5H09
SD507	SD7H13
SD508	SD5H14
SD510	SD7H15 / 5H14HD
SD708	SD7H13
SD709	SD7H15
TR	→ TRS

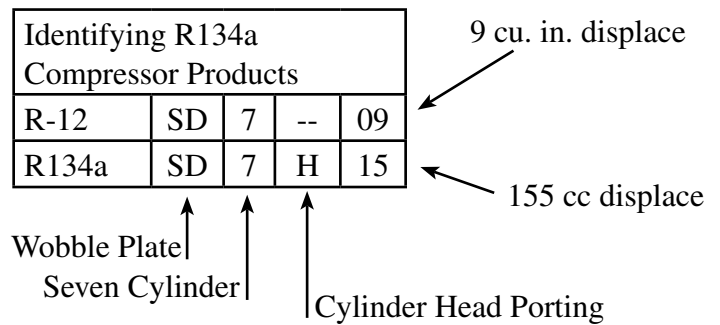

SANDEN COMPRESSORS

OIL CHECK PROCEDURES

It is not necessary to check the oil level as routine maintenance. However, there are circumstances which warrant this inspection. These are: whenever a system component has been replaced; an oil leak is suspected; or whenever it is specified as a diagnostic procedure. If an inspection is warranted, follow the procedure below after repairs have been made.

Step 1 -- Run the compressor for ten (10) minutes at engine idle RPM.

Step 2 -- Recover all refrigerant from the system. Be careful not to lose oil.

Step 3 -- Determine the mounting angle. Position the Angle Gauge across the flat surfaces of the two front mounting ears. Center the bubble. Read the mounting angle to the closest degree. (This will be important in Step 7).

Step 4 -- Remove the oil filler plug. Observe the accompanying figure to determine if the compressor is mounted right or left. Rotate the counterweight located on the front of the clutch until it is at the angle shown relative to the oil filler hole.

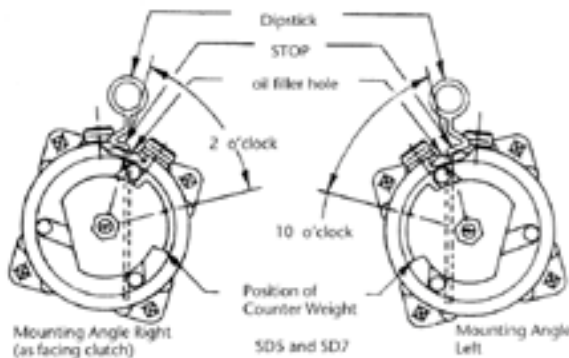

Step 5 -- Insert the dipstick to its STOP position.

(Use Figure above as a guide.) The stop is the angle near the top of dipstick.

- Point of the angle must be to the left if mounting angle is to the right.

- Point of the angle must be to the right if mounting angle is to the left.

- Seat and O-Ring must be clean.

- Check the dipstick to be sure it corresponds to the Sanden recommendation shown.

Step 6 -- Remove dipstick. Count increments of oil.

Step 7 -- Use mounting angle table to determine the correct level for the compressor.

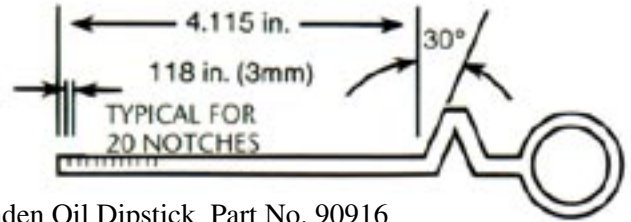

Sanden Oil Dipstick Part No. 90916

Mounting Angle (Degrees)	Acceptable Oil Level In Increments					
	505	507	508	510	708	709
0	4-6	3-5	4-6	2-4	4-6	3-5
10	6-8	5-7	6-8	4-5	5-7	4-6
20	8-10	6-8	7-9	5-6	6-8	5-7
30	10-11	7-9	8-10	6-7	7-9	6-8
40	11-12	8-10	9-11	7-9	8-10	7-9
50	12-13	8-10	9-11	9-10	9-11	8-10
60	12-13	9-11	9-12	10-12	10-12	9-11
90	15-16	9-11	9-12	12-13	11-13	10-13

Step 8 -- If increments read on the dipstick do not match the table, add or subtract oil to the mid-range value. For example, if the mounting angle of the SD-508 is 10°, add oil in one (1) fluid ounce increments until 7 is read on the dipstick.

Step 9 -- Install the oil filler plug.

First check that the sealing O-Ring is not twisted.

Seat and O-Ring must be clean.

Torque plug to 6-9 foot-pounds (0.8 - 1.2 kg-m). Do not over tighten the plug to stop a leak. If plug leaks, replace the O-Ring.



All Sanden R134a compressor feature: Green HNBR seals and Sanden PAG Oil (SP-15)

Part # 51325

Sanden provides field service containers of SP-15 PAG Oil for Sanden SD-Series compressors in convenient 250 cc cans. These cans are designed to withstand moisture injection. Always keep the cap tightly closed when not handling the oil.

























Sanden limits the warranty of SD compressors for the field service with the condition that only Sanden-approved SP-15 is utilized. SP-15 replaces SP-20.

SANDEN COMPRESSOR CYLINDER HEAD TYPES

FIG #	CYLINDER HEAD CONFIGURATION	COMPRESSOR MODELS	PART #
B	Vertical Flare, 3/4" x 7/8" W/Charging Ports	SD508, SD510	CH-1000
C	Vertical Tube O-Ring, 1" x 14 W/O Charging Ports	SD508, SD510, SD5H14	CH-3000
CB	Vertical Tube O-Ring, 1" x 14 W/O Charging Ports	SD708, SD709, SD7H13, SD7H15	CH-5000
E	Vertical Flare, 3/4" x 7/8" W/Charging Ports	SD505, SD507	CH-2000
FC	Vertical O-Ring, 3/4" x 7/8" W/Charging Ports	SD708, SD709	CH-5002
FG	Vertical O-Ring, 3/4" x 7/8" W/Charging Ports	SD508, SD510	CH-1001
FL	Vertical O-Ring, 3/4" x 7/8" W/O Charging Ports	SD5H14	CH-5607
FN	Vertical O-Ring, 3/4" x 7/8" W/O Charging Ports	SD505, SD507	CH-2002
GH	Horizontal GM Pad W/Port for Pressure Relief Valve	SD7H15	CH-4818
GK	Horizontal GM Pad	SD7H15	CH-5614
JD	Vertical O-Ring, 3/4" x 7/8" W/O Charging Ports	SD7H15	CH-5601
JDA	Vertical O-Ring, 3/4" x 7/8" (Diode) W/Port for Pressure Relief Valve	SD7H13, SD7H15	CH-5611
JE	Vertical O-Ring, 3/4" x 7/8" W/O Charging Ports	SD7H13	CH-5612
K	Horizontal O-Ring, 3/4" x 7/8" W/O Charging Ports	SD508, SD510	CH-4000
KB	Horizontal O-Ring, 3/4 x 7/8 W/O Charging Ports, Thick Head	SD508, SD510	CH-5605
KC	Vertical O-Ring, 3/4" x 7/8", Special Terminal, Thick Head	SD7H15	CH-5609
KCA	Vertical O-Ring, 3/4" x 7/8" with pressure relief valve	SD7H15	
KD	Vertical O-Ring, 3/4" x 7/8" Thick Head, Pressure Relief Valve	SD709	CH-5613
KG	Vertical O-Ring 3/4" x 7/8" W/O Charging Ports	SD7H15	CH-5603
M	Horizontal Tube O-Ring, 1" x 14, W/O Charging Ports	SD508, SD510, SD5H14	CH-1003
MD	Horizontal Tube O-Ring, 1" x 14, W/O Charging Ports	SD708, SD709, SD7H13, SD7H15	CH-5001
MJ	Horizontal Tube O-Ring, (Diode), 1" x 14, W/Pressure Relief Valve	SD7H13, SD7H15	CH-5610
N	Vertical Tube O-Ring, 1" x 14, W/ Charging Ports	SD508, SD510	CH-5003
PB	Ported on Body	SD7B10	
QC	Horizontal, GM Pad	SD7H13, SD7H15	CH-5500
QD	Pad Type, M10X 1.25 For Pad Bolt, W/Pressure Relief Valve Port	SD708, SD709	CH-5050
QM	Horizontal, GM Pad	SD510	CH-5608
UB	Vertical Pad Type, 3/4" x 7/8", W/O Charging Ports	SD510	

Sanden R-134a Compressors DO NOT Offer The Option Of Charging Valves On The Compressor.

SANDEN COMPRESSOR CYLINDER HEAD TYPES

				
B	C	CB	E	FC
				
FG/FN	GH	FL	GK	JD
				
JDA	JE	K/KB	KC	KCA
				
KD	KG	M	MD	MJ
				
N	QC	QD	QM	UB

SANDEN COMPRESSORS WITH CLUTCH

SEE ALSO LISTINGS IN RED DOT CATALOG

Part No.	After Market #	Volts	Compressor Type	Dia.	Groove Clutch	Width	Head Type	Oil Charge
4498 *		12	SD7H15SHD	5 1/4"	8	SERPENTINE	KCA	--
4504		12	SD510	5 1/8"	1	1/2"	QM	10 oz
4506 */4507/6665	4506AM	24	SD5H14HD	5 1/4"	2	1/2"	FL	8 oz
4510 */6664/4509	4510AM	12	SD5H14HD	5 1/4"	2	1/2"	FL	7 oz
4511 */6671		12	SD5H14HD	6 1/4"	1	1/2" - 3/4"	C	8 oz
4513 */6631		12	SD5H14	5 1/4"	2	1/2"	M	--
4514 */6629		12	SD5H14	4 3/4"	7	SERPENTINE	FL	--
4515 */6673		12	SD5H14HD	6 1/4"	1	1/2" - 3/4"	FL	8 oz
4516 */6672		24	SD5H14HD	6 1/4"	1	1/2" - 3/4"	FL	7 oz
4519 *		24	SD510HD	5 1/2"	1	1/2"	QM	8 oz
4529 */4525		12	SD5H14HD	5 1/4"	2	1/2"	C	7 oz
4536 */6630/6676		12	SD5H14HD	5 1/4"	2	1/2"	K	--
4537 */6634		24	SD5H14HD	5 1/4"	2	1/2"	K	--
4600 */7865	4600AM	12	SD7H15SHD	5"	6	SERPENTINE	JD	9 oz
4604 */8107	4604AM	24	SD7H15	5 3/8"	1	1/2"	GK	10 oz
4608	4608AM	12	SD7H15SHD	5 1/2"	1	1/2"	GK	10 oz
4609 */4478	4609AM	12	SD7H15SHD	6"	2	1/2"	MD	9.6 oz
4611 *	4611AM	24	SD7H15	6"	2	1/2"	GV	6.7 oz
4617 *	4617AM	12	SD7H15SHD	5 1/4"	2	1/2"	MD	10 oz
4626 * D		12	SD7H15HD	5 1/4"	2	1/2"	JD	10 oz
4627 */4663		12	SD7H15HD	5"	2	1/2"	JD	--
4637 *		12	SD7H15SHD	5 1/4"	8	SERPENTINE	KC	9 oz
4640/4479*/8109	4640AM	24	SD7H15SHD	5 1/2"	1	1/2"	GK	10 oz
4643 *	4643AM	12	SD7H15HD	5 1/4"	2	1/2"	CB	8 oz
4646 *		12	SD7H15	5 1/4"	2	1/2"	MJ	8 oz
4652 *	4652AM	24	SD7H15	5	2	1/2"	JD	8 oz
4653		12	SD7H15	4 1/2"	6	SERPENTINE	CB	6 oz
4661 */4480		12	SD7H15	5 3/8"	1	1/2"	KC	10 oz
4664 */8104		12	SD7H15HD	5 1/4"	2	1/2"	JD	8.11 oz
4673 *		12	SD7H15SHD	5 1/4"	2	1/2"	KC	9.13 oz
4698 * D	4698AM	12	SD7H15SHD	5 3/8"	8	SERPENTINE	JD	10 oz
4709 *		12	SD7H15	4.9	2	1/2"	KG	4.5 oz
4711 */8103	4711AM	12	SD7H15	4 3/4"	8	SERPENTINE	JD	4.5 oz
4736 *		12	SD7H15	5"	2	1/2"	JDA	--
4738 *		12	SD7H15SHD	5 1/4"	8	SERPENTINE	JE/JD	9 oz
4768 */4499		12	SD7H15SHD	6"	8	SERPENTINE	MD	9.6 oz

(1) Rear Top Mounting Ear Removed For Clearance

(2) Horizontal Tube O Manifold Included

* = R134a Compressor Sanden R-134a compressors do not have charging valves or flare fittings.

D = Direct Mount DL=Direct Long Mount

Compressor Type with HD (Sample SD7H15 HD) has a Heavy Duty Bearing.

Compressor Type with SHD (Sample SD7H15 SHD) has a special dust protection, plus Heavy Duty Bearing.

SANDEN COMPRESSORS WITH CLUTCH

SEE ALSO LISTINGS IN RED DOT CATALOG

Part No.	After Market #	Volts	Compressor Type	Dia.	Groove Clutch	Width	Head Type	Oil Charge
4769 * /4301	4769AM	24	SD7H15SHD	5 1/4"	8	SERPENTINE	GK	10 oz
4778		12	SD7H15	5 1/4"	2	1/2"	WV	--
4840 * /4302		24	SD7H15SHD	6"	8	SERPENTINE	GK	--
5072 *		12	SD5H09	5"	2	1/2"	FL	2.38 oz
5425		12	SD508	6 1/4"	1	1/2" - 3/4"	FG	--
5708		12	SD510	5 1/4"	2	1/2"	KB	4.5 oz
5752		12	SD510	5 1/4"	2	1/2"	N	--
5791	5791AM	12	SD510	5"	6	SERPENTINE	UB	8 oz
6332*	6332AM	12	SD5H11	5"	2	1/2"	C	4.5 oz
7170*	7170AM	12	SD7B10	4 1/2"	2	1/2"	PB	3.4 oz
7409		12	SD709	5"	2	1/2"	FC	--
7819 */7851		12	SD7H15	5"	2	1/2"	MD	5 oz
7862 *		12	SD7H15HD	5 1/4"	2	1/2"	KG	4.5 oz
7948 *		24	SD7H15	5 1/4"	1	1/2"	MD	--
7952 *		12	SD7H15HD	5 1/2"	2	1/2"	QC	6.4 oz
7975 *		12	SD7H15SHD	6"	2	1/2"	CB	8 oz
8026 *	8026AM	12	SD7H15	5"	6	SERPENTINE	JE	4.5 oz
8147 * D		12	SD7H15	4 1/2"	4	SERPENTINE	QC	--
8148 * D		12	SD7H15	4 1/2"	4	SERPENTINE	WV	--
8279		12	SD7H15	4 1/2"	4	SERPENTINE	KG	--
8387	8387AM	12	SD508	6"	2	1/2"	B	6 oz
8390	8390AM	12	SD508	5 1/4"	2	1/2"	B	6 oz
9056		12	SD505	5"	2	1/2"	E	3.4 oz
9076		12	SD505	5"	2	1/2"	C	--
9077		24	SD505	5"	2	1/2"	E	--
9103	9103AM	12	SD510HD	5 1/4"	2	1/2"	B	4.56 oz
9105		24	SD510HD	5 1/4"	2	1/2"	B	--
9114		12	SD510HD	5 1/4"	2	1/2"	C	4.56 oz
9119		12	SD510HD	6 1/4"	1	1/2" - 3/4"	C	8.11 oz
9120 /5742	9120AM	12	SD510HD	5 1/4"	2	1/2"	FG	4.56 oz
9122		24	SD510HD	6 1/4"	1	1/2" - 3/4"	C	--
9125	9125AM	12	SD510HD	5 1/4"	2	1/2"	M	4.56 oz
9133		24	SD510HD	5 1/4"	2	1/2"	C	--
9263		12	SD508	5 1/4"	2	1/2"	N	5.91 oz
9285		12	SD508	5 1/4"	2	1/2"	FG	5.91 oz
9514		12	SD508HD	4 3/4"	1	1/2"	FG	--

(1) Rear Top Mounting Ear Removed For Clearance

(2) Horizontal Tube O Manifold Included

* = R134a Compressor Sanden R-134a compressors do not have charging valves or flare fittings.

D = Direct Mount DL=Direct Long Mount

Compressor Type with HD (Sample SD7H15 HD) has a Heavy Duty Bearing.

Compressor Type with SHD (Sample SD7H15 SHD) has a special dust protection, plus Heavy Duty Bearing.

SANDEN COMPRESSORS WITH CLUTCH

SEE ALSO LISTINGS IN RED DOT CATALOG

Part No.	After Market #	Volts	Compressor Type	Dia.	Groove Clutch	Width	Head Type	Oil Charge
9515		12	SD508HD	5 1/4"	2	1/2"	FG	5.91 oz
9519		12	SD508HD	5 1/4"	2	1/2"	C	--
9571/9588	9571AM	12	SD508	6"	2	1/2"	M	8.11 oz
9663		12	SD510HD	4 3/4"	7	SERPENTINE	FG	--
9674		24	SD510HD	5 1/4"	2	1/2"	FG	--
9675		12	SD510HD	6 1/4"	1	1/2" - 3/4"	FG	--
9676		24	SD510HD	6 1/4"	1	1/2" - 3/4"	FG	--
CO09397 *		12	SD5H11	5"	2	1/2"	FL	4.5 oz
CO09399 * D		24	SD7H13	5"	1	1/2"	WM	--
CO093991 * D		24	SD7H13	5 3/4"	1	5/8"	WL	--
CO093998 *		12	SD7H13	4.6"	8	SERPENTINE	KG	--
CO09407 *		12	SD508	6 1/4"	1	1/2" - 3/4"	B	6 oz
CO095981 *		12	SD7H15	5 3/8"	1	1/2"	MD	6.8 oz
CO095984 * D		24	SD7H15	4.7"	8	SERPENTINE	MD	4.5 oz
CO095986 *		12	SD7H15	4 3/4"	8	SERPENTINE	MD	135 cc
CO09610 * (1) (2)		12	SD7H15	5 1/2"	2	1/2"	QC	6.4 oz
CO09612 * (2)		12	SD7H15	5 1/2"	2	1/2"	QC	6.4 oz
CO096384 * D		12	SD7H15	4.6"	4	SERPENTINE	KG	--
CO096394 * D		12	SD7H15	4 3/4"	4	SERPENTINE	MD	--
CO096395 * D		12	SD7H15	5 3/4"	4	SERPENTINE	MD	--
CO096396 * D		12	SD7H15	4 3/4"	6	SERPENTINE	QC	--
CO096471 *		--	SD7H15	--	10	SERPENTINE	--	--

(1) Rear Top Mounting Ear Removed For Clearance

(2) Horizontal Tube O Manifold Included

* = R134a Compressor Sanden R-134a compressors do not have charging valves or flare fittings.

D = Direct Mount DL=Direct Long Mount

Compressor Type with HD (Sample SD7H15 HD) has a Heavy Duty Bearing.

Compressor Type with SHD (Sample SD7H15 SHD) has a special dust protection, plus Heavy Duty Bearing.

Seltec Compressors

Part No.	Volts	Compressor Type	Dia.	Groove Clutch	Width	Head Type	Oil Charge
CO06765	12	TM-08	5"	2	1/2"	V-O'Ring	5.7 oz
CO06785	12	TM-16HD	6"	2	1/2"	GM Pad	6 oz

Part No. Label
(identifies mfg. part no.)

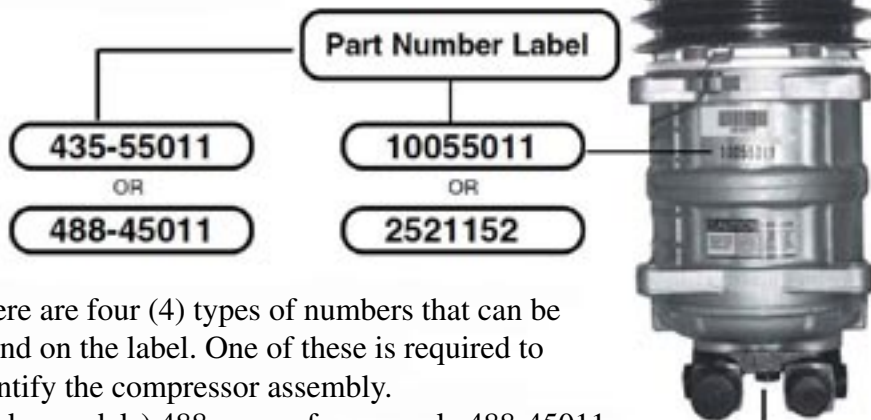

There are four (4) types of numbers that can be found on the label. One of these is required to identify the compressor assembly.
 (Older models) 488-xxxxx for example 488-45011
 (Newer models) 435-xxxxx for example 435-55011
 (Newer models-Valeo brand) 10055011
 (ICE brand) 252xxxx for example 2521141

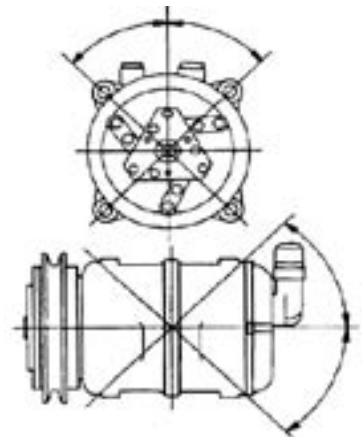

Acceptable Mounting Angles

Basic Seltec/Valeo Compressor Specifications					
Model	Refrigerant	Displacement cu. in. (c.c.)	Oil Type	Oil Charge Amt (oz)	Rotation
TM8HD	R134a	5.2	ZXL100	5 oz	CW or CWW
TM15D	R12 - R134a	9	Note 1	5 oz	CW or CWW
TM16HD (3)	R134a	9.7	ZXL100	5.5 oz	CW or CWW
TM21HX	R134a	13.1	ZXL100	6.9 oz	CW or CWW
TM31HD (4)	R134a	15.6	ZXL100	8.7	CW

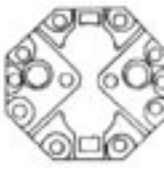
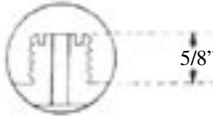

Notes:

1. If retrofitting system to R134a, follow Seltec's retrofit procedures for changing oil types. For R12 systems, Seltec recommends the use of Freol DS-83P. Seltec R12 compressors are factory equipped with mineral oil. R134a compressors are factory equipped with PAG oil.
2. Amounts shown are standard factory recommendations only. For systems with unusually long hose lengths, or with more than 56 oz of refrigerant charge, consult manual. Also when ever a component in the system has been flushed or replaced, or a leak is suspected, the oil level in the compressor should be checked.
3. TM16HD compressors can handle up to approximately 40,000 BTU evaporator output.
4. TM31 is designed for bus and transit applications

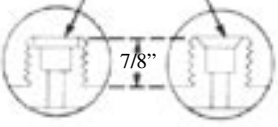
(TCCI) York Compressor Head Types				
Type	Diagram	Gasket	Part No.	Illustrated
Flange		Square Cut O'Ring	20172 51541	
Rotolock		Teflon Square Cut	20525	
Tube O		Rubber O'Ring	53618	
Earlier models used a gasket (as illustrated). Later models use the Square Cut O'Ring (not illustrated.)				

York (CCI) Compressor			
Head Style	Suction	H.P.R.V.	Part No.
Flange	R.H.	Yes	7032
Tube "O"	L.H.	Yes	7036
Tube "O"	R.H.	Yes	7040
Rotolock	L.H.	Yes	7044
Rotolock	R.H.	Yes	7054

LH = LEFT HAND SUCTION FACING SHAFT
RH = RIGHT HAND SUCTION FACING SHAFT

HPRV = HIGH PRESSURE RELIEF VALVE (Opens at about 400 PSI)
Part No. 650-675

If compressor is mounted laying on it's side the suction side should be on top.

We do not stock York (TCCI) remanufactured compressors.
• York compressors are now manufactured by Climate Control (TCCI)

IMPORTANT: To insure protection of the system ALWAYS install a Filter Drier/Accumulator and Expansion Valve/Orifice Tube when replacing the compressor.

(TCCI) YORK COMPRESSOR - IDENTIFICATION

NOMENCLATURE

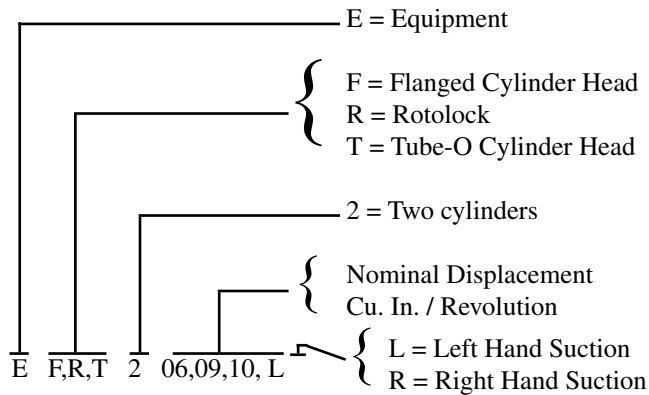

IDENTIFICATION

The metal nameplate located at the top front of the compressor serves as a means of identification. The location permits viewing the nameplate with the clutch installed.

Data inscribed on the nameplate includes the serial number, combination model and part number and designates the manufacturing period.

1. The serial number of equipment design (E) compressors has an "A" prefix and the standard design (S) has an "M" prefix.

Models 206, 209, 210 differ in the stroke and therefore in displacement. The various models may be identified by the difference in machining of the ends of the shaft. Refer to detail "A".

LEFT HAND MOUNTING

CHECK OIL WHEN NON ROK SHAFT
KEY IS DOWN

RIGHT HAND MOUNTING

CHECK OIL WHEN NON ROK SHAFT
KEY IS UP.

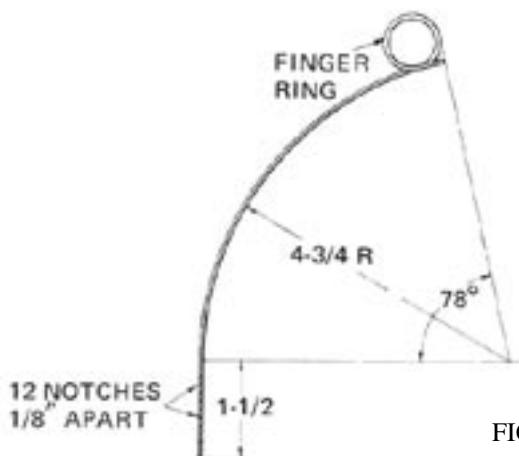

FIG. 1 - OIL DIP STICK PART NO. 90431

(TCCI) YORK COMPRESSOR OIL LEVEL CHECK

The table below shows the crankcase oil charge in ounces at various dip stick measurements for both horizontal and vertical mounts. The oil charge after system is stabilized should be maintained between 6 ounces minimum and 10 ounces maximum for best results.

OIL CHARGE Vs. DIP STICK DEPTH					
Oil Charge, Ounces	6	8	10	12	16
Horizontal Mount	13/16"	1"	1 3/16"	1 5/8"	1 15/16"
Vertical Mount	7/8"	1"	1 1/8"	1 7/16"	1 7/8"

Nippondenso Compressor

Part No.	Volts	Compressor Type	Clutch Dia.	Grooves	Groove Width	Oil Oz
CO03104	24	6E171/ 10H20E	5 3/4"	1	1/2"	5 oz
CO03116	12	6E171	5 3/4"	1	1/2"	8 oz
CO03119	12	10PA15C	5 3/8"	2	1/2"	5.4 oz
CO03120	12	10PA15C	4 7/8"	8	SERPENTINE	5.4 oz
CO031219	12	10PA15C	5 1/8"	9	SERPENTINE	6 oz
CO03122	24	10PA15C	6"	1	5/8"	--
CO031224	24	10PA15C	5 1/4"	1	1/2"	--
CO031226	24	10PA15C	6"	1	1/2"	--
CO03124	24	10S15C	6"	1	5/8"	6 oz
CO03125	12	10PA17C	5 3/4"	1	1/2"	--
CO03130	12	10PA17C	5 3/4"	1	1/2"	7.8 oz
CO03133 *	--	10PA17C	--	--	--	7.7 oz
CO03135	12	10PA17C	5 3/4"	1	1/2"	7.8 oz
CO03139	12	10PA17C	5"	6	SERPENTINE	8 oz
CO03140	12	10PA17C	5 3/4"	8	SERPENTINE	8 oz
CO03143	24	10PA17C	4 7/8"	8	SERPENTINE	8 oz
CO03145	24	10PA17C	5 3/4"	8	SERPENTINE	7.8 oz
CO03150	24	10PA17C	5 3/4"	1	1/2"	7.8 oz
CO03161	24	10S17C	5 3/8"	1	1/2"	--
CO03168	24	10S17C	5 1/2"	8	SERPENTINE	--
CO03170	12	SCSA06C	4 7/8"	1	1/2"	2.5 oz
CO03175	12	SCS06	4 7/8"	1	1/2"	3 oz
CO03180	12	10P0E	4 7/8"	1	1/2"	4.5 oz
CO03184 *	--	SCSA06C	--	--	--	--
CO03185	12	SCSA06C	4 1/8"	6	SERPENTINE	3 oz
CO03290	12	7SBU16C	5"	9	SERPENTINE	--

* NO Clutch



CO03104



CO03116



CO03119



CO03120



CO031219



CO03122



CO031224

**NO PIC
CO031226**



CO03124



CO03125



CO03130



CO03133



CO03135



CO03139



CO03140



CO03143



CO03145



CO03150



CO03161



CO03168



CO03170



CO03175



CO03180



CO03184



CO03185



CO03290

Nippondenso Compressor Parts

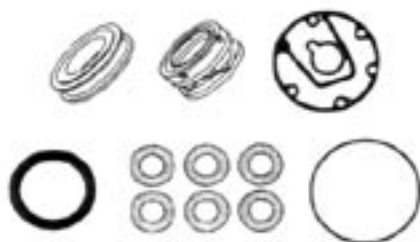

20840
Fits Nippondenso 6E171
(Wave spring type carbon seal)



20841
10PA15C or E, 10PA17A, C, K,
VC, 10PA20C Shaft Seal Kit



451-1170
John Deere Nippondenso Suction Manifold
Fits CO03116
For Ear Mount Nippondenso Compressor



451-1172
John Deere Nippondenso Discharge Manifold
Fits CO03116



650-670
John Deere Nippondenso Pressure
Relief Valve, Thread 12mm, 1.00 Pitch



451-1179
John Deere Nippondenso Manifold



451-1173K
John Deere Nippondenso
Manifold Kit For CO03116
Compressor



451-1185
John Deere 55 and 60 Series Compressor Manifold

Sanden Compressor Gaskets

O-Rings Fiber Gaskets



GA-1342



GA-1336



GA-4466-KT



GA-4488-KT

Part No.	Application/Description
GA-1336	Sanden SD505, 507, 508, 510 Cylinder Head Gasket
GA-1342	Sanden SD708, 709 Cylinder Head Gasket
GA-4466-KT	Rubber Coated Metal Gasket Kit SD505, 507, 508, 510, 5H14
GA-4488-KT	Rubber Coated Metal Gasket Kit SD7H15

COMPRESSOR SHAFT SEAL KITS York-Tecumseh

75R6530



Diesel Kiki-Seltec

20938

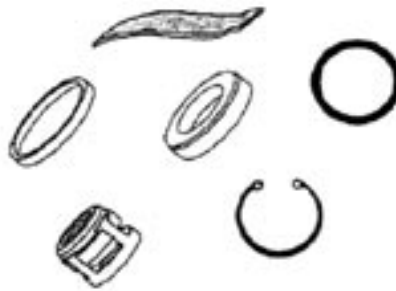

Fits GM A-6 & R-4 Ceramic with Felt Wiper (Full)

20939



GMA6, R4 Metal Shaft Seal Kit

52552



Fits Sanden SD508, SD510

52553





Fits Sanden SD708, SD709

52554







Fits Sanden Lip Seal SD5H, SD7H



COMPRESSOR SHAFT SEAL KITS York-Tecumseh

<p>20986</p>  <p>Fits York Compressor 206 Mini 210 6 bolt (1/4" Bolt Head)</p>	<p>20836</p>  <p>Fits Tecumseh / HG 1000 2 1/16" Dia. (Large Front Bearing) Blissfield HGB1000</p>	<p>20698</p>  <p>Fits York/Tecumseh HG 1000, 850 6 bolt (3/8" Bolt Head)</p>
------------------------------------------------------------------------------------------------------------------------------------------------------------------------------	----------------------------------------------------------------------------------------------------------------------------------------------------------------------------------------------------	----------------------------------------------------------------------------------------------------------------------------------------------------------------------------



COMPRESSOR PRESSURE RELIEF VALVE

<p>650-675</p>  <p>York-Sanden-Pressure Relief Valve 3/8" x 24 Thread</p>	<p>5686A</p>  <p>Sanden Pressure Relief Valve 3/8" x 24 Thread</p>	<p>650-670</p>  <p>John Deere Nippondenso Relief Valve, Thread 12mm, 1.00 Pitch</p>
<p>650-680</p>  <p>10mm - 1.50 Pitch</p>		







COMPRESSOR CONVERSION KITS

	Part Number & Description	Kit Includes:
	<p>MD90001 R4 to Sanden Conversion Kit Kit includes new Hi-side hose Replaces R-4 Compressor AGCO/ALLIS 6060, 6070</p>	<p>Compressor Mounting Bracket Mounting Hardware Belt Binary Switch Retrofit Adaptors Hose O'Ring</p>
	<p>MD90005 A6 to Seltec Conversion Kit Adapts to the original A6 mounting brackets AGCO/ALLIS 7000, 7020</p>	<p>Compressor Mounting Bracket Mounting Hardware Belt Binary Switch Compressor Manifold O'Ring</p>





COMPRESSOR CONVERSION KITS

Part Number & Description		Kit Includes:
	<p>MD90008 A6 or R4 to Seltec Conversion Kit Replaces A-6 and R-4 Compressor AGCO/ALLIS 4W-220, 7030, 7040, 7045, 7050, 7060, 7580, 8070</p>	Compressor Mounting Bracket Mounting Hardware Belt Binary Switch Compressor Manifold Retrofit Adaptors O'Ring
<p>NO PIC</p>	<p>MD900086 Complete Conversion Kit Fits: 7030, 7040, 7050 Agco/Allis Tractors and 7000, 7060, 7080 Red Frame Agco/Allis Tractors</p>	Compressor Hoses O-Rings Expansion Valve Receiver Drier
<p>NO PIC</p>	<p>MD900087 Complete Conversion Kit Fits: 7045, 7060, 7080 Black Frame Agco/Allis Tractors</p>	Compressor Hoses O-Rings Expansion Valve Receiver Drier
	<p>MD90010 A6 or R4 to Seltec Conversion Kit With Cummins Engine Uses Original Hoses Tractors With Cummins 8.3 Conversion AGCO/ALLIS 8030, 8050, 8070</p>	Compressor Mounting Bracket Mounting Hardware Belt Binary Switch Retrofit Adaptors
	<p>MD90012 A6 or R4 to Seltec Conversion Kit Replaces A-6 and R-4 Compressor AGCO/ALLIS 4W-305, 8550</p>	Compressor Mounting Bracket Mounting Hardware Belt Binary Switch Compressor Manifold Retrofit Adaptors O'Ring
	<p>MD90014 A6 to Seltec Conversion Kit Tractors With 5.9 Cummins Engine</p>	Compressor Mounting Bracket Mounting Hardware Belt Binary Switch Compressor Manifold O'Rings





COMPRESSOR CONVERSION KITS

	Part Number & Description	Kit Includes:
	MD900186 A6 To Sanden Conversion Kit 12V Replaces A6 Compressor Using Four Lower Mounting Holes	Compressor Mounting Bracket Mounting Hardware Binary Switch Compressor Manifold Retrofit Adapters O'Rings
	MD90119 York to Sanden Compressor Replaces York Compressor CASE/IH 2090, 2094, 2290, 2294, 2390, 2394, 2590, 2594, 3294, 3394, 3594	Compressor Mounting Bracket Mounting Hardware Belt Service Valves O'Rings
	MD90121 A6 to Seltec Conversion Kit 4 wheel drive tractors Uses original hose and top tensioner bracket Replaces A6 Compressor CASE/IH 4490, 4494, 4690, 4694, 4890, 4894	Compressor Mounting Bracket Mounting Hardware Belt
	MD90123 A6 to Seltec Conversion Kit 70 Series 4WD Replace A6 Compressor CASE/IH 2470, 2670, 2870	Compressor Mounting Bracket Mounting Hardware Belt Binary Switch Compressor Manifold O'Rings
	MD90125 York to Sanden Conversion Kit Replaces York Compressor CASE/IH 1270, 1370, 1570	Compressor Mounting Bracket Mounting Hardware Service Valves O'Rings
	MD90129 York to Seltec Conversion Kit Uses original hoses Replaces York Compressor CASE/IH 2470	Compressor Mounting Bracket Mounting Hardware Belt Compressor Manifold Service Valves O'Rings

COMPRESSOR CONVERSION KITS

Part Number & Description		Kit Includes:
	<p>MD90171 A6 to Sanden 12 Volt Replaces A6 Compressor with Various Side Mount Applications</p>	Compressor Mounting Bracket Mounting Hardware Binary Switch Compressor Manifold Retrofit Adaptors O'Rings
<p>NO PIC</p>	<p>MD90182 A6 to Sanden Cat Heavy Offroad 12 Volt Replaces A6 Compressor</p>	Compressor Mounting Bracket Mounting Hardware Binary Switch Compressor Manifold Retrofit Adaptors
	<p>MD90184 A6 to Sanden Cat Heavy Offroad 24 Volt Replaces A6 Compressor</p>	Compressor Mounting Bracket Mounting Hardware Binary Switch Compressor Manifold Retrofit Adaptors O'Rings
	<p>MD90200 Rotary Tecumseh HR980 to Sanden Conversion Kit Replaces HR980 Rotary Tecumseh Compressor May require additional purchase of fan spacers, Part # 995-201 FORD TW5, TW15, TW35</p>	Compressor Mounting Bracket Mounting Hardware Binary Switch Hoses O'Rings
	<p>MD90210 Rotary Tecumseh HR980 to Sanden Conversion Kit Replaces HR980 Rotary Tecumseh Compressor Includes 8oz. Ester Oil for R134a Applications FORD 6610, 6710, 6810, 7410, 7610</p>	Compressor Mounting Bracket Mounting Hardware Hoses O'Rings

COMPRESSOR CONVERSION KITS

Part Number & Description		Kit Includes:
	<p>MD90215 Rotary Tecumseh HR980 to Seltec Conversion Kit Replaces HR980 Rotary Tecumseh Compressor Includes 8oz. Ester Oil for R134a Applications FORD 5610, 7710</p>	Compressor Mounting Bracket Mounting Hardware Compressor Manifold Hoses O'Rings
	<p>MD90220 Rotary Tecumseh HR980 to Seltec Conversion Kit Replaces HR980 Rotary Tecumseh Compressor Includes 8oz. Ester Oil for R-134a Applications FORD 7810</p>	Compressor Mounting Bracket Mounting Hardware Compressor Manifold Hoses O'Rings
	<p>MD90225 Rotary Tecumseh HR980 to Sanden Conversion Kit Replaces HR980 Rotary Tecumseh Compressor Includes 8oz. Ester Oil for R-134a Applications FORD 7910, 8210</p>	Compressor Mounting Bracket Mounting Hardware Compressor Manifold Hoses O'Rings
	<p>MD90230 Tecumseh, York Upright to Seltec Conversion Kit Replaces York, Tecumseh Upright Compressor Includes 8oz. Ester Oil for R-134a Applications FORD 9700, TW5, TW10, TW15, TW20, TW30, TW35</p>	Compressor Mounting Bracket Mounting Hardware Binary Switch Compressor Manifold Hoses O"Rings
	<p>MD90235 Tecumseh, York Upright to Sanden Conversion Kit Replaces York Compressor FORD 6610, 7710</p>	Compressor Mounting Bracket Mounting Hardware Compressor Manifold Hoses

COMPRESSOR CONVERSION KITS

Part Number & Description		Kit Includes:
	MD90240 York to Seltec Conversion Replaces York Compressor FORD 7700	Compressor Mounting Bracket Mounting Hardware Belt Compressor Manifold Hoses O'Rings
	MD90245 Tecumseh York Upright to Seltec Conversion Kit Uses Original Belt	Compressor Mounting Bracket Mounting Hardware Binary Switch Hoses O'Rings
	MD90270 Tecumseh, York Upright to Sanden Conversion Kit Replaces York, Tecumseh Upright Compressors	Compressor Mounting Bracket Mounting Hardware Belt Compressor Manifold Service Valves
	MD90286 Tecumseh, York Upright to Seltec Conversion Kit Replaces York, Tecumseh Upright Compressors	Compressor Mounting Bracket Mounting Hardware Belt Service Valves O'Rings
	MD90340 York to Sanden Conversion Kit Replaces York Compressor INTERNATIONAL 3388, 3588, 3788, 4568, 4586, 4786 COMBINE -- 1420, 1620	Compressor Mounting Bracket Mounting Hardware Belt Compressor Manifold O'Ring





COMPRESSOR CONVERSION KITS

Part Number & Description		Kit Includes:
	<p>MD90345 York to Sanden Conversion Kit 6388, 6588, 6788 Tractors must purchase Hi-Side Hose Part # 7-1250493S Replaces York Compressor CASE/IH COMBINE 1822, 6388, 6588, 6788, 7288, 7488 INTERNATIONAL COMBINE 1640</p>	<p>Compressor Mounting Bracket Mounting Hardware Belt Compressor Manifold Service Valves O'Ring</p>
	<p>MD90352 International York to Sanden Conversion Kit 5088 Thru 5488 Series Allows the use of original hoses and original belt</p>	
<p>NO PIC</p>	<p>MD903528 International York to Sanden Conversion Kit 88 Series Uses original belt and hoses</p>	<p>Compressor Hoses Drier Expansion Valve Roof Foam</p>
	<p>MD90357 York to Sanden Conversion Kit Order 451-6265K to replace original service valves, universal kit-use for Flare & O'Ring applications INTERNATIONAL 100 HYDRO, 186 HYDRO, 766, 786, 966, 986, 1066, 1466, 1468, 1486, 1566, 1568, 1586, 4166, 4186, 4366, 4386, COMBINE -- 615, 715, 815, 915</p>	<p>Compressor Mounting Bracket Mounting Hardware Compressor Manifold O'Rings</p>
<p>NO PIC</p>	<p>MD903576 International 86 Series O-Ring Conversion Kit</p>	<p>Compressor Hoses Receiver Drier Expansion Valve Service Valve O'Rings Roof Foam</p>



COMPRESSOR CONVERSION KITS

Part Number & Description		Kit Includes:
NO PIC	MD903577 International 86 Series O-Ring Conversion Kit	Compressor Hoses Receiver Drier Expansion Valve Service Valve O'Rings Roof Foam
	MD90358 York to Sanden Conversion Kit - Aftermarket - Order 451-6265K To Replace Original Service Valves, Universal Kit - Use for Flare & O-Ring Applications	Compressor Mounting Bracket Mounting Hardware O'Rings
	MD90360 York to Sanden Conversion Kit Uses original belt INTERNATIONAL 886 with German Diesel, 3288	Compressor Mounting Bracket Mounting Hardware O'Ring
	MD90365 A6 to Seltec Conversion Kit 6600 John Deere Combines Replaces York Compressor	Compressor Mounting Bracket Mounting Hardware Compressor Manifold O'Ring
	MD90370 York to Sanden Conversion Kit Replaces York, Tecumseh Upright Compressors GLEANER N5, N6	Compressor Mounting Bracket Mounting Hardware Belt Compressor Manifold Service Valves O'Ring
	MD90373 York to Seltec Conversion Kit Uses original belt and hoses Replaces York, Tecumseh Compressors GLEANER M2, M3	Compressor Mounting Bracket Mounting Hardware Compressor Manifold Service Valves O'Ring

COMPRESSOR CONVERSION KITS

	Part Number & Description	Kit Includes:
	<p>MD90375 York to Sanden Conversion Kit Replaces York, Tecumseh Upright Compressors Replaces York, Tecumseh Compressors GLEANER R40, R42, R52</p>	<p>Compressor Mounting Bracket Mounting Hardware Belt Compressor Manifold Service Valves O'Ring</p>
	<p>MD90377 York to Sanden Conversion Kit Uses Original Belt-Fits Flare and O'Ring Applications Replaces York Upright Compressor to Sanden</p>	<p>Compressor Mounting Bracket Mounting Hardware Compressor Manifold Service Valves Retrofit Adapters O'Rings</p>
	<p>MD90380 York to Sanden Conversion Kit Replaces York, Tecumseh Upright Compressors With Cummins Engine GLEANOR R42, R52</p>	<p>Compressor Mounting Bracket Mounting Hardware Belt Compressor Manifold Service Valves</p>
<p style="text-align: center;">NO PIC</p>	<p>MD90381 York to Sanden Conversion Kit Uses Shorter Belt, Fan Removal Required Replaces York, Tecumseh Compressor With Cummins Engine</p>	<p>Compressor Mounting Bracket Mounting Hardware Belt Service Valves</p>
	<p>MD90400 A6 to Seltec Conversion Kit Kit allows for the use of the original hoses and belt Replaces A6 Compressor JOHN DEERE 2955, 3140 COMBINE 6600, 9910, 9920</p>	<p>Compressor Mounting Bracket Mounting Hardware Binary Switch Retrofit Adaptors</p>
	<p>MD90401 A6 to Seltec Conversion Kit Kit allows for use of original belt Replaces A6 Compressor</p>	<p>Compressor Mounting Bracket Mounting Hardware Binary Switch Retrofit Adaptors</p>







COMPRESSOR CONVERSION KITS

Part Number & Description		Kit Includes:
	<p>MD90403 A6 to Seltec Conversion Kit Kit allows for the use of the original hoses Replaces A6 Compressor JOHN DEERE 4000, 4020, 4040, 4230, 4240, 4320, 4430, 4440, 4520, 4620, 4630, 5020, 6030, 7520, 8430, 8440, 8630, 8640 COMBINE 6600, 7700, 7720, 7722, 9940 FORAGE HARVESTOR 5400, 5440, 5460, 5720</p>	Compressor Mounting Bracket Mounting Hardware Binary Switch Compressor Manifold Retrofit Adaptors O'Ring
	<p>MD90404 A6 to Sanden Conversion Kit Kit allows for use of original hoses and belts Replaces original A6 Compressor</p>	Compressor Mounting Bracket Mounting Hardware Binary Switches Compressor Manifold Retrofit Adaptors O'Rings Pressure Switch R134a adapters
	<p>MD90405 A6 to Seltec Conversion Kit Kit allows for the use of the original hoses Replaces A6 Compressor JOHN DEERE 4640, 4840 COMBINE 9940</p>	Compressor Mounting Bracket Mounting Hardware Binary Switch Compressor Manifold Retrofit Adaptors O'Ring
	<p>MD90406 A6 to Sanden Conversion Kit Kit allows for use of original hoses Replaces A6 Compressor</p>	Compressor Mounting Bracket Mounting Hardware Binary Switches Compressor Manifold Retrofit Adaptors O'Rings
<p>NO PIC</p>	<p>MD90408 Nippondenso Ear Mount To Sanden Kit allows for the use of original hoses and belts</p>	Compressor Mounting Bracket Mounting Hardware Compressor Manifold Retrofit Adaptors O'Rings

COMPRESSOR CONVERSION KITS

	Part Number & Description	Kit Includes:
	MD90411 A6 to Seltec Conversion Kit Kit includes new Compressor hoses Replaces A-6 Compressor JOHN DEERE 4040, 4230, 4240, 4430, 4440, 4630	Compressor Mounting Bracket Mounting Hardware Binary Switch Retrofit Adaptors Hoses
	MD90412 A6 to Sanden Conversion Kit Replaces A6 Compressor	Compressor Mounting Bracket Mounting Hardware Binary Switch Retrofit Adaptors Hoses O'Rings
	MD90414 A6 to Sanden Conversion Kit Kit includes new compressor hoses Replaces A-6 Compressor JOHN DEERE 4840	Compressor Mounting Bracket Mounting Hardware Binary Switch Retrofit Adaptors Hoses O'Rings
	MD90415 Nippondenso to Sanden Conversion Kit 50, 55, 60 Series Row Crop Tractors Replaces Nippondenso Compressor JOHN DEERE 4050, 4055, 4255 4450, 4455, 4560, 4650, 4755, 4760, 4850, 4955, 4960, 8450, 8560	Compressor Mounting Bracket Mounting Hardware Binary Switch Compressor Manifold Retrofit Adaptors O'Rings
	MD90416 Nippondenso Ear Mount To Sanden Conversion Kit Eliminate thread stripping of original manifold & hoses	Compressor Mounting Bracket Mounting Hardware Binary Switch Retrofit Adaptors Hoses O'Rings
NO PIC	MD904164 John Deere Complete R-134a Conversion Kit Nippondenso to Sanden with 6466 Engine Only	





COMPRESSOR CONVERSION KITS

Part Number & Description		Kit Includes:
	MD90417 Nippondenso Ear Mount To Sanden Conversion Kit Eliminates thread stripping of original manifold and hoses	Compressor Mounting Bracket Mounting Hardware Binary Switch Retrofit Adaptors Hoses O'Rings
	MD90418 A6 to Seltec Conversion Kit 8820 John Deere Combines	Compressor Mounting Bracket Mounting Hardware Binary Switch Retrofit Adaptors
	MD90420 A6 to Seltec Conversion Kit Brackets mount to original A6 mounting brackets Uses Original Hoses JOHN DEERE 1640, 2040, 2040S, 2250, 2350, 2450, 2555, 2650, 2750, 2755, 2850, 2855N, 4030	Compressor Mounting Bracket Mounting Hardware Belt Binary Switch Compressor Mainfold Retrofit Adaptors O'Rings
	MD904212 John Deere Complete R-134a Conversion Kit	Compressor Hoses Receiver Drier Expansion Valve O'Rings
	MD90423 A6 to Seltec Conversion Kit Uses original belt and hoses 2270, 2280 Swathers	Compressor Mounting Bracket Mounting Hardware Binary Switch Compressor Manifold O'Rings
	MD90425 Nippondenso to Sanden Conversion Kit JOHN DEERE 8650, 8760 Tractors Only Replaces Nippondenso Compressor	Compressor Binary Switch Compressor Manifold Retrofit Adaptors





COMPRESSOR CONVERSION KITS

Part Number & Description		Kit Includes:
	<p>MD90426 Nippondenso to Sanden conversion kit Uses original belt</p>	<p>Compressor Mounting Bracket Mounting Hardware Compressor Manifold Service Valves Retrofit Adapters O'Rings</p>
	<p>MD90428 Nippondenso to Sanden Conversion Kit Uses original belt and hoses 9400, 9500, 9600, Series JD Combines</p>	<p>Compressor Mounting Bracket Mounting Hardware Binary Switch Compressor Manifold Service Valves O'Rings</p>
	<p>MD90431 Nippondenso Ear Mount to Sanden Conversion Kit 50, 55 Series Utility Tractors Replaces Nippondenso compressor with rotary style compressor</p>	<p>Compressor Mounting Bracket Compressor Manifold O'Rings</p>
	<p>MD90500 A6 to Seltec Conversion Kit Kit allows for the use of the original hoses Adapts to the original A6 mounting brackets MASSEY FERGUSON 1080, 1085, 1100, 1105, 1130, 1135, 1150, 1155, 2705, 2745, 2775, 2805, 3505, 3525, 3545, 4800, 4840, 4880, 4900</p>	<p>Compressor Mounting Bracket Mounting Hardware Binary Switch Compressor Manifold Service Valves O'Ring</p>
	<p>MD90502 York Rotary to Seltec Conversion Kit Replaces original York Rotary Style Compressor Massey Ferguson 285</p>	<p>Compressor Mounting Bracket Mounting Hardware Hoses O'Rings</p>

COMPRESSOR CONVERSION KITS

	Part Number & Description	Kit Includes:
	<p>MD90505 Massey Ferguson Conversion Kit A6 to Sanden Replaces OE R4 Bracket Assembly and A6 OE Bracket Assembly Massey Ferguson 550 Combine</p>	<p>Compressor Mounting Bracket Mounting Hardware Binary Switch Compressor Manifold Retrofit Adapters O'Rings</p>
	<p>MD90519 R4 to Sanden Conversion Kit 5.9L Cummins Engine Kit allows for use of original hoses Must remove compressor mounting bracket adapter plate from engine.</p>	<p>Compressor Mounting Bracket Mounting Hardware O'Rings</p>
<p style="text-align: center;">NO PIC</p>	<p>MD90520 R4 to Sanden, 8.3 L Cummins Engine - Kit allows for use of the original hoses</p>	<p>Compressor Mounting Bracket Mounting Hardware Belt O'Rings</p>
	<p>MD90660 York to Seltec Conversion Kit Kit allows for the use of the original hoses Replaces York Compressor</p>	<p>Compressor Mounting Bracket Mounting Hardware Compressor Manifold Service Valves O'Rings</p>
	<p>MD90665 York to Seltec Conversion Kit Kit allows for the use of original hoses Replaces York Compressor</p>	<p>Compressor Mounting Bracket Mounting Hardware Compressor Manifold Service Valves O'Rings</p>
	<p>MD90676 York to Sanden Conversion Kit Replaces York Compressor</p>	<p>Compressor Mounting Bracket Mounting Hardware Belt Compressor Manifold Service Valves</p>

COMPRESSOR CONVERSION KITS

Part Number & Description		Kit Includes:
	<p>MD907010 Case/IH Magnum Series Conversion Kit</p>	<p>Compressor Hoses Receiver Drier Expansion Valve O-Rings</p>
	<p>MD909002 York to Sanden aftermarket 2 groove short body replacement kit, 1/2" belt applications. 1.66C, 2.28 F gasuge line Use for 2 groove applications with 1.66 gauge line from center of front side mounting hole to center of first groove of clutch Replaces York/Tech compressors equipped with 2 groove clutch and left hand tube o'ring fittings</p>	
	<p>MD9090026 York to Sanden aftermarket 2 groove 6: dia. short body replacement kit, 1/2" belt application 1.66C, 2.28F gauge line Use for 2 groove applications with 1.66 gauge line from center of front side mounting hole to center of first groove of clutch Replaces York/Tech compressors equipped with 2 groove clutch and left hand tube o'ring fittings</p>	
	<p>MD95010 R4 to A6 Conversion Bracket Kit Converts R-4 to A-6 Compressor AGCO/ALLIS 4W-220, 8070</p>	<p>Mounting Hardware Belt</p>
	<p>MD95430 John Deere A6 to Sanden bracket kit Mounts to JD 6404, 6466 engines Use with ear mount Sanden or Seltec compressor</p>	

COMPRESSOR CONVERSION KITS

Part Number & Description		Kit Includes:
	<p>MD9180014 York to Sanden 1 groove long body replacement kit, 1/2" thru 3/4" belt application, 2.82 gauge line Requires a minimum of 2 1/2" of clearance for rear head from original York take off for 5/8" belt applications Replaces York/Tech 1 groove with 2.82" gauge line, measure from front side mounting hole to center groove of clutch on original York</p>	
	<p>995-201 Ford Fan Spacer-Sanden Conversion</p>	
	<p>995-300 York to Sanden Swing Bracket</p>	
	<p>995-450 Converts early 30 series tractors to later style steel cab lines</p>	
	<p>995-473 Quick coupler bracket for MD90415 kit 8450, 8650 John Deere applications</p>	

