

**SERVICE
INSTRUCTION
MANUAL
FOR**

Jacobs®

ELECTRIC RETARDER

MODELS:

**J-300, J-320, J-500,
J-520, J-720
(12 VOLT)**

**J-520, J-720,
J-740, J-920
(24 VOLT)**

Jacobs®

Vehicle Equipment Division
The Jacobs Manufacturing Company
Bloomfield, Connecticut 06002 U.S.A.

This manual contains information on the operation and maintenance of the Electric Retarder.

The manual contains enough information for the general maintenance of the Electric Retarder and its components. Any repairs that are not covered or outlined in this manual should be done by a Jacobs approved distributor.

Before starting an inspection test or repair, total familiarization of all components and procedures is mandatory. Proper operation, maintenance and repair procedures will ensure excellent performance and dependable operation.



**STATEMENTS MARKED WITH THIS SYMBOL
ARE IMPORTANT FOR THE SAFE USE AND
CARE OF THE JACOBS ELECTRIC RETARDER.**



SECTION INDEX

SECTION I:	DESCRIPTION OF THE ELECTRIC RETARDER	PAGE 2
SECTION II:	COMPONENT DESCRIPTION AND OPERATION FOR THE ELECTRIC RETARDER	PAGE 3
SECTION III:	ELECTRIC RETARDER MAINTENANCE	PAGE 5
SECTION IV:	REPAIR AND INSPECTION PROCEDURES	PAGE 7
SECTION V:	TORQUE SPECIFICATIONS	PAGE 15
SECTION VI:	TROUBLE SHOOTING AND WIRING SCHEMATICS	PAGE 16

SECTION I

Description of The Retarder

The Jacobs Electric Retarder is a drive line mounted, power absorbing device which, unlike wheel brakes, does not depend upon friction to generate a retarding force. It consists of two air cooled steel rotors mounted on a solid shaft which is, in turn, supported by large tapered roller bearings. (Refer to illustration below)

An array of powerful D.C. electromagnets is attached to the stationary frame of the retarder unit with the steel end pole pieces separated from the inner face of the rotors by a small air gap. The rotors are cast in the form of centrifugal fans which pump cooling air through the rotors continuously.

The retarding force is developed by the action of the rotor shearing through lines of magnetic force produced by electrically energized coils. As in wheel brakes, considerable heat is generated. However in the retarder, the heat is produced by the flow of electrical currents within the rotors themselves and is dissipated by the flow of air through the rotors. As a result, the force reacts on the driveline of the vehicle and slows the vehicle down.

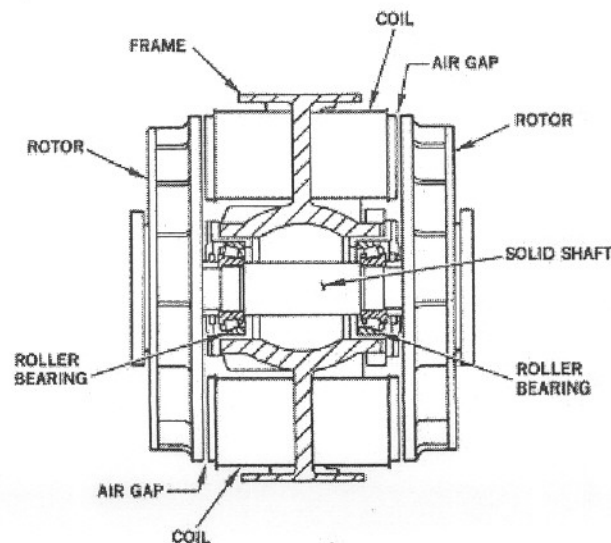

SECTION II

Component Description And Operation for The Electric Retarder

What Is A Jacobs Electric Retarder?

The Jacobs Electric Retarder — Jake“ER”® is a self-contained unit that is attached to the vehicle driveline. It consists of a number of stationary electromagnets and two rotating discs, or rotors. When activated, the electric retarder generates powerful electric currents in the rotating discs. These currents result in retarding force which is transmitted to the vehicles' driveline.



Jake“ER”® IS A VEHICLE SLOWING DEVICE NOT A VEHICLE STOPPING DEVICE. IT IS NOT A SUBSTITUTE FOR THE SERVICE BRAKING SYSTEM. THE VEHICLE'S SERVICE BRAKES MUST BE USED TO BRING THE VEHICLE TO A COMPLETE STOP.

Location And Operation of Controls

The controls for Jake“ER”® are divided into two categories: Driver-Operated and Automatic.

Driver-operated Controls:

- **The Master “ON-OFF” switch** is located on the dashboard of the vehicle. It must be turned to the “ON” position in order to activate the retarder. Normally, the switch should be in the “ON” position whenever the vehicle is in use.
- **Multipositional switches:**
Note: Either hand or foot controls are installed on a vehicle. Both the hand-control and the foot-control are multipositional switches. Activating either one through its successive positions progressively increases retarding power. As soon as the control is placed in the first operating position, a dash-mounted indicator light* is illuminated.
- **Hand-control switch** is usually mounted on the steering column. It must be manually engaged by moving the lever to various positions (1st, 2nd, 3rd, 4th) for desired retarding force. When the vehicle has stopped, the selector lever should be placed in the “OFF” position, or discharging of the batteries will occur. At the same time, the dash mounted indicator light* will go out.



CAUTION: NEVER ACCELERATE WITH VEHICLE IN THE RETARDING MODE, ALWAYS RELEASE ACCELERATOR PEDAL BEFORE ENERGIZING THE RETARDER.

- **The Foot-Control Switch** is mounted in such a way as to be activated when the brake pedal is depressed slowly through each position. There are 4 positions available for the desired retarding power before the service brakes are actually applied.
- **Retarder Reserve Switch** is dash mounted and located for operating convenience. By pushing the switch down and holding, 4th position is automatically energized when hand or foot control is in 4th position.

Some light duty differentials are not capable of handling the full four positions of retarder output without experiencing premature wear on the gearing. In these applications the retarder's capability for normal operation is restricted to a fixed number of positions.

The Retarder Reserve Switch use should be limited to situations where additional retarding is required to compensate for retarder fade on long downhill grades. The switch should be used intermittently along with service brakes.

*If the vehicle is equipped with a low speed shut-off switch, the dashboard indicator light will not come ON until the vehicle has exceeded 8 mph (12 km/hr.) and the light will go OUT when the vehicle's speed is below 5 mph (8 km/hr.)

Automatic Controls:

The following controls are automatic:

- **Contact (Relay) Box** connects Jake "ER"® to the electrical system of the vehicle. It is normally located in an area where exposure to contaminants is minimized. Vehicles are equipped with contactor boxes with or without time delay. Contactor boxes with time delay provide a slight delay between positions 2 and 3, and 3 and 4 to prevent sudden torque increases to rearend components.



ADJUSTMENTS TO THE CONTACTOR BOX SHOULD ONLY BE MADE BY AN AUTHORIZED DISTRIBUTOR.

- **Low Speed Shut-Off Switch** is usually located in series with the speedometer drive, and is located either at the speedometer, transmission, or at the front wheel. It can be used with either hand control or foot control switches. The switch automatically turns the retarder off at road speeds below 5 mph (8 km/hr.), this prevents battery drain while vehicle is stopped.



THE SERVICE BRAKES MUST BE USED TO BRING THE VEHICLE TO A COMPLETE STOP.

NOTE: Dashboard indicator light is usually located near the master switch and is illuminated when the hand or foot control is actuated, not by the master switch.

IF THE VEHICLE IS EQUIPPED WITH A LOW SPEED SHUT-OFF SWITCH, THE DASHBOARD INDICATOR LIGHT WILL NOT COME ON UNTIL ROAD SPEED IS ABOVE 8 mph (12 km/hr.)

Operation of The Jacobs Electric Retarder

Jake "ER"® may be used for descending grades, in city traffic, approaching stop lights, and in general whenever vehicle retarding is required. Use of Jake "ER"® leaves the service brakes cooler, and more effective, for emergency stops. The more you use your Jake "ER"® the less you use your service brakes.

The multi-position control system on the Jake "ER"® provides variable retarding for various road and traffic conditions. When it is necessary to slow down, step through your positions until you get the desired rate of deceleration. Service brakes should be used for final stopping, or when more rapid braking is required. Since operation of any vehicle under slippery conditions is unpredictable, a good general rule is to gradually apply each position for best control of your vehicle.



TOO MUCH RETARDING TOO FAST CAN CAUSE LOSS OF CONTROL

Extended Retarder Use

When the Jake "ER"® is used for extended periods of time, heat build-up will occur, resulting in diminished performance. The heat build-up is a function of time and switch position.

It is recommended that when long descents are encountered (5 minutes or more), the appropriate vehicle speed be obtained using the retarder in second (2nd) position. During long descents, third and fourth positions must only be used for short periods of time to minimize the heat build-up and the possibility of bearing damage. Select 3rd and 4th positions as the retarding force decays.

After descending long grades, and the rotors are hot, a cool down period of at least 5 minutes is necessary. Keep the vehicle moving so that the retarder rotors continue to rotate (minimum 15 mph) with the retarder turned off. The cooling period is necessary to prevent overheating.

Does Engine RPM Affect Jake "ER"®?

Engine rpm does not affect Jake "ER"® retarding power.

Does Vehicle Speed Affect Jake "ER"®?

Jake "ER"® performance is proportional to drive shaft rpms (i.e., road speed) so more retarding power is available as drive shaft rpms are increased.

Do's And Don'ts of Operating The Jake "ER"®

- DO turn on master switch whenever the vehicle is in use.
- DO release accelerator pedal before energizing any retarder position.
- DO use service brakes to bring the vehicle to a complete stop.
- DO position hand control switch to the "OFF" position when vehicle has stopped to prevent battery drain.
- DO allow for cool down period of the rotors after long descents, at least 5 minutes while vehicle is moving.
- DO operate your Jacobs Electric Retarder carefully under slippery road conditions.
- DO NOT use Retarder when accelerating.
- DO NOT use 4th position for long durations on long descents to avoid overheating.



DO NOT INSTALL ELECTRIC RETARDER ON VEHICLES CARRYING FLAMMABLE LOADS. ELECTRIC RETARDER SHOULD NOT BE USED IN EXPLOSIVE ATMOSPHERES.

SECTION III Electric Retarder Maintenance

Normally the only maintenance Jake "ER"® requires is an occasional "wash down" of the unit with water and periodic lubrication of the bearings.

NORMAL "WASH-DOWN": Allow rotors to cool to the touch, then hose them down with high pressure water. Make sure all dirt is dislodged from cooling fins of rotors and around coils.

- DO NOT wash while the retarder is hot or damage could occur.
- DO NOT use any sharp instruments to dislodge dirt from around coils or damage to the coils could result.
- DO NOT use caustic solution in wash down as it will initiate terminal corrosion.
- Off-highway vehicles require more frequent care of keeping cooling fins dislodged of dirt due to environment.

Lubrication

Lubrication intervals depend on the severity of the operation, number of miles traveled, and amount of retarder use. In general, it is recommended that Jake "ER"® be lubricated at the intervals shown below with a high quality NLGI Grade 2 Lithium base grease with 180°C (356°F) minimum drop point. Typical lubricants are as follows:

MANUFACTURER	TYPE
Molykote	BR2-S
Mobil	Mobilgrease MP
Shell	EP Alvania 2
Texaco	Regal AFB2

The Electric Retarder must be greased with an approved lubricant. A quantity of grease 2.5-3.0 oz. (70-85 gr.) shall be added in accordance with the following schedule:

First 4,500 Miles	Every 1,500 Miles
After 4,500 Miles	Long Distance over Highway Every 4,000 Miles
	City usage school bus, ambulance, utility vehicle — Every 2,000-2,500 miles
CONTINUOUS HEAVY USAGE — EVERY 4 HOURS OF USE	

At each grease interval, check vent tube for obstruction; pass small diameter wire .03 in (.76 mm) approx. 6" long up vent hole to insure an open passage. "DO NOT TURN SOCKET SCREW IN VENT AS DAMAGE WILL OCCUR."

Periodic Inspection Checklist (Perform Every 25,000 Miles)



- VERIFY THAT WIRES DO NOT RUN ADJACENT TO GAS, AIR AND HYDRAULIC LINES.**
- CHECK WIRES FOR ABRASION**
- INSPECT TO SEE IF SAFETY LOOPS AROUND DRIVE SHAFT ARE SECURE.**
- Check point gap per Procedure III, Page 11.
- Inspect flange and mounting bolts on Retarder. If they are missing or loose, replace and torque to values on Page 15, Table 1.
- Inspect rubber shock mounts for the Retarder and related hardware. If damaged, replace as shown in Procedure I, Page 7.
- Inspect condition of Electric Retarder electrical wiring, if damaged repair or replace as shown in Procedure V, Page 12.
- *Inspect for evidence of a grease leak by checking backside of the rotors and surrounding area. It may mean a faulty grease seal.
- Check air gap (See Procedure VII, Page 15).
- Check rotors for distortion, See Procedure II, Page 9.
- Inspect hand or foot control for mechanical operation.
- If equipped with low speed switch inspect for operation and installation. Refer to automatic controls, Page 4.
- Check for corroded terminals and connections. Replace as required using correct method and crimping tools. See Procedure V, Page 12.
- *Visually inspect all welds on mounting hardware of the Retarder for separations and cracks. Check all hardware and frame rails for fatigue cracks or bending.
- Inspect coils for damage.
- Inspect for excess heating on chassis due to rotor heat build-up. Insulate as required.
- *Check for excessive end play as described in Procedure IV, Page 12.



**CAUTION: IF END PLAY IS NOT TO SPECIFICATIONS,
SEVERE DAMAGE COULD OCCUR.**

NOTE: If the vehicle is equipped with a low speed shut-off switch it must be electrically by-passed before inspecting the following items. (See Wiring Schematic, Page 17.)

- Inspect dash indicator light by energizing hand or foot control, after master switch is in the "ON" position. Replace bulb if not operating.
- Remove cover of contactor box and check condition of relays, contact points and operation by activating foot or hand control after master switch has been electrically energized.



**Disconnect Batteries before Attempting Inspection
or Maintenance of the Retarder and Controls unless
Otherwise Noted.**



*If the indicated conditions exist, they should be corrected by a Jacobs Authorized Distributor.

SECTION IV

Repair And Inspection Procedures

- PROCEDURE I, PAGE 7
Remove And Replace Press-in And Bolt-in Rubber Shock Mounts
- PROCEDURE II, PAGE 9
Checking Rotors For Distortion From Overheating
- PROCEDURE III, PAGE 10
Replacing And Adjusting Relay Points In Contactor Box
- PROCEDURE IV, PAGE 12
Checking For Excessive End Play On Roller Bearings
- PROCEDURE V, PAGE 12
Replacing Damaged Wires Or Corroded Terminals
- PROCEDURE VI, PAGE 14
Checking Coil Amperage Draw
- PROCEDURE VII, PAGE 15
Checking Air Gap

Equipment Required for Repairs and Inspection

- Heavy duty transmission jack (1000 lbs. min. capacity)
- Metric sockets and wrenches (5 mm to 27 mm)
- D.C. shunt ammeter (0-300 amp. scale)
- Wire and cable crimpers for #14 awg. to #1/0 awg.
- Dial indicator (.000- .030 in.)
- Arbor press ½ ton capacity
- Feeler gauges (.000-.025 in.)
- Torque wrenches (10-50 lbs. in.) and (35-90 lb.ft.)

Procedure I

- A) Removing Press-in Type Rubber Mount
- B) Removing Bolt-in Type Rubber Mount

A) Removing Press-in Type Mount

Step 1

Using transmission jack to cradle retarder, jack up retarder until the weight is taken off the rubber mounts.

Step 2

Remove both large support bolts (18 mm) on the damaged side.

Step 3

Remove side support plate bolts (14 mm) and remove side support plate.

Step 4

Press out damaged rubber mount as shown in Figure 1.

Step 5

Press in new mount (Note direction of ass'y.) until bottomed on bracket and install in the proper direction using special installation tool P/N 004648). As shown in Figure 2, Page 8.

Step 6

Reverse procedure to reassemble. (Note order of ass'y. of hardware, see Figure 1). Torque all bolts per Table 1, Page 15.

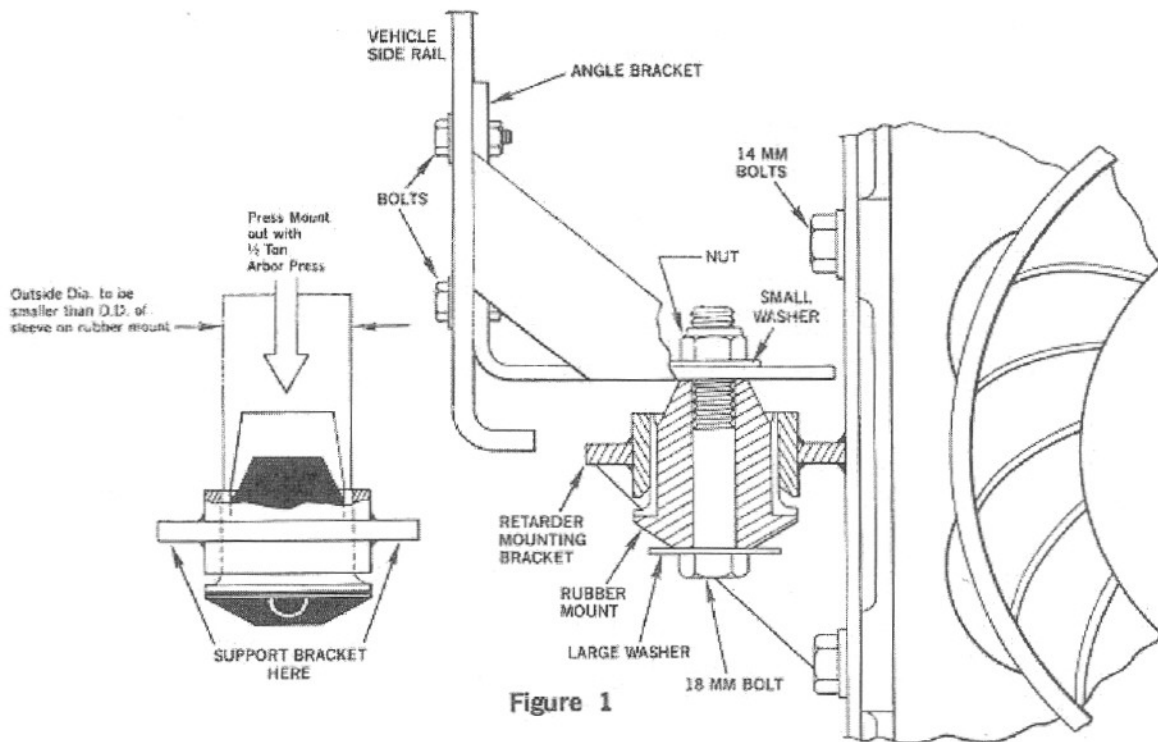

Figure 1

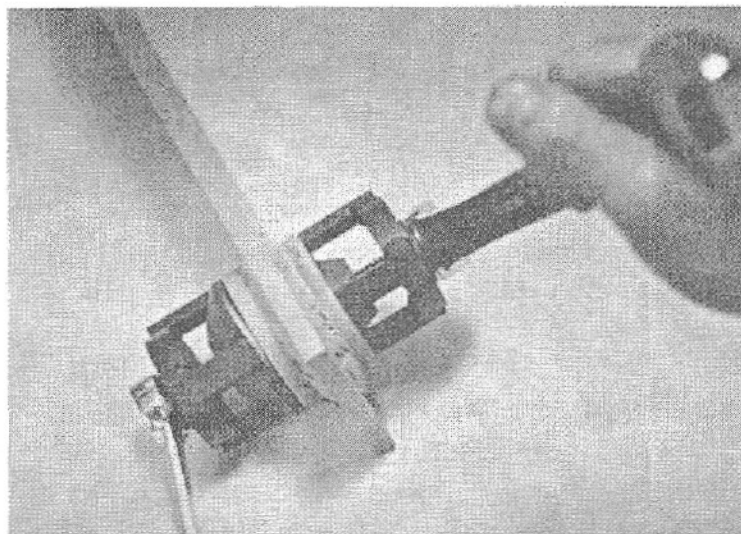

Figure 2

B) Removing Bolt-in Type Mount

Step 1

Using transmission jack to cradle retarder, jack up retarder until the weight is taken off the rubber mounts.

Step 2

Remove large support bolt (18 mm) from damaged mount.

Step 3

Remove the (3) 8 mm bolts from rubber shock mount and remove shock mount. (Note direction of assy.)

Step 4

Install new shock mount. (Note direction of assy.)

Step 5

Reverse procedure to reassemble. Torque all bolts per Table 2, Page 15.

Procedure II

Checking Rotors For Distortion From Over-Heating.

Preferred Method

Step 1

Connect dial indicator to frame of retarder.

Step 2

Dial Pointer to "0" on dial after stylus is placed against rotor's inside face as shown in Figure 3.

Step 3

Mark rotor at indicator's position and rotate rotor 360° (one revolution). If dial indicator registers more than .025 in. (.635 mm) total indicator reading a correction must be made.

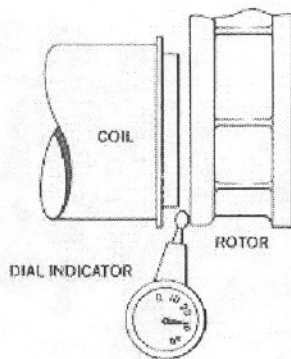

Figure 3

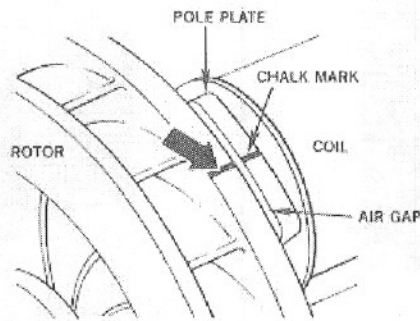

Figure 4

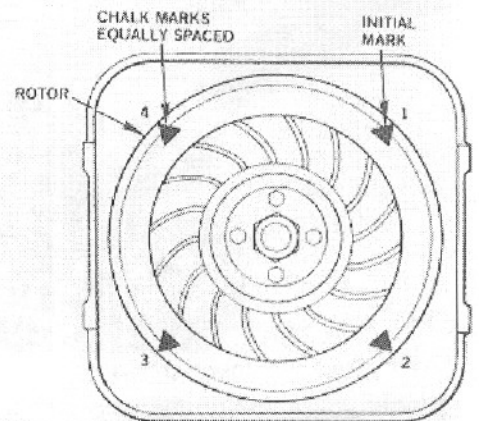

Figure 5

Alternate Method

Using A Feeler Gauge Proceed As Follows:

Step 1

Mark one (1) pole plate and (1) position adjacent to each other on the rotor with colored chalk. Figure 4

Step 2

Mark off 3 other positions on the rotor as illustrated. Figure 5

Step 3

Line up one mark on rotor with marked pole plate and measure air gap with a feeler gauge and record.

Step 4

Measure the air gaps at the other 3 positions on the rotor at the same pole plate and record.

Step 5

Subtract the lowest (smallest air gap) reading from the largest (largest air gap) reading. If the number is greater than .025 in. (.635 mm), a correction must be made. (See Example)

CONSULT YOUR DISTRIBUTOR

Example: Model 520 has around .04 in. (0.10 mm) air gap.

Initial Reading @ Mark # 1 = .045 in. air gap
Rotate Rotor for Reading @ Mark # 2 = .050 in. air gap
Rotate Rotor for Reading @ Mark # 3 = .039 in. air gap
Rotate Rotor for Reading @ Mark # 4 = .058 in. air gap

Now subtract the lowest reading from the highest reading.

Mark # 4 .058 Air Gap
Mark # 3 -.039 Air Gap
 .019 Total Runout

Thus, .019 in. (.609 mm) is within the .025 in. (.635 mm) that we specify.

Procedure III

Replacing And Adjusting Relay Points in Contactor Box



OBSERVE THE SAME PRECAUTIONS YOU WOULD IN WORKING WITH ANY HIGH AMPERAGE BATTERY ENERGIZED SYSTEM BEFORE REMOVING CONTACTOR BOX COVER.

Procedure to replace pitted or burned points (Lower & Upper)

Procedure to adjust and set point gap. See Figures 6 & 7.

Remove upper points by removing hardware as shown.

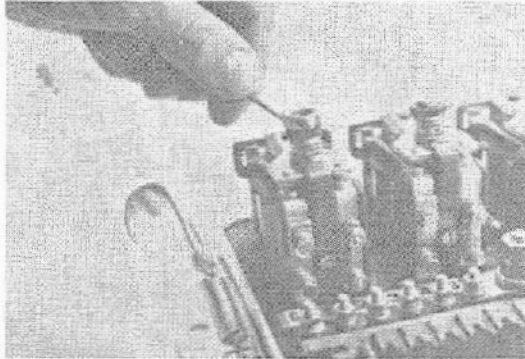

STEP 1 Remove upper crown nut.

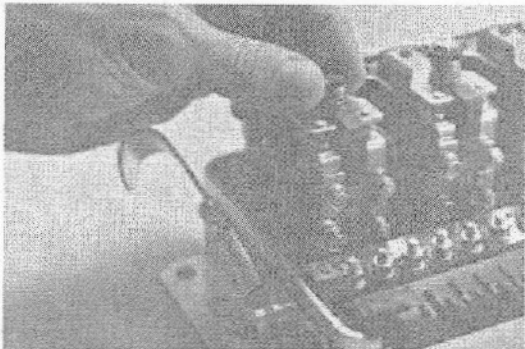

STEP 2 Remove black plastic nut and hardware for spring.

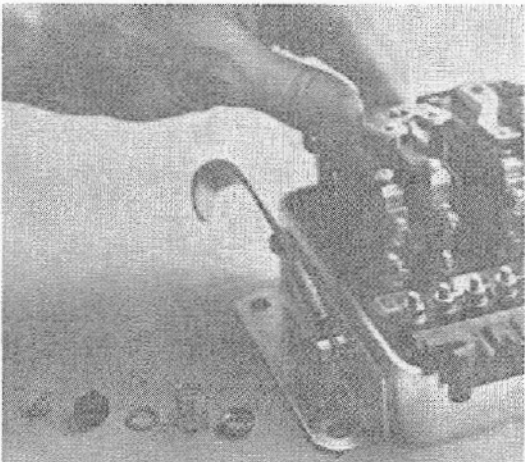

STEP 3 Remove upper points and install new points by reversing procedure. See Figure 7, page 11 for setting black plastic nut height to preload spring. After setting hold in place and tighten crown nut.

Remove lower points by removing hardware as shown.

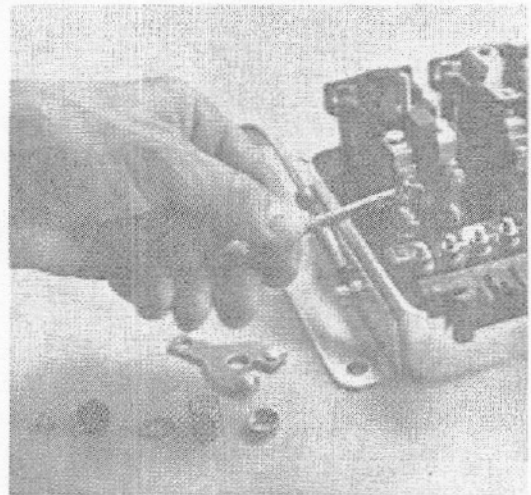

STEP 1 Remove screws and nuts as shown.

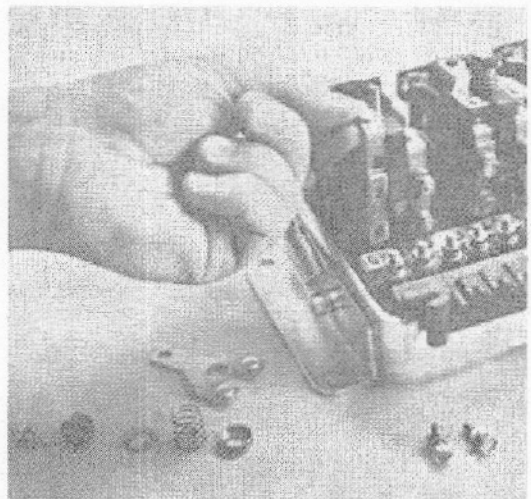

STEP 2 Slide out points and install new points by reversing procedure. Do not tighten screws until point gaps are set.

STEP 3

Set gap as shown using feeler gauge .045-.050 in. (1.14-1.27 mm).



CAUTION: ALWAYS CHECK THIS GAP PRIOR TO INSTALLATION OF NEW UPPER OR LOWER POINTS, THEN PROCEED TO STEP 5.

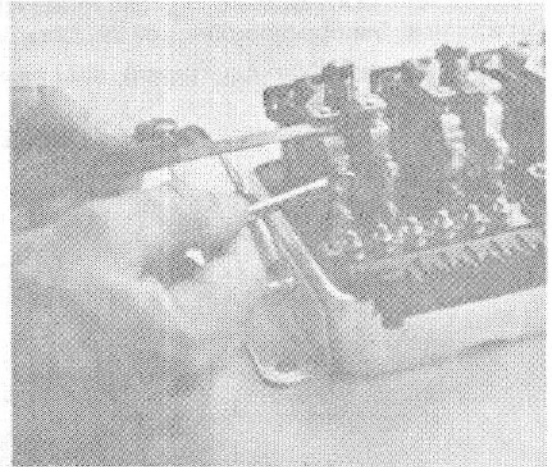
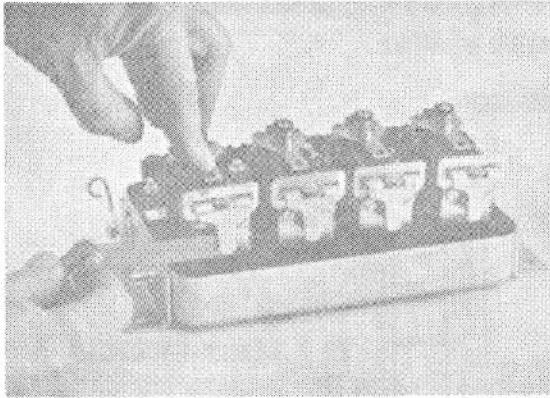

STEP 4 Press down on upper points until armature bottoms on Point "A", see Fig. 6, then set gap by bending tab on armature with needle nose pliers or slightly tapping in tab with plastic hammer as required.
(See Illustration Figure 6 for details)

STEP 5 Set Point Gap as shown using feeler gauge .047-.059 in. (1.194-1.498 mm).
Loosen screws as shown and set each lower point separately to gap specified.
(See Illustration Figure 7 for details.)

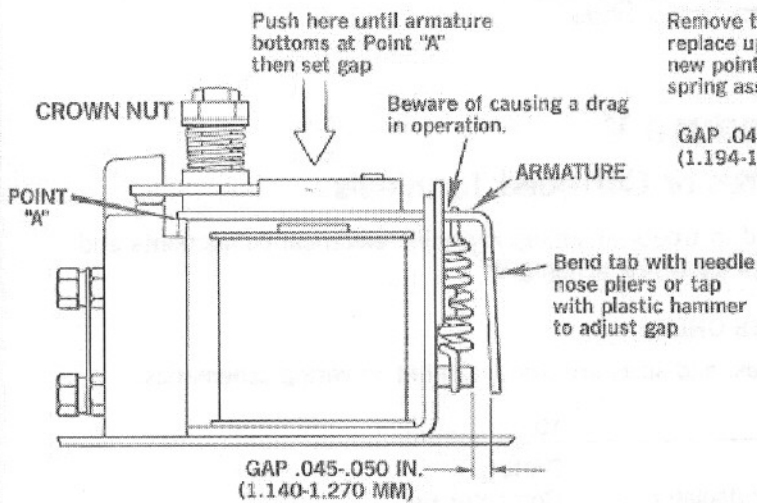

Figure 6

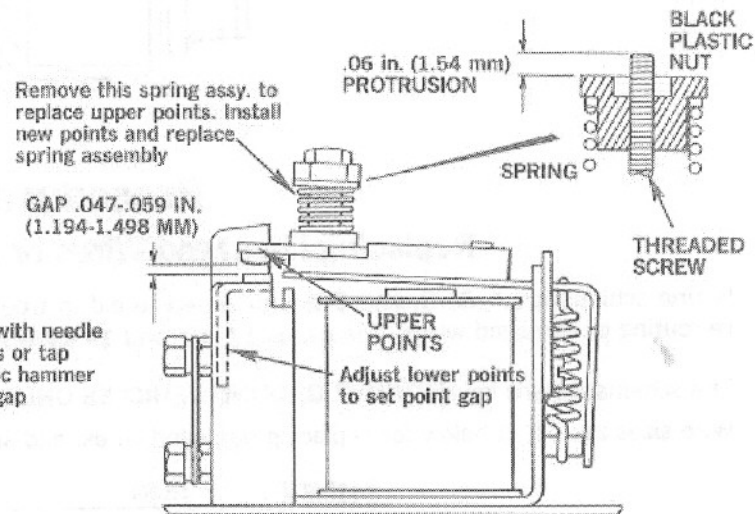

Figure 7



CAUTION: WHEN TIGHTENING SCREWS AND NUTS DO NOT OVER-TIGHTEN.

See Table 2, Page 15 For Torque Specifications.

Procedure IV To Check for Excessive Play on Roller Bearings

- Step 1**
Disconnect flange yokes from Retarder.
- Step 2**
Set up dial indicator as shown in illustration. Exert a force as shown (approx. 100 lbs. maximum), while holding pressure set dial indicator at "0", then release the exerted force. Now without moving the dial indicator, exert a force against the opposite flange of the Retarder and take the reading from the dial indicator.
If reading exceeds .004 in. (.10 mm), then bearing end play must be adjusted.

CONSULT YOUR DISTRIBUTOR

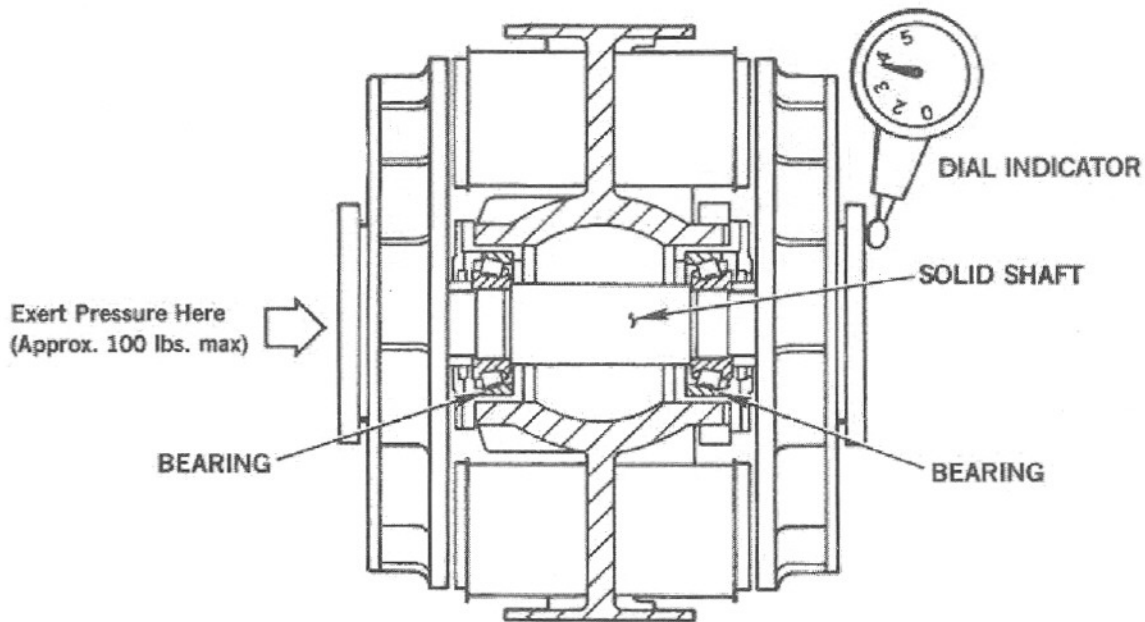

Procedure V Replacing Damaged Wires or Corroded Terminals

Wiring schematics A, B, C, and D are provided to aid in troubleshooting, replacing electrical components and re-routing of damaged wires. See pages 17, 18, and 19 for wiring schematics.

The schematics are for **NEGATIVE GROUND VEHICLES ONLY**.

Wire sizes are listed below for replacing damaged wires, and sizes are also indicated on wiring schematics.

WIRE SIZE	FROM	TO
#1/0 AWG	Battery DUVAC®/Isolator Alternator Retarder	Battery Contactor Box DUVAC®/Isolator Ground
#6/4 AWG	Contactor Box	Electric Retarders Main Terminal Block
#16/4 AWG	Hand Control and Foot Control Units	Contactor Box

NOTE: For All General Low Current Wiring #14 AWG Should Be Used

When replacing terminals on wire ends for contactor box, note order of assy. when replacing wires.
(See Illustration)

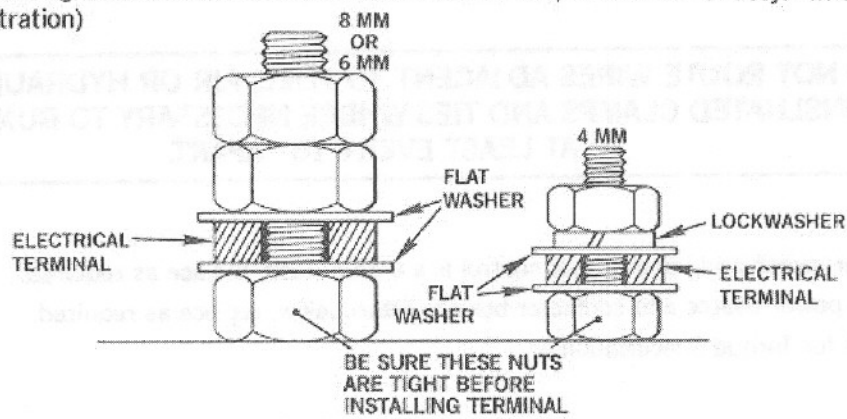

Terminal Chart

JACOBS PART NO.	AMP [®] PART NO.	TYPE OF TERMINAL	FOR WIRE SIZE	STUD SIZE	MATERIAL AND COATING
007805	321598	Solistrand Ring Tongue	#6 AWG	1/4"	Tin Coated Copper
007806	321867	Solistrand Ring Tongue	#1/0 AWG	5/16"	"
007807	321866	"	"	1/4"	"
007808	36919	"	"	1/2"	"
007809	36918	"	"	7/16"	"
007810	31902	PIDG Ring Tongue	#14-16 AWG	8 mm	"
007811	31903	"	"	10 mm	"
007812	60211-2	PIDG Receptacle	#14-16 AWG	Spade Size 1/4"	Tin Coated Brass
007813	60212-2	"	"	"	"
007814	35244	Butt-Splice Plasti-Grip	#14-16 AWG	~	Tin Coated Copper
007865	34136	Parallel Splice Plasti-Grip	#10-12 AWG	~	"
007877	31907	PIDG Ring Tongue	#14-16 AWG	5/16"	"

NOTE: Wiring loom should be used around wires to provide protection from abrasion and possible flying debris. Use loom to harness wires if possible. Where loom terminates with wire (or wires in a harness) seal off with electrical tape or shrink tubing. (See below)

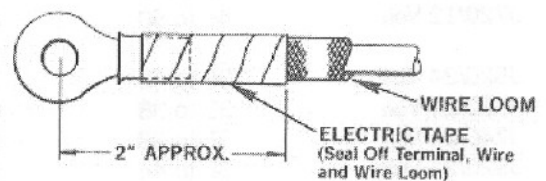
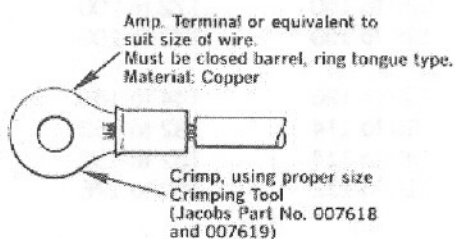

Typical wire ending when replacing damaged wires or corroded terminals.

NOTE: After replacing terminal to its proper location, torque nuts per Table 2, page 15 and then apply Loctite #290. Coat all terminals and nuts on retarder ONLY with KOPR - SHIELD® From Thomas & Betts Corp. for electrical connections. All wire lengths should be long enough as not to cause any tension on connections.



**DO NOT ROUTE WIRES ADJACENT TO FUEL, AIR OR HYDRAULIC LINES.
USE INSULATED CLAMPS AND TIES WHERE NECESSARY TO BUNDLE WIRES,
AT LEAST EVERY 18" APART.**

Fuses:

FUSE between master switch and hand or foot control is a 6 amp. fuse, replace as required.

MAIN FUSE between power source and contactor box are listed below, replace as required.

(See Table 2, Page 15 for Torque Specifications)

MODEL	VOLTS	JACOBS FUSE PART NO.	AMP. RATING
300	12	008714	225
320	12	008713	275
500	12	008712	200
520	12	008714	225
720	12	008714	225
520	24	008712	200
720	24	008712	200
740	24	008712	200
920	24	008712	200

Procedure VI

Checking Coil Amperage Draw

Install a 0-300A ammeter into the circuit to (+) terminal of Contactor Box. Start engine, run at approximately 1000 rpm, switch on retarder and record current and voltage at terminal (+) of contactor box for each coil retarding position. See Table 1 for correct values for each position for each model number.

Table 1
Electrical Requirements

@ 20°C (68°F)

MODEL NO.	POSITION #1 AMPS.	POSITION #2 AMPS.	POSITION #3 AMPS.	POSITION #4 AMPS.
J300/12 Vp/lt	43 to 50	86 to 100	129 to 150	172 to 200
J320/12 Volt	56 to 64	112 to 128	168 to 192	224 to 256
J500/12 Volt	36 to 41	72 to 82	108 to 123	144 to 164
J520/12 Volt	43 to 50	86 to 100	129 to 150	172 to 200
J720/12 Volt	43 to 50	86 to 100	129 to 150	172 to 200
J520/24 Volt	36 to 42	72 to 84	108 to 126	144 to 168
J720/24 Volt	33 to 38	66 to 76	99 to 114	132 to 152
J740/24 Volt	33 to 38	66 to 76	99 to 114	132 to 152
J920/24 Volt	38 to 44	76 to 88	114 to 132	152 to 176

NOTE: Test should be performed as fast as possible to avoid coil heating.

IF TESTS DO NOT MEET TABLE 1 REQUIREMENTS CONSULT YOUR DISTRIBUTOR.

Procedure VII Checking Air Gap

Check air gap at each pole plate using a feeler gauge. Below is a table for each model and its specific air gap.

MODEL NO.	AIR GAP ±.004 in. (±.10 mm)
J 300	.035 in. (.900 mm)
J 320	.035 in. (.900 mm)
J 500	.043 in. (1.10 mm)
J 520	.043 in. (1.10 mm)
J 720	.055 in. (1.39 mm)
J 740	.055 in. (1.39 mm)
J 920	.055 in. (1.39 mm)

If air gap is not to specifications, consult your distributor.

Section V Table 2 Torque Specifications

LOCATION	JACOBS PART NO.	BOLT OR NUT SIZE	TORQUE LB./FT./N*m	REMARKS
Retarder Mtg. Bolts	004313	14 x 2 mm	80-85/108-115	Class 5 Only
Rubber Mount Bolts Model 300 & 320	004315	8 x 1.25 mm	35-45/48-61	Class 5 Only
Mtg. Bolts for Rubber Mounts	004312	18 mm	75-85/102-115	Class 5 Only
Flange Bolts Class 8	008770	3/8"	45-50/61-68	1600 & 1700 Flange
	008777	3/8"	45-50/61-68	1800 Flange
	004421	7/16"	75-80/102-108	1400 Flange
	005627	1/2"	80-85/108-115	1500 Flange
Angle Bracket Bolts	—	1/2"	80-85/108-115	Class 5 Bolt
		5/8"	95-105/128-130	2" Long
Contactor Box & Retarder Terminal Nuts	004845	4 mm	10-15 lb.in./1.13-1.70	After Torquing Apply Loctite #290
	004741	6 mm	20-25 lb.in./2.26-2.83	
	004743	8 mm	40-50 lb.in./4.52-5.65	
	004733	5 mm	10-20 lb.in./1.13-2.26	
Alternator, Duvac, Isolator, Terminal Nuts	—	TORQUE PER MANUFACTURER'S RECOMMENDATIONS		After Torquing Apply Loctite #290
Fuse Block for Main Fuse Nuts	008715	5/16"	22-26/30-35	Loctite #290 or equivalent
Nuts for Terminal Block Caps on Retarder	004595	5 mm	4-6 lb.in./ .45-.68	Loctite #290 or equivalent

SECTION VI

Jacobs Electric Retarder Trouble-shooting And Schematics



BE CAREFUL — HIGH AMPERAGE SYSTEM

If the unit fails to operate properly, the master "ON-OFF" switch should be shut off until the unit can be inspected. Failure of Jake "ER"® can usually be traced to the electrical system. As in all trouble-shooting procedure, always check the simple things first. If the following simple steps do not isolate the problem, then consult a Jacobs Electric Retarder Distributor.

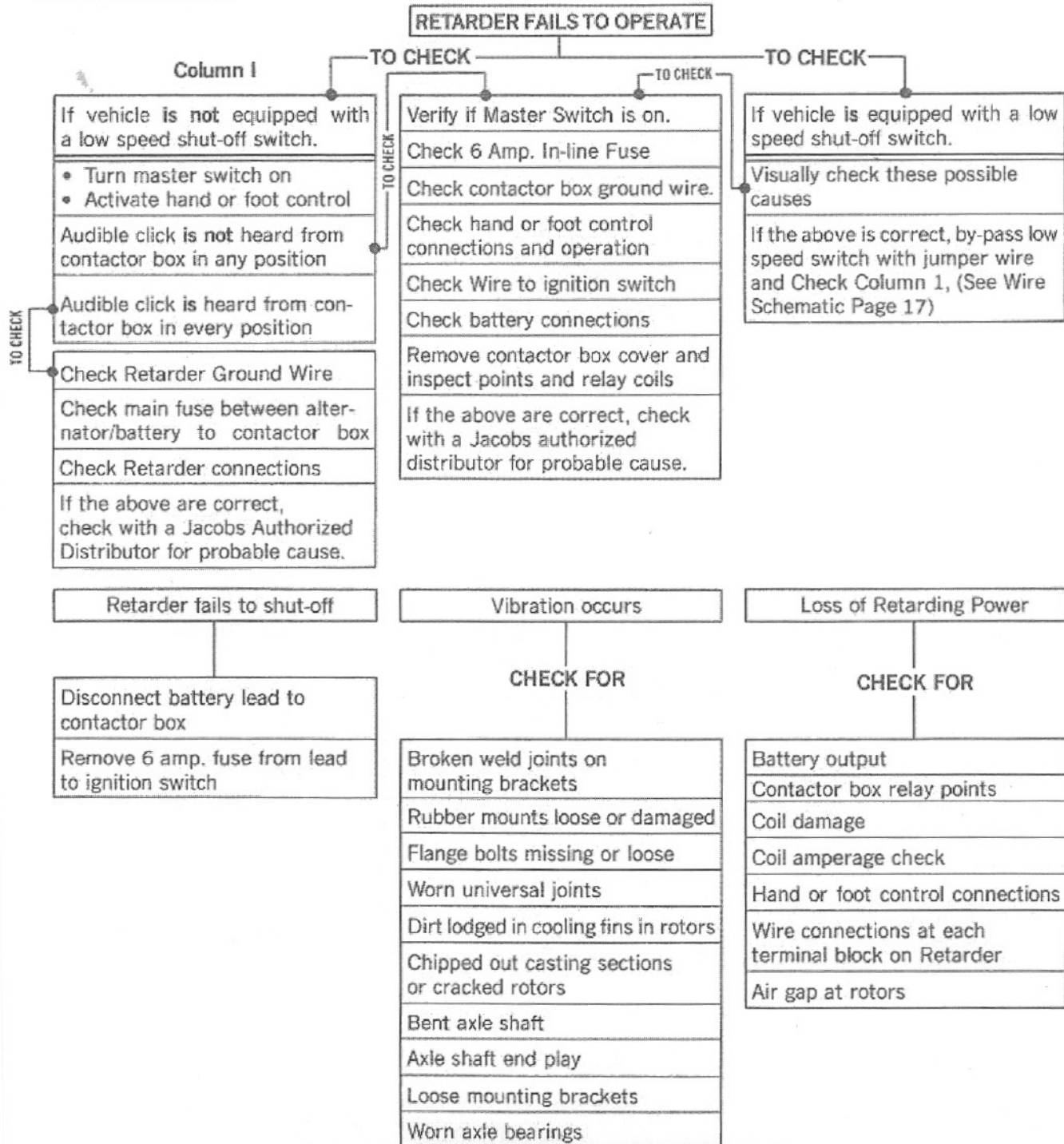

Wiring Schematics

For Low Speed Shut-off Switch (By-pass)

Illustrated below are several methods of by-passing the low speed shut-off switch for periodic maintenance check on Electric Retarder's electrical components.

Using electrical clips and #14 awg. wire, pierce insulation on wires or connect to terminals as shown below.

NOTE: If wire insulation is pierced, wrap pierced area with electrical tape.

BE CAREFUL NOT TO GROUND JUMPERS TO SPEED SENSOR HOUSING OR 6 AMP FUSE WILL SHORT OUT.

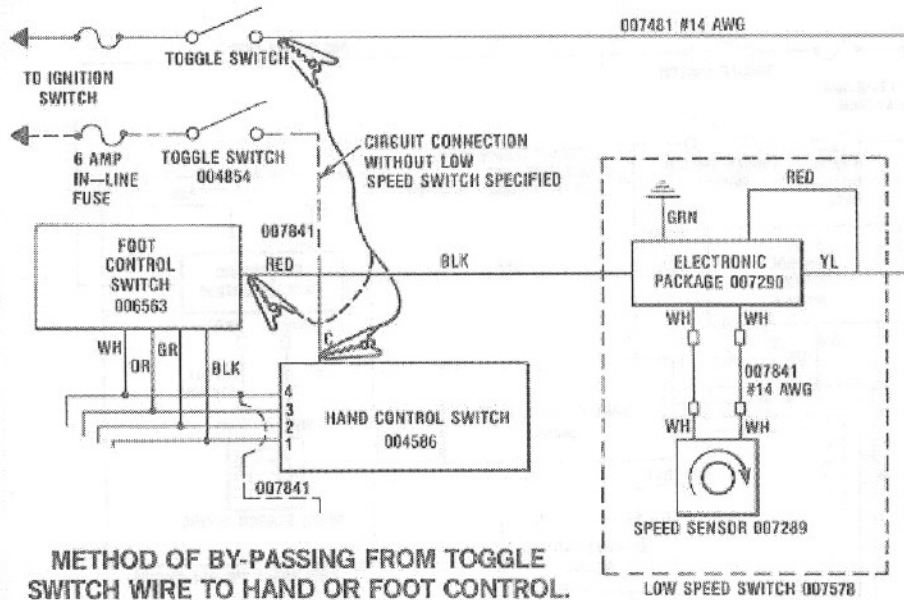

METHOD OF BY-PASSING FROM TOGGLE SWITCH WIRE TO HAND OR FOOT CONTROL.

METHOD OF BY-PASSING AT THE SPEED SWITCH

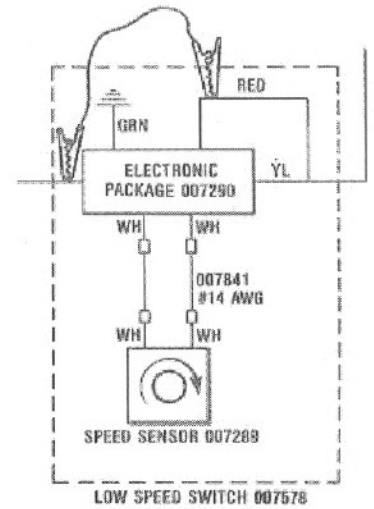

WIRING SCHEMATIC FOR 24 VOLT RETARDER ON A *12 VOLT OR **12/24 VOLT VEHICLE

- * THIS WILL REQUIRE CHANGE OF STARTER MOTOR FROM 12 VOLT TO 24 VOLT
- ** REMOVE SERIES PARALLEL SWITCH. (REPLACE WITH DUVAC®/SYKLER®)
- (NEGATIVE GROUND ONLY)

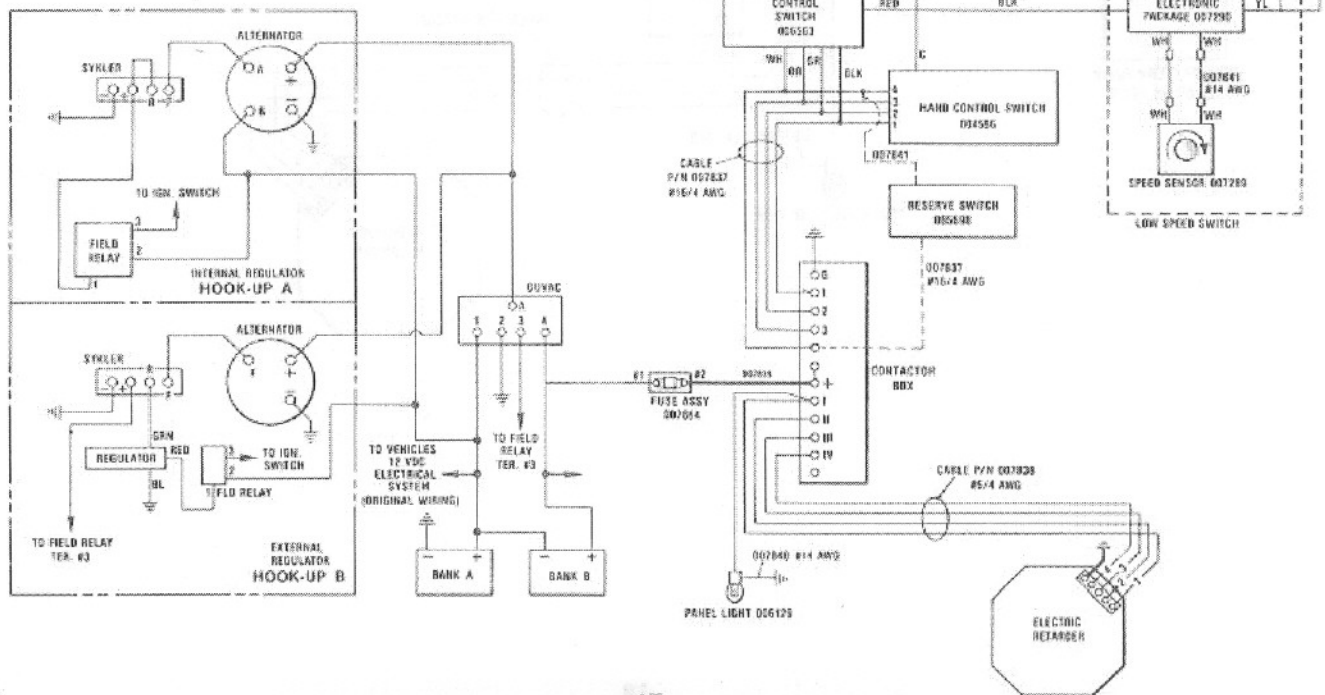

WIRING SCHEMATIC FOR 12 OR 24 VOLT RETARDER WITH INDEPENDENT ALTERNATOR & BATTERY BANK (NEGATIVE GROUND ONLY)

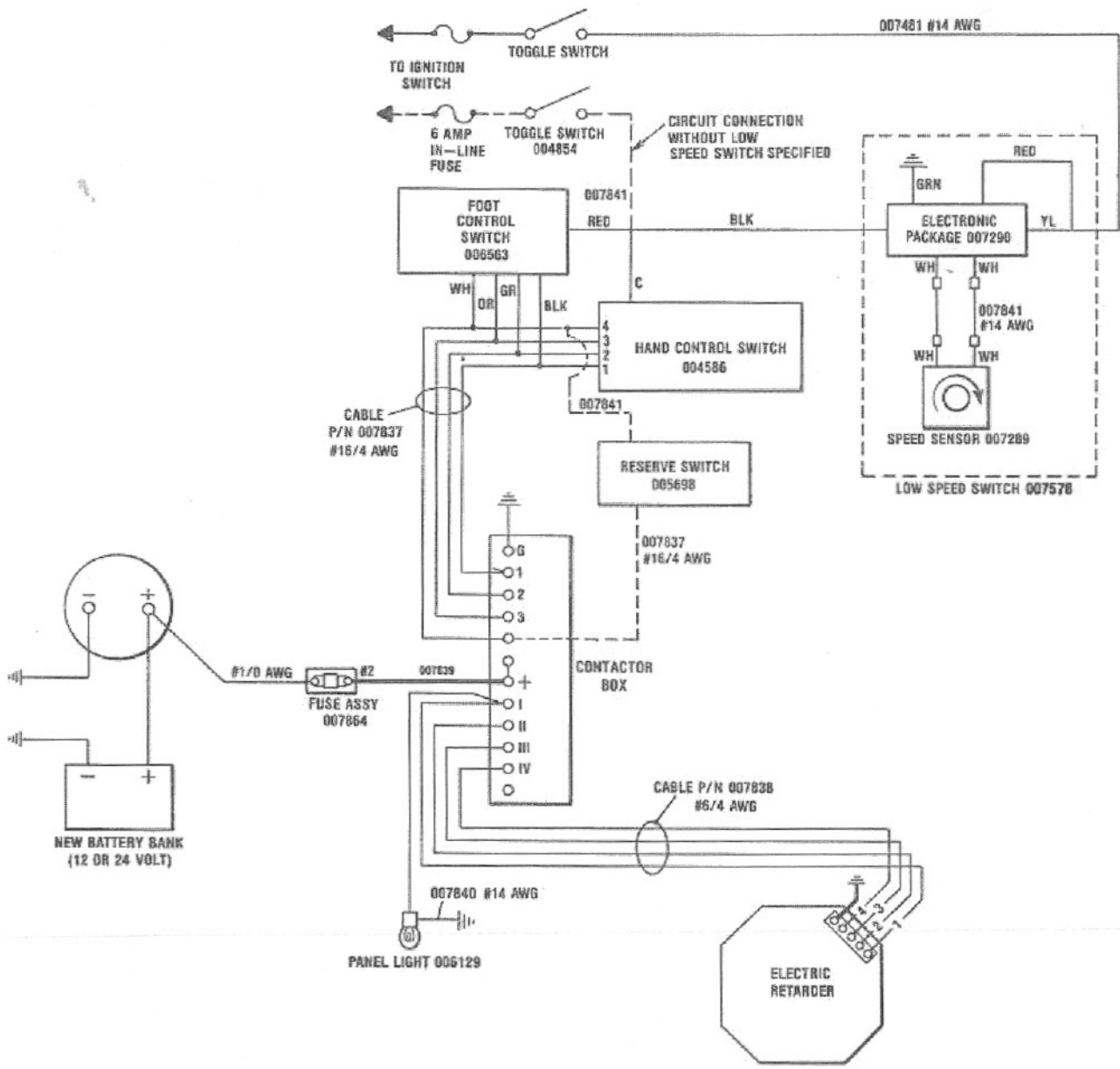

WIRING SCHEMATIC FOR 12 VOLT RETARDER ON A 12 VOLT VEHICLE OR 24 VOLT RETARDER ON A 24 VOLT VEHICLE

* WILL REQUIRE ADDITIONAL BATTERIES IN VEHICLE BATTERY BANK TO PROVIDE REQUIRED CAPACITY. (NEGATIVE GROUND ONLY)

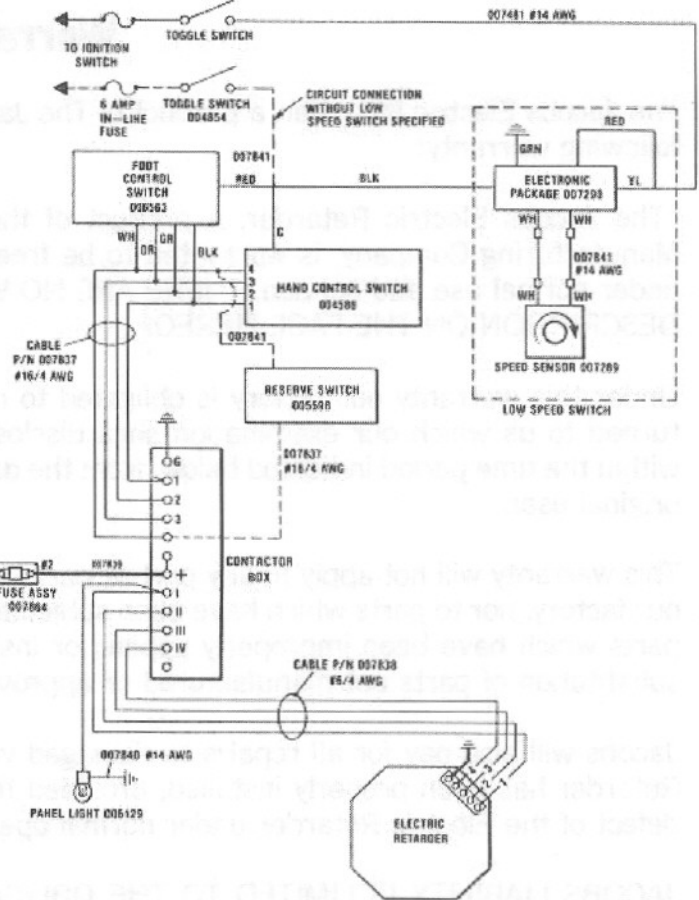
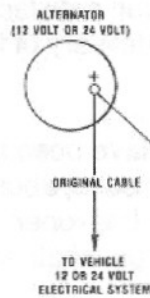

WIRING SCHEMATIC FOR 12 OR 24 VOLT RETARDER ON A 12 OR 24 VOLT* VEHICLE

*REQUIRES USE OF ISOLATOR AND ADDITIONAL BATTERY (NEGATIVE GROUND ONLY)

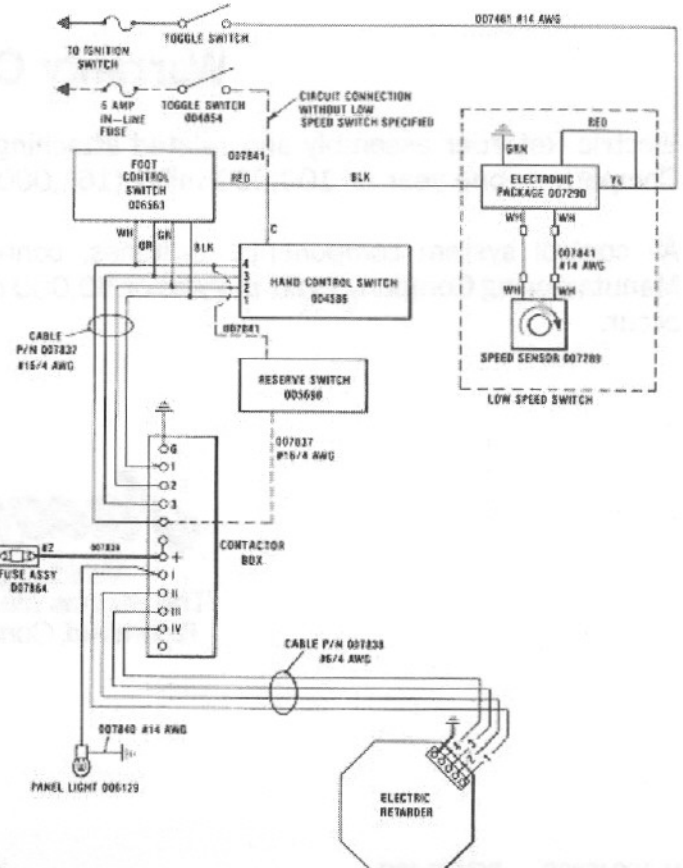
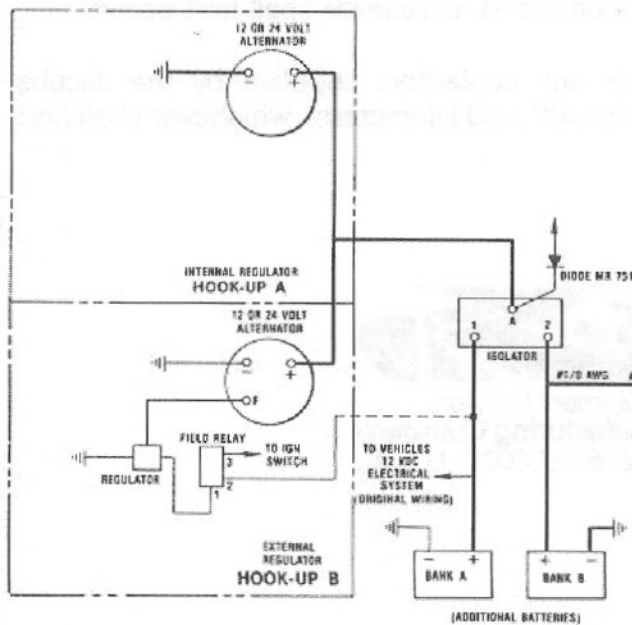

Warranty

The Jacobs Electric Retarder, a product of The Jacobs Manufacturing Company, is sold with the following warranty:

"The Jacobs Electric Retarder, a product of the Vehicle Equipment Division of The Jacobs Manufacturing Company, is warranted to be free of any defects in construction and operation under normal use and service. THERE ARE NO WARRANTIES WHICH EXTEND BEYOND THE DESCRIPTION ON THE FACE HEREOF.

Under this warranty our factory is obligated to replace, without charge, any part or parts returned to us which our examination shall disclose to our satisfaction to have been defective, within the time period indicated below, from the date of delivery of the product in question to the original user.

This warranty will not apply to any part or parts which have been altered or repaired outside of our factory, nor to parts which have been subjected to misuse, abuse, neglect or accident, nor to parts which have been improperly applied or installed. Improper installation or application, or substitution of parts not manufactured or approved by us, shall void this warranty.

Jacobs will also pay for all repairs to damaged vehicle components in which a Jacobs Electric Retarder has been properly installed, provided the damage is shown to be a direct result of a defect of the Electric Retarder under normal operation.

JACOBS LIABILITY IS LIMITED TO THE OBLIGATIONS SET FORTH HEREIN, AND JACOBS SHALL NOT BE LIABLE FOR ANY SPECIAL, INDIRECT OR CONSEQUENTIAL DAMAGES."

Warranty Coverage:

Electric Retarder assembly and related attaching parts supplied by the Jacobs Manufacturing Company — one year or 100,000 miles (161,000 kilometers), whichever shall first occur.

All control system components, switches, controls and contactors supplied by the Jacobs Manufacturing Company — six months or 50,000 miles (80,500 kilometers), whichever shall first occur.

Jacobs®
Vehicle Equipment Division
The Jacobs Manufacturing Company
Bloomfield, Connecticut 06002 U.S.A.