

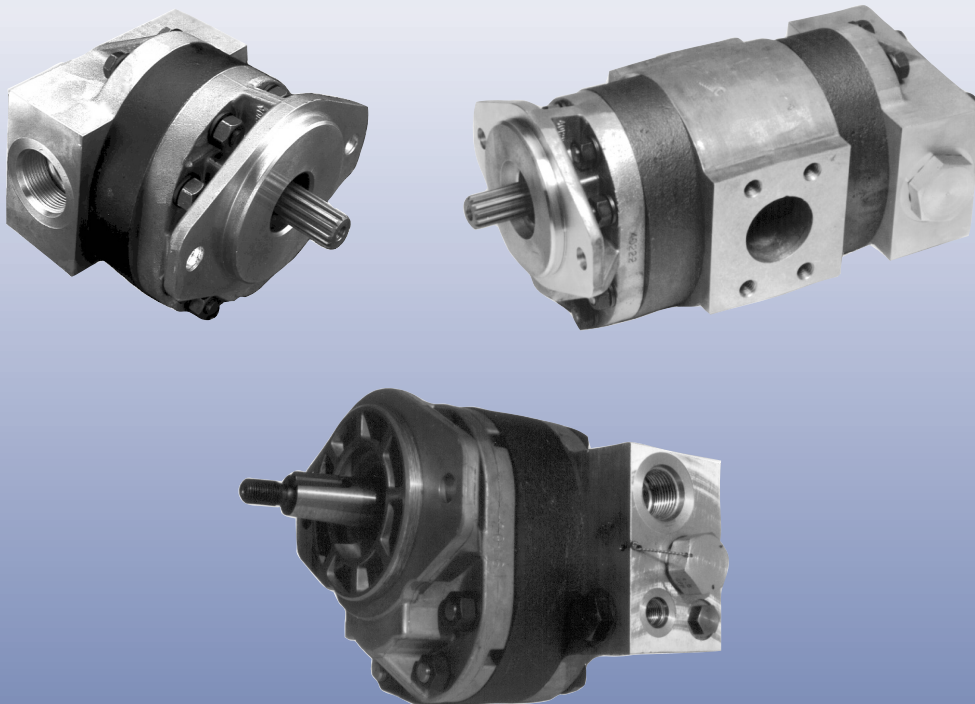









CP Series 180



Gear Pumps

Technical Information

Pumps		Motors	
	<p>B Series Pumps Combination 2/4 Bolt Mounting 4F17 or "AA" 9 models 1.80-12.13 cm³ (0.11-0.74 in³) Speeds to 3500 rpm Pressures to 240 bar (3500 psi)</p>		<p>B Series Bidirectional Motors Combination 2/4 Bolt Mounting 4F17 or "AA" 8 models 1.80-9.67 cm³ (0.11-0.59 in³) Speeds to 5000 rpm Pressures to 172 bar (2500 psi)</p>
	<p>YB Series Pumps Combination 2/4 Bolt Mounting 4F17 or "AA" 6 models 2.39-12.0 cm³ (0.146-0.73 in³) Speeds to 4000 rpm Pressures to 172 bar (2500 psi) Internal and externally drained relief valves and output checks</p>		<p>MYB Series Unidirectional Motors Combination 2/4 Bolt Mounting 4F17 or "AA" 4 models 4.8-12.00 cm³ (0.29-0.73 in³) Speeds to 5000 rpm Pressures to 172 bar (2500 psi)</p>
	<p>YC Series Pumps SAE "A" 2-Bolt Mounting 6 models 9.5-31.8 cm³ (0.58-1.94 in³) Speeds to 3000 rpm Pressures to 172 bar (2500 psi) Priority Flow Divider Covers</p>		<p>MYC Series Unidirectional Motors SAE "A" 2 & 4-Bolt Mounting 6 models 2.39-12.0 cm³ (0.146-0.73 in³) Speeds to 5000 rpm Pressures to 172 bar (2500 psi)</p>
	<p>CP180 Pumps SAE "B" Flanges & Shafts 11 models 31.79-95.7 cm³ (1.94-5.38 in³) Speeds to 3200 rpm Pressures to 310 bar (4500 psi) Priority Flow Divider Covers</p>		
	<p>CP222 Pumps SAE "C" 2 & 4-Bolt Flanges & Shafts 7 models 64.8-162.0 cm³ (3.95-9.89 in³) Speeds to 3000 rpm Pressures to 275 bar (4000 psi)</p>		

CP 180 Gear Pump Features

- World class sales and service is part of the package for every QCC gear product customer.
- Proven brand name reliability and experience in gear products for mobile and industrial applications.
- System pressures to 4500 psi (310 bar) and speeds to 3,000 rpm allow high performance in system design.
- Pressure balanced design for high efficiency and long life.
- Low cost design and manufacturing for the requirements of fixed displacement systems.
- Variety of flexible installation options available:
 - SAE "B" flanges, shafts and ports
 - Convenient side or rear porting options
 - Auxiliary through drive SAE mounting pads
 - Integral relief valve, priority flow control, and priority flow divider covers
 - High temperature viton seals optional
 - Multiple pump configurations

The Family of QCC Gear Pumps and Motors

Quick Reference - Displacement/Model

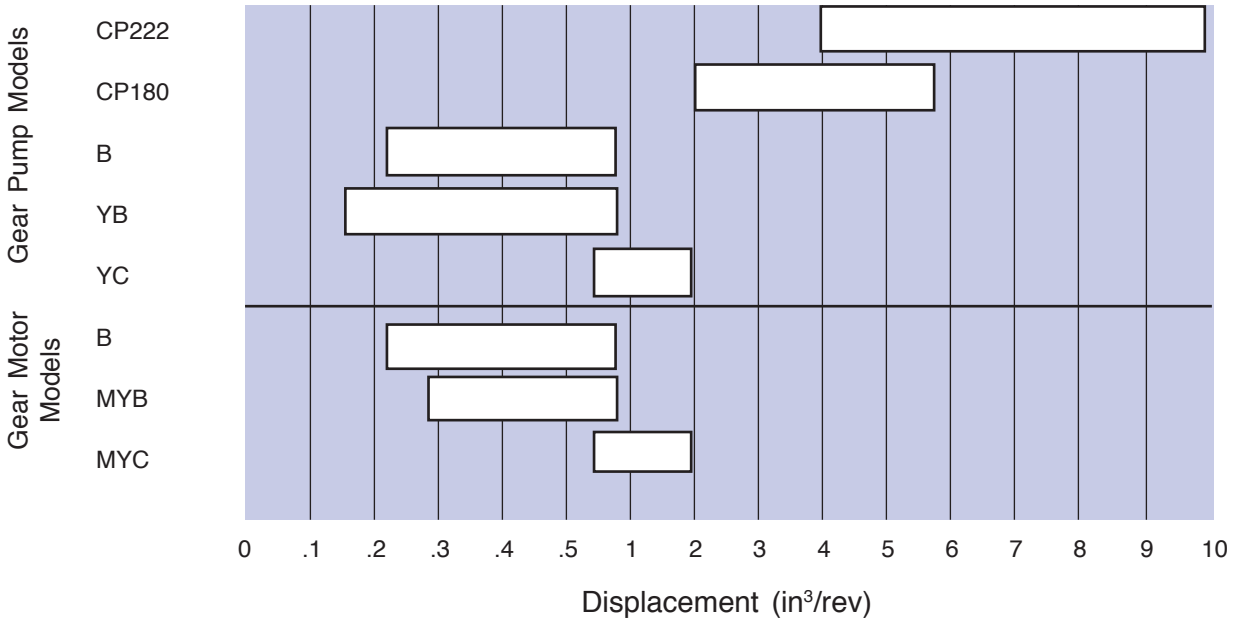

Table of Contents

CP180 Gear Pump Features 3

The Family of QCC Gear Pumps and Motors 4

Technical Features..... 5

Pump Sizing Calculations..... 9

CP 180 Single Gear Pumps 10

CP 180 Gear Pumps with Priority Flow Divider (PFD) 10

CP 180 Gear Pump Specifications..... 11

CP 180 Single Gear Pump Dimensions..... 18

CP 180 Single Gear Pump Cover and Shaft Options..... 19

CP 180 Priority Flow Divider Pump Dimensions and Options..... 20

CP 180 Priority Flow Divider Pump Dimensions and Options, Continued 21

CPB (CP 180 Single, SAE "B" 2 Bolt Flange, Side Ports) Modular Ordering Code 22

CPC (CP 180 Single, SAE "B" 2 Bolt Flange, Rear Ports) Modular Ordering Code 23

CPD (CP 180 Single, SAE "B" 4 Bolt Flange, Side Ports) Modular Ordering Code 24

CPJ (CP 180 Single, SAE "B" 2 Bolt Flange and PFD Cover) Modular Ordering Code..... 25

CP 180 Tandem Gear Pumps..... 26

CP 180 Tandem Gear Pump Dimensions 27

CPE (CP 180 Tandem, SAE "B" 2-Bolt Flange, Side Ports) Modular Ordering Code..... 28

CPE (CP 180 Tandem, SAE "B" 2-Bolt Flange, Side Ports) Modular Ordering Code, cont. 29

CPF (CP 180 Tandem, SAE "B" 2 Bolt Flange, Rear Ports) Modular Ordering Code..... 30

CPF (CP 180 Tandem, SAE "B" 2 Bolt Flange, Rear Ports) Modular Ordering Code, cont. 31

CPG (CP 180 Tandem, SAE "B" 4 Bolt Flange, Side Ports), Modular Ordering Code..... 32

CPG (CP 180 Tandem, SAE "B" 4 Bolt Flange, Side Ports), Modular Ordering Code, cont. 33

Technical Features

DESIGN

QCC CP Series gear pumps utilize an external spur gear, positive displacement, and pressure balanced design, providing superior efficiency. These "heavy duty cycle" pumps are three-piece construction utilizing an aluminum flange and cover with Compacted Graphite Iron gear housings. This design offers superior resistance to contamination and excellent strength to survive in the harsh "construction type" environments but are light in weight. Oversized journal bearings (DU) are utilized to provide maximum life. By design, the gears of this pump on initial running track into the gear housing and create their own radial tip seal for high volumetric efficiency.

Figure 1:

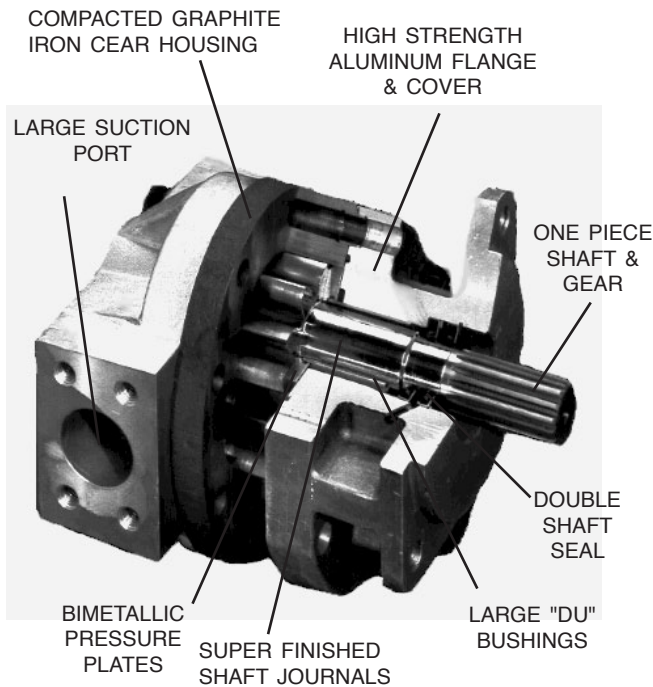

(2) The gears are directed to "track in" at a zone further up the circle from the inlet than in a conventional pump. This "Delayed Track" increases low speed efficiency by providing a better low pressure to high pressure area ratio than conventional designs.

Figure 2:

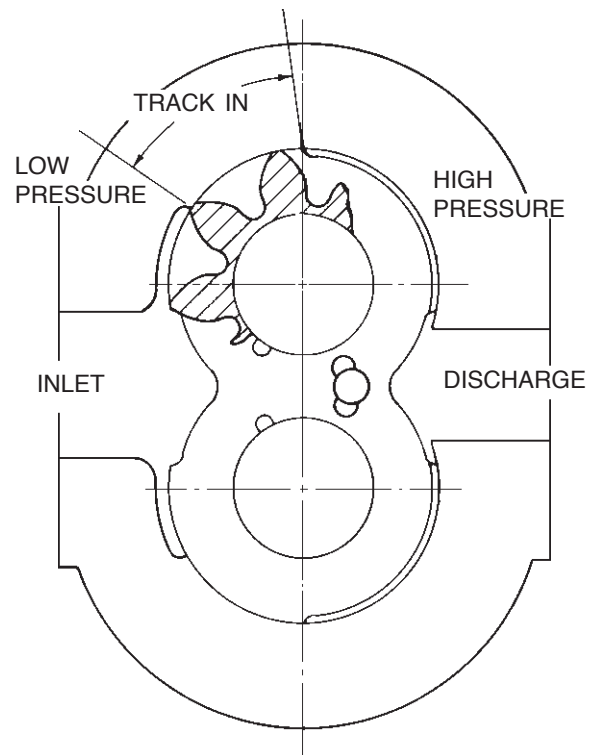

DELAYED INLET

All QCC CP Series pumps are manufactured to maximize efficiency and to enhance performance. The "Delayed Inlet" feature provides a number of advantages.

(1) Because more gear teeth are exposed to the inlet, the dwell time to fill the gear teeth is improved, thus allowing the pump to perform better at low temperatures and with more viscous fluids.

LEAK PROTECTION

Various seals are available to meet specific applications. Standard are dual Buna seals to prevent leakage and migration of fluids from the hydraulic circuit to the gear box.

An optional weep hole between the seals is available to further protect the gear box and show leakage if any should occur. Section seal rings are exposed to inlet to reduce the risk of external leakage.

Technical Features, Continued

INLET OIL BUSHING LUBRICATION

The design of the CP Series is such that cooler inlet oil is routed to "flood" the DU Bushings with oil. This principle eliminates the need to force high pressure leakage to the journals. This allows the pump to run cooler, with higher volumetric efficiency.

THERMAL EXPANSION OF ALUMINUM MEMBERS THERMAL EXPANSION OF IRON BODY

As the oil temperature increases and oil viscosity goes down, the CP Series pump changes its tip clearance to compensate for this increased leakage. By using dissimilar materials (i.e., aluminum covers and iron gear housings), the difference in their coefficients of expansion causes the pump components to move in a manner which maintains volumetric efficiency as temperature increases.

LESS DEBRIS IN THE EVENT OF BEARING FAILURE

In the unlikely event of a bearing failure the CP pump offers, by design, release of less downstream contaminant to your systems than conventional pumps. Because the "track" is essentially tangent to the induced load, in the event of a failure, the gear (idler) tends to move into the pre-cut "delayed inlet slot." Failure detection is the same as a conventional pump but the volume of debris ingested is significantly less.

Figure 3:
The DU® Bearing

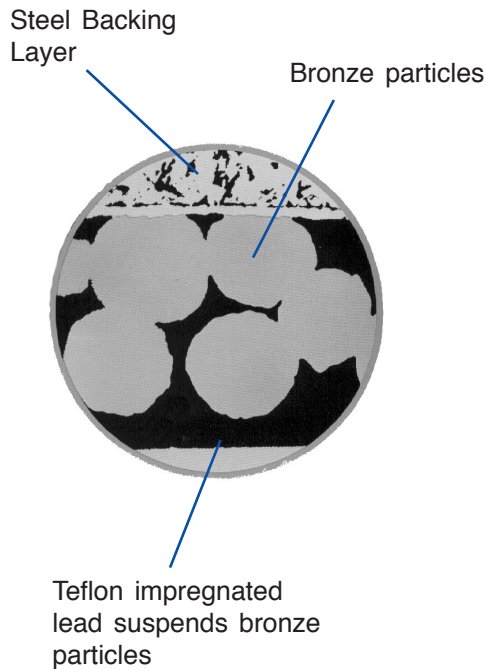
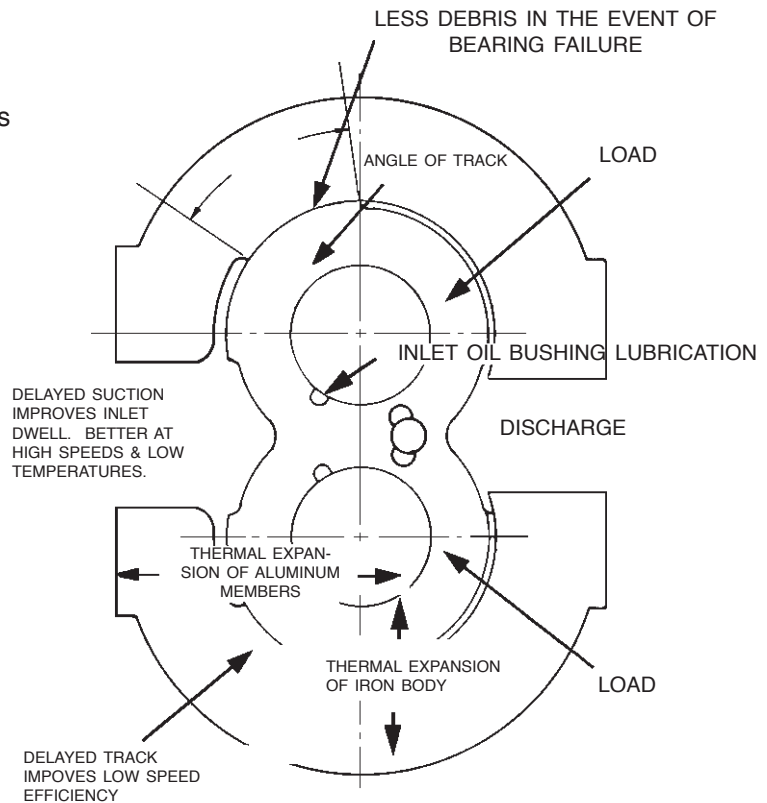

Figure 4:



DU® is a trademark of the Garlock Bearing Company

Technical Features, Continued

DRIVE CONDITIONS

Most QCC gear products are available SAE standard spline or straight keyed drive shafts for direct or indirect drive applications. A three piece coupling is the preferred method of direct drives, thereby eliminating radial and axial loading.

Rigid splines may be used providing the mounting pilot should be aligned within .002 in. (.05 mm) on center [.004 (.10 mm) TIR].

Both concentricity and angular alignment of shafts are important to pump life. Misalignment can induce heavy side loads on bearing and seals, causing premature failure.

Overhung load drives (chain, belt, or gear) are permissible. Contact QCC for assistance.

FILTRATION

A wire gauze strainer with a mesh opening of 90 micron (170 mesh) should be incorporated into the pump inlet line from the reservoir. The size of the suction strainer is determined by the limiting suction condition and must be correctly sized and cleaned on a regular basis to prevent cavitation.

A full flow 10 micron filter should be used in the system return line to trap all contaminants before they enter the reservoir.

Since the filter must be changed at regular intervals, the filter housing should be located in an accessible area.

OPERATING TEMPERATURES

With Buna seals and normal operating conditions, the system temperature should not exceed 180° F (82°C) except for short periods to 200° F (93° C).

With optional Viton elastomers, the system may be operated at continuous temperatures up to 225° F (107° C) without damage to the pump.

CAUTION: Operation in excess of 225° F may cause external leakage or premature unit failure.

FLUIDS

A mineral based fluid is recommended with additives to resist corrosion, oxidation and foaming. The oil should have the maximum viscosity commensurate with system pressure drop and pump suction levels. The viscosity at any running condition must be between 45 SSU minimum and 250 SSU maximum continuous.

Since the fluid used serves as a system lubricant, as well as transmitting power, careful selection of the fluid is important for proper operation of the unit and satisfactory life of the pump and components.

SUCTION

For maximum pump life, the inlet vacuum should not exceed 4 inches (100 mm) Hg at the pump inlet. For cold start conditions, vacuum up to 12 inches (300 mm) Hg. is acceptable for short durations.

Both cavitation and the possibility of aeration increase with higher inlet vacuum. In addition, oil film lubrication is disrupted by high inlet vacuum. Both factors, either singularly or combined, may contribute to a decrease in pump life.

CAUTION: Continuous operation at vacuums in excess of 4 inches Hg. may cause premature unit failure.

MAXIMUM SPEED

Maximum speed is limited by gear tooth filling and surface speeds centrifugal gear teeth filling. Unless otherwise specified, maximum rated pump speeds listed in this manual are based on operation at sea level with SAE oil having a viscosity of 120 SSU at 122° (50°C). Speed limits for a particular application depend on inlet pressure and oil viscosity. Consult QCC for operation outside these limits.

MINIMUM SPEED

Minimum recommended operating speed at 2500 psi is 600 RPM. Minimum speed is limited by volumetric efficiency. If lower than recommended starting or operating speeds are required, contact QCC for assistance.

Technical Features, Continued

For motors, minimum speeds listed are for continuous operation at rated pressure. Motors may be started from zero speed on drives where torque typically increases with speed. Repeated starts under high load conditions are not recommended. No load start up pressures range from 300 to 600 PSI (20.7 to 41.4 BAR).

INPUT TORQUE RATINGS

The individual product dimensional configurations in this catalog list the maximum continuous input torques for various shaft options.

When applying pumps in tandem or multiple, observe that input torque limitations must be met for each section and cumulative sections.

Always insure that the rear pump on a tandem unit does not exceed its torque rating.

CAUTION: Torques in excess of those shown may cause premature input shaft or unit failure.

MOUNTING

The pump mount/drive should be designed to minimize axial and radial loads on the shaft. When using indirect (chain, belt, or gear) drive, contact QCC to determine permissible load limits and direction of installation.

PIPING

The choice of piping size and installation should always be consistent with maintaining minimum velocity. This will reduce system noise, pressure drops and overheating, thereby adding to cost savings for both the construction and operation of the system.

Inlet piping should be designed to prevent continuous pump inlet vacuums in excess of 4 in. (100 mm) Hg. or 12 in. (300 mm) Hg. during start-up when measured at the inlet port.

RESERVOIR

The reservoir should be designed to accommodate maximum volume changes during all system operating modes and prevent aeration of the fluid as it passes through the tank. Return and inlet lines should be positioned below the reservoir low oil level and be located as far as possible from each other. A baffle plate located between the pump inlet and return line is desirable to allow the oil to deaerate before it enters the pump.

Reservoirs are normally sized for at least one-half the maximum pump flow for adequate oil deaeration.

COOLING

Depending on duty cycle and reservoir/line construction, an oil cooler may be required. This is sized based on typical power losses in the hydraulic circuit. The oil cooler is usually placed in the return line.

CAVITATION

Hydraulic oil used in the majority of systems contains about 10% dissolved air by volume. This air under certain conditions of vacuum within the system is released from the oil causing air bubbles. These air bubbles collapse if subjected to pressure, and this collapse creates erosion of the adjacent metal. Because of this, it becomes obvious that the greater the air content within the oil, or the greater the vacuum in the inlet line, the more severe will be the resultant erosion.

The main causes of over-aeration of the oil are air leaks, particularly on the inlet side of the pump, and flow line restrictions such as inadequate pipe sizes, elbow fittings and sudden changes in flow line cross sectional area. Providing these defects are avoided; pump inlet pressure and rated speed requirements are maintained; and reservoir size and location is adequate, no cavitation problems should occur with QCC pumps and motors.

Technical Features, Continued

PRESSURE PROTECTION & RATINGS

The pump, as well as other system components, has pressure limitations. Thus a relief valve must be installed in the system, preferably as close to the pump as possible, to protect it from excessive pressure. If the relief valve is set at or near the maximum pressure rating for the pump, the operating characteristics of the valve should be known so that common relief valve overshoot does not allow system pressure to exceed the pump rating. Intermittent is defined as less than 15% of the duty cycle. Peak is defined as relief valve maximum overshoot. Contact QCC for pressures above those listed.

CAUTION: Failure to install this relief valve may result in premature unit failure.

LIFE EXPECTANCY

All QCC gear pumps utilize pressure balanced journal bearings which have an oil film maintained between the gear/shaft and bearing surfaces at all times. If this oil film is sufficiently sustained through proper system maintenance and operating limits are adhered to, a high life can be expected.

NOTE: A B-10 type life expectancy number is generally associated with anti-friction bearings and does not exist for journal bearings.

Pump Sizing Calculations

Si System

$$\text{Output flow } Q_e = \frac{Vg \cdot n \cdot \eta_v}{1000} \quad \text{l/min}$$

$$\text{Input torque } M_e = \frac{Vg \cdot \Delta p}{20 \cdot \pi \cdot \eta_{mh}} \quad \text{Nm}$$

$$\text{Input Power } P = \frac{M_e \cdot n}{9550} = \frac{Q_e \cdot \Delta p}{600 \cdot \eta_t} \quad \text{kW}$$

- Vg = Displacement per revolution in cm³
- p_{HD} = High pressure, in bar
- p_{ND} = Low pressure, in bar
- Δp = p_{HD} - p_{ND} bar (System pressure)
- n = Speed rpm (min⁻¹)
- η_v = Volumetric efficiency, (%)
- η_{mh} = Mechanic - hydraulic efficiency, (%)
- η_t = Overall efficiency, (%)

English System

$$\text{Output flow } Q_e = \frac{Vg \cdot n \cdot \eta_v}{231} \quad \text{gal/min}$$

$$\text{Input torque } M_e = \frac{Vg \cdot \Delta p}{2 \cdot \pi \cdot \eta_{mh}} \quad \text{in} \cdot \text{lb}$$

$$\text{Input Power } P = \frac{M_e \cdot n}{63025} = \frac{Q_e \cdot \Delta p}{1714 \cdot \eta_t} \quad \text{HP}$$

- Vg = Displacement per revolution in in³
- p_{HD} = High pressure, in psi
- p_{ND} = Low pressure, in psi
- Δp = p_{HD} - p_{ND} psi (System pressure)
- n = Speed rpm (min⁻¹)
- η_v = Volumetric efficiency, (%)
- η_{mh} = Mechanic - hydraulic efficiency, (%)
- η_t = Overall efficiency, (%)

CP 180 Single Gear Pumps

- 11 Sizes from 2.01 to 5.84 cu.in/rev. (32.94 to 95.70 cc/rev.)
- SAE 2-Bolt "B" Mounting Flange
- SAE 4-Bolt "B" Mounting Flange
- Spline or Keyed Shaft
- SAE 4-Bolt Split Flange Side Ported, Code 61
- SAE O-Ring Boss Ports - Side and Rear
- "Nitrile" Seals - Standard, "Viton" Seals - Optional
- Auxiliary Pad Rear Cover - SAE "A" & "B" Pad Mounts
- Clockwise or Counterclockwise Rotation
- Pressure - 3600 PSI Continuous (4500 PSI Peak)
- Speeds to 3000 RPM

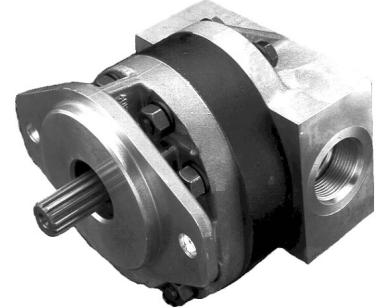

CP 180 Gear Pumps with Priority Flow Divider (PFD)

- 7 Sizes from 2.01 to 3.88 cu.in/rev. (32.94 to 63.63 cc/rev.)
- SAE 2-Bolt "B" Mounting Flange Standard
- Spline or Keyed Shaft
- SAE 4-Bolt Split Flange Side Ported, Code 61
- SAE O-Ring Boss Ports - Side and Rear
- "Nitrile" Seals - Standard, "Viton" Seals - Optional
- 7 Standard Priority Flow Settings from 2 gpm to 8 gpm*
- 5 Standard Pressure Options from 130 to 190 Bar (1885 to 2755 psi)**

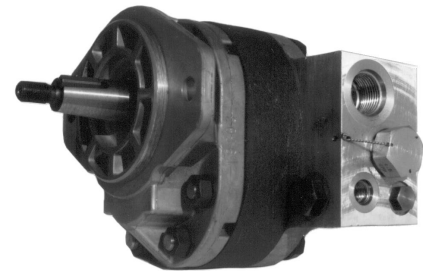

*Nominal flow setting at 30 gpm (115 L/min) maximum pump flow and auxiliary supply 1000 psi (69 Bar) greater than priority pressure.

**Nominal dead head pressure set at 1.0 gpm (3.85 L/min) flow

Shaft and Port Option Prefix Codes for the CP series:

- CPB = CP 180 Single Pump with SAE "B" 2 Bolt flange and Side Ports
- CPC = CP 180 Single Pump with SAE "B" 2 Bolt flange and Rear Ports
- CPD = CP 180 Single Pump with SAE "B" 4 Bolt flange and Side Ports
- CPE = CP 180 Tandem Pump with SAE "B" 2 Bolt flange and Side Ports
- CPF = CP 180 Tandem Pump with SAE "B" 2 Bolt flange and Rear Ports (on rear section)
- CPG = CP 180 Tandem Pump with SAE "B" 4 Bolt flange and Side Ports
- CPJ = CP 180 Priority Flow Divider Single Pump with SAE "B" 2 Bolt flange

CP 180 Gear Pump Specifications

Table 1:

CP 180	Dimension	Frame Size										
		020	023	026	030	032	035	040	045	050	055	060
Displacement	cu. in. / rev	2.01	2.24	2.54	2.92	3.14	3.40	3.88	4.37	4.85	5.36	5.84
	cc/rev	32.94	36.65	41.60	47.77	51.49	55.70	63.63	71.58	79.53	87.83	95.70
Continuous Pressure	psi	3600	3600	3600	3600	3600	3600	3600	3600	3300	3000	2700
	bar	250	250	250	250	250	250	250	250	230	210	185
	rpm	3000	3000	3000	3000	2800	2800	2800	2600	2600	2400	2400
Intermittent Pressure	psi	4000	4000	4000	4000	4000	4000	4000	4000	3650	3300	3000
	bar	275	275	275	275	275	275	275	275	255	230	210
	rpm	3000	3000	3000	3000	2800	2800	2800	2600	2600	2400	2400
Peak Pressure	psi	4500	4500	4500	4500	4500	4300	4100	4100	3800	3600	3400
	bar	310	310	310	310	310	295	280	280	260	250	235
Minimum Speed at 2500 psi	rpm	600	600	600	600	600	600	600	600	600	600	600
Weight	lbs	19.29	19.60	20.00	20.50	20.90	21.30	22.20	23.10	24.00	24.90	25.80
	kgs	8.75	8.89	9.07	9.32	9.48	9.68	10.09	10.50	10.91	11.30	11.70

Note: For applications requiring parameters beyond those listed above, contact QCC.

Table 2:

Theoretical Flow vs Speed, For Reference Only											
Frame Size	Speed	1200 RPM		1500 RPM		2000 RPM		2500 RPM		3000 RPM	
	Units	liters/min	GPM	liters/min	GPM	liters/min	GPM	liters/min	GPM	liters/min	GPM
020	Flow	10.44	39.53	13.05	49.41	17.40	65.88	21.75	82.34	26.10	98.81
023		11.64	43.98	14.55	54.98	19.39	73.30	24.24	91.63	29.09	109.95
026		13.19	49.92	16.49	62.40	21.99	83.20	27.49	104.00	32.99	124.80
030		15.17	57.32	18.96	71.66	25.28	95.54	31.60	119.43	37.92	143.31
032		16.31	61.79	20.39	77.24	27.19	102.98	33.98	128.73	40.78	154.47
035		17.66	66.84	22.08	83.55	29.44	111.40	36.80	139.25	44.16	167.10
040		20.16	76.36	25.19	95.45	33.59	127.26	41.99	159.08	50.39	190.89
045		22.70	85.90	28.38	107.37	37.84	143.16	47.29	178.95	56.75	214.74
050		25.19	95.44	31.49	119.30	41.99	159.06	52.49	198.83	62.99	238.59
055		27.84	105.40	34.81	131.75	46.41	175.67	58.01	219.59	69.61	263.50
060		30.34	114.84	37.92	143.55	50.56	191.40	63.20	239.25	75.84	287.10

CP 180 Performance Curves, (Continued)

[$\nu = 34 \text{ mm}^2/\text{s}$ (160 SUS), $\vartheta = 49^\circ \text{ C}$ (120°F)]

Figure 5:

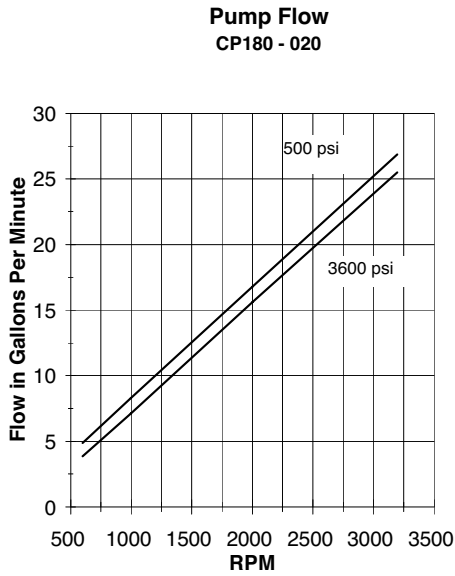

Figure 6:

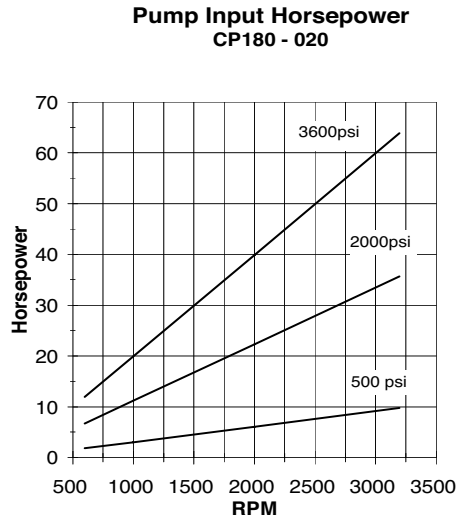

Figure 7:

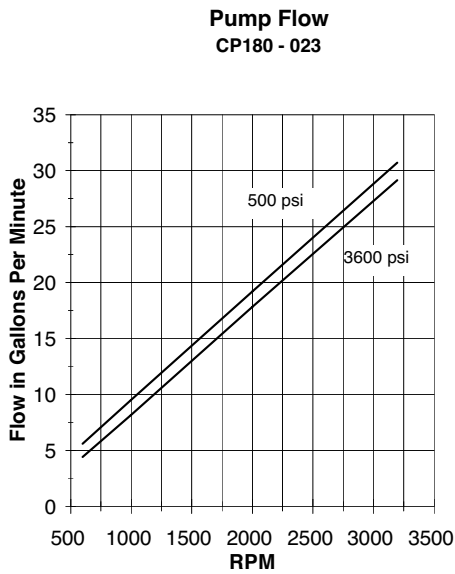
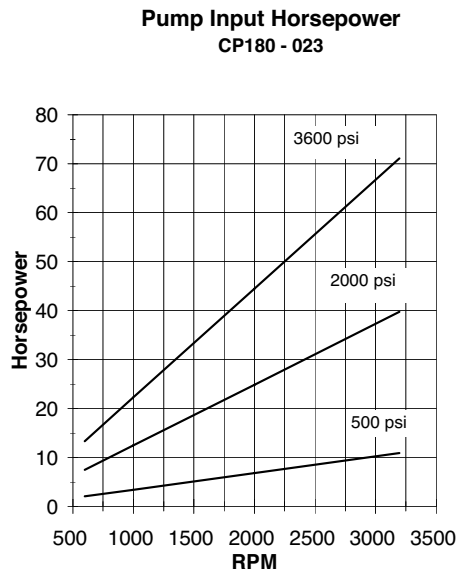

Figure 8:



CP 180 Performance Curves, (Continued)

[$v = 34 \text{ mm}^2/\text{s}$ (160 SUS), $\vartheta = 49^\circ \text{ C}$ (120°F)]

Figure 9:

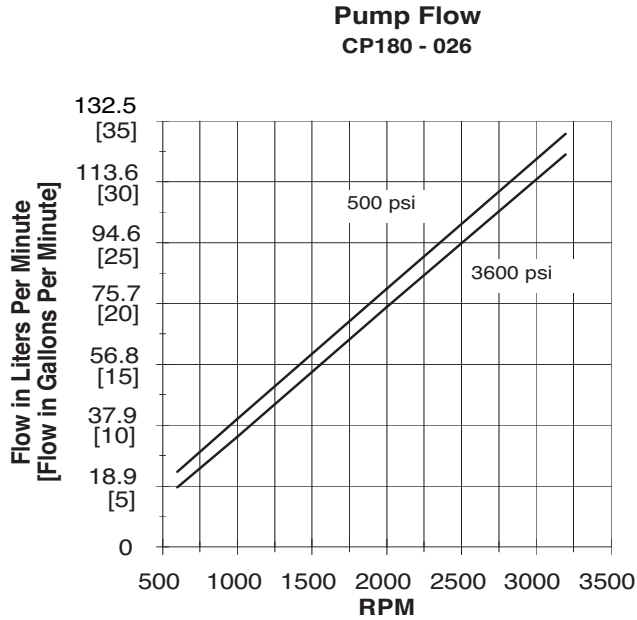

Figure 10:

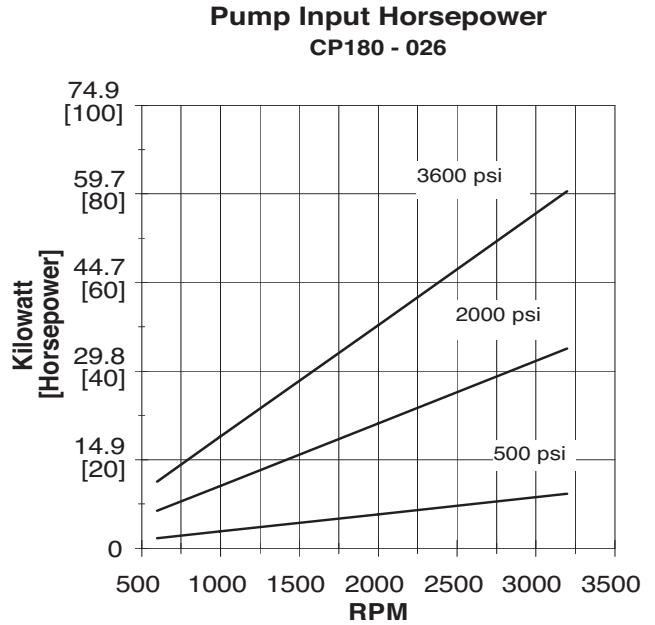

Figure 11:

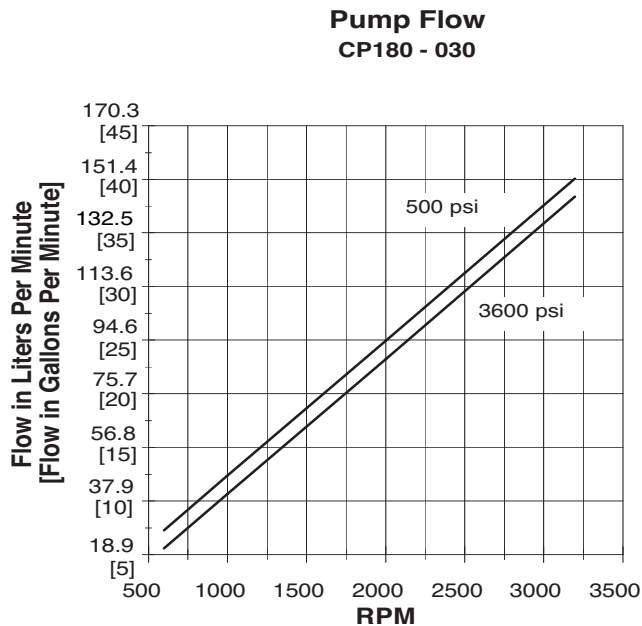
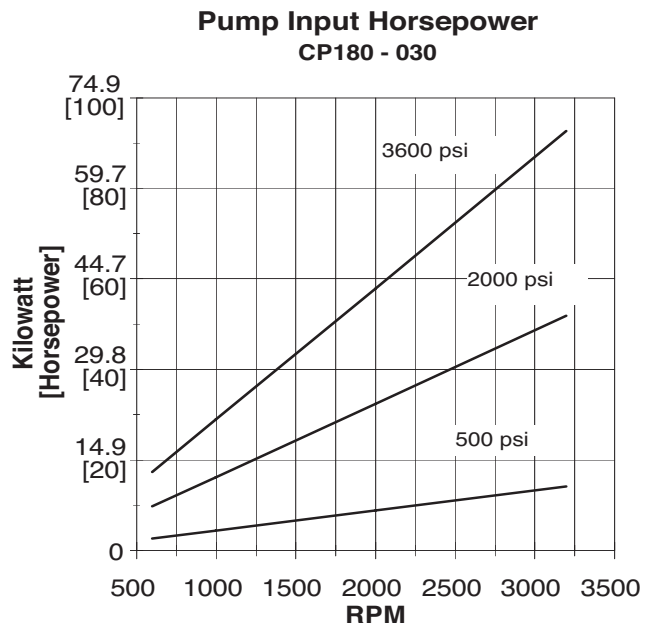

Figure 12:



CP 180 Performance Curves, (Continued)

[$\nu = 34 \text{ mm}^2/\text{s}$ (160 SUS), $\vartheta = 49^\circ \text{ C}$ (120°F)]

Figure 13:

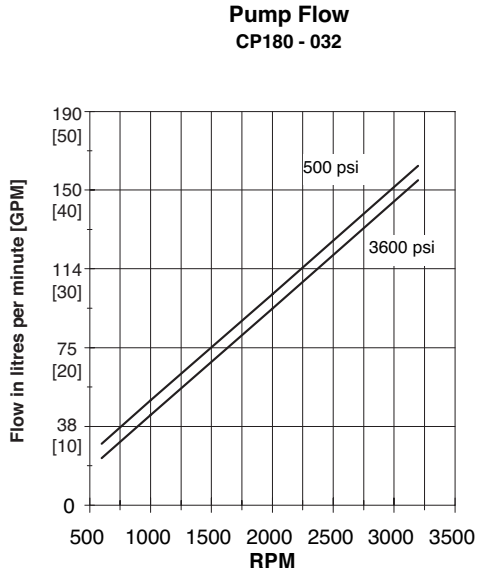

Figure 14:

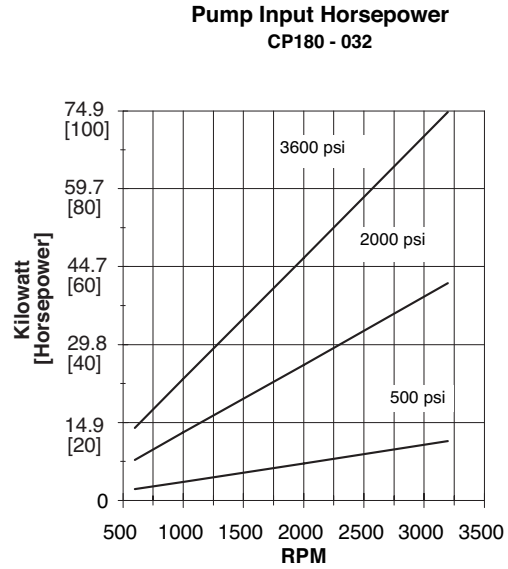

Figure 15:

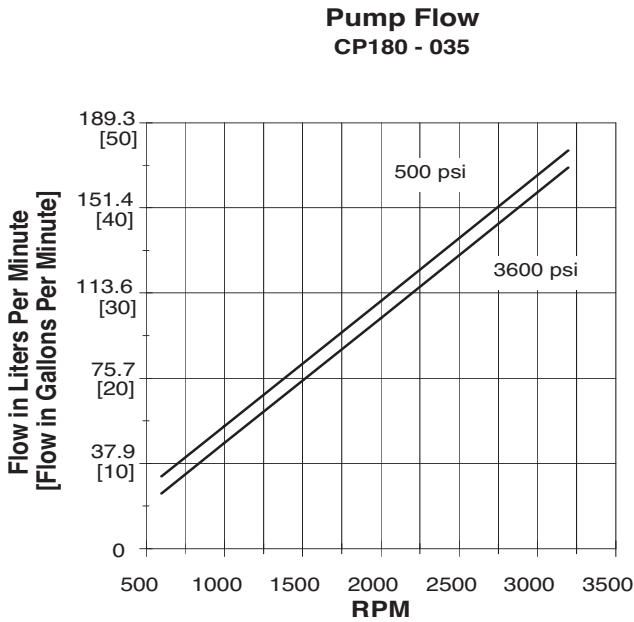
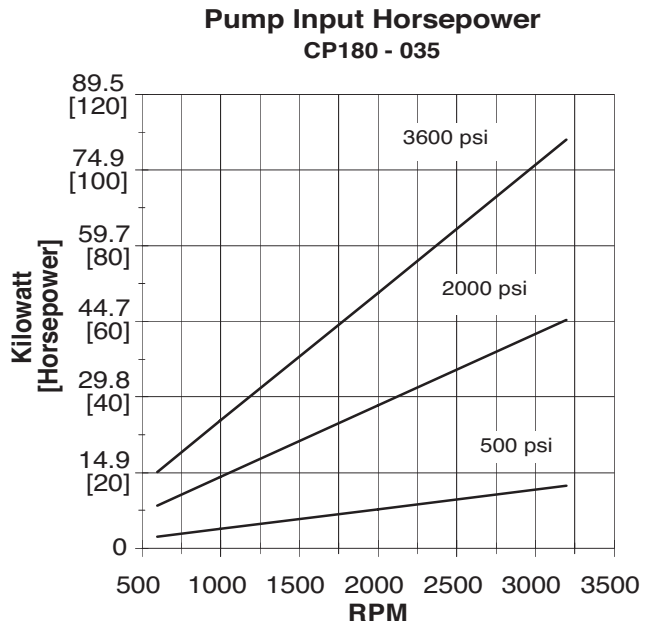

Figure 16:



CP 180 Performance Curves, (Continued)

[$v = 34 \text{ mm}^2/\text{s}$ (160 SUS), $\vartheta = 49^\circ \text{ C}$ (120°F)]

Figure 17:

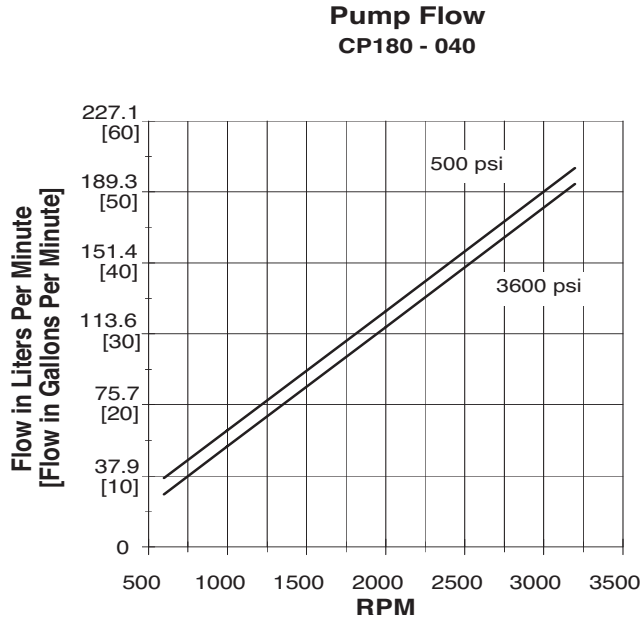

Figure 18:

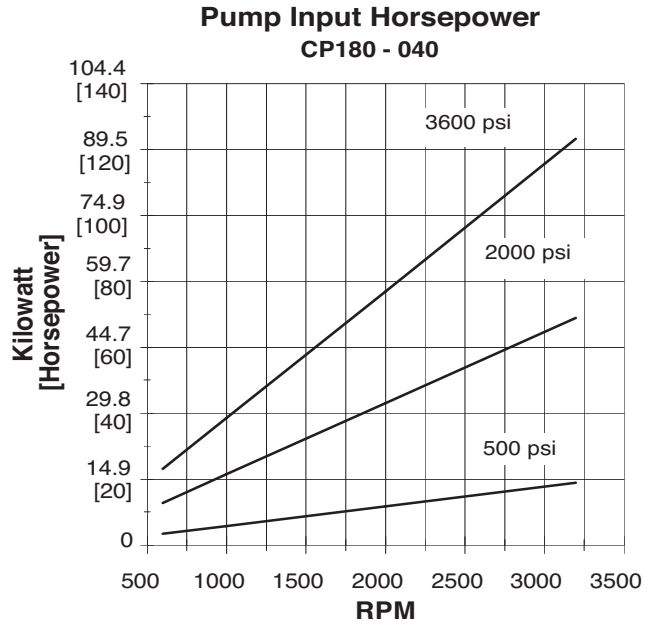

Figure 19:

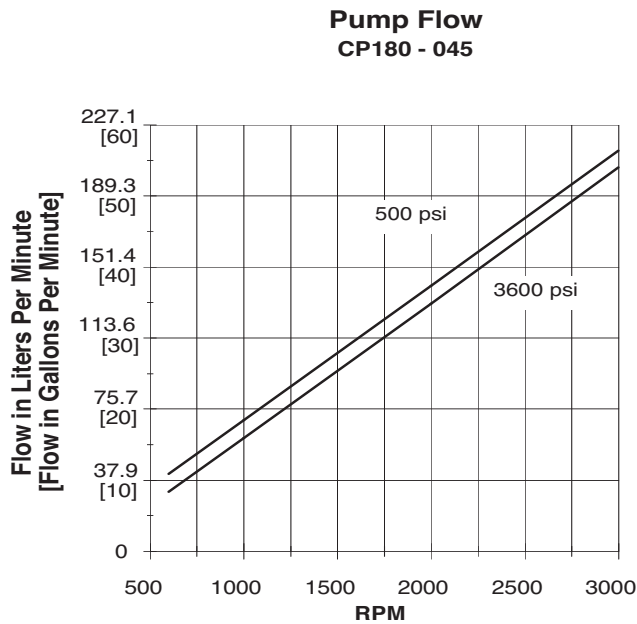
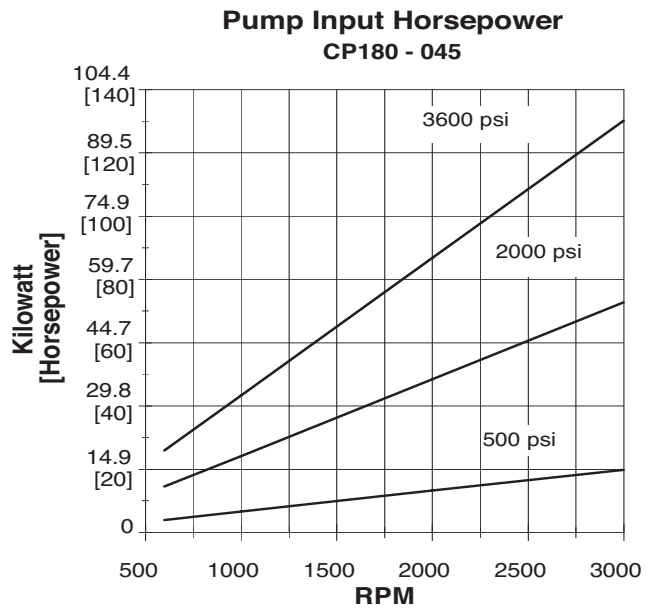

Figure 20:



CP 180 Performance Curves, (Continued)

[$\nu = 34 \text{ mm}^2/\text{s}$ (160 SUS), $\vartheta = 49^\circ \text{ C}$ (120°F)]

Figure 21:

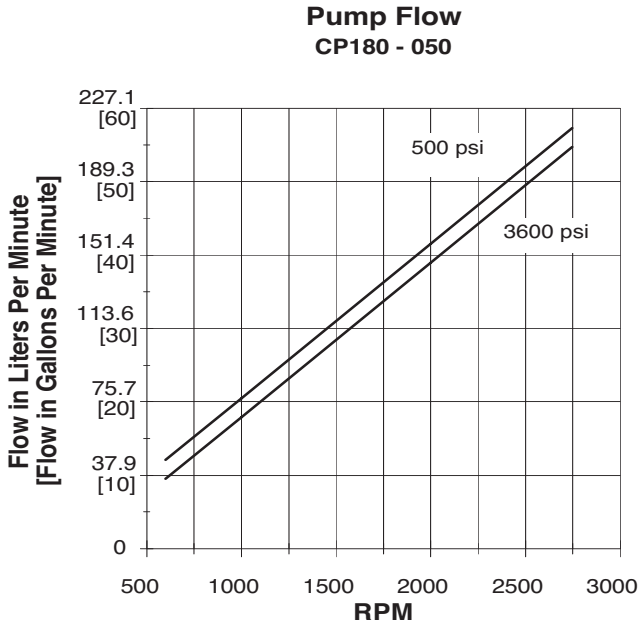

Figure 22:

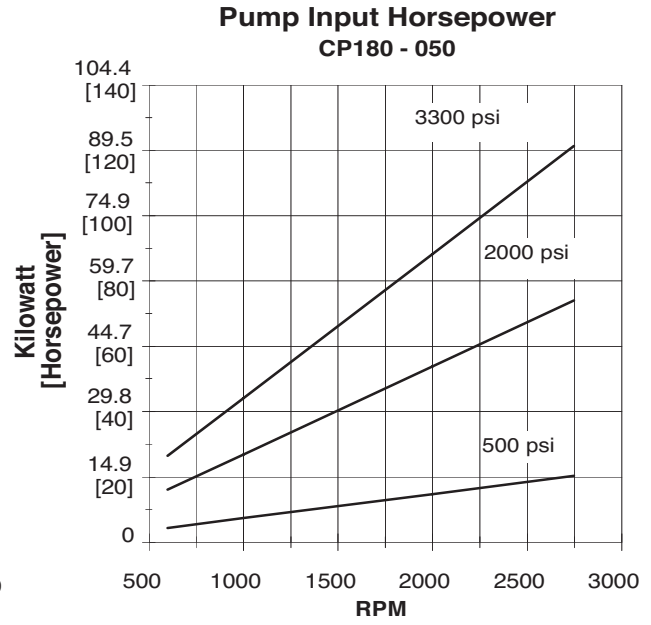

Figure 23:

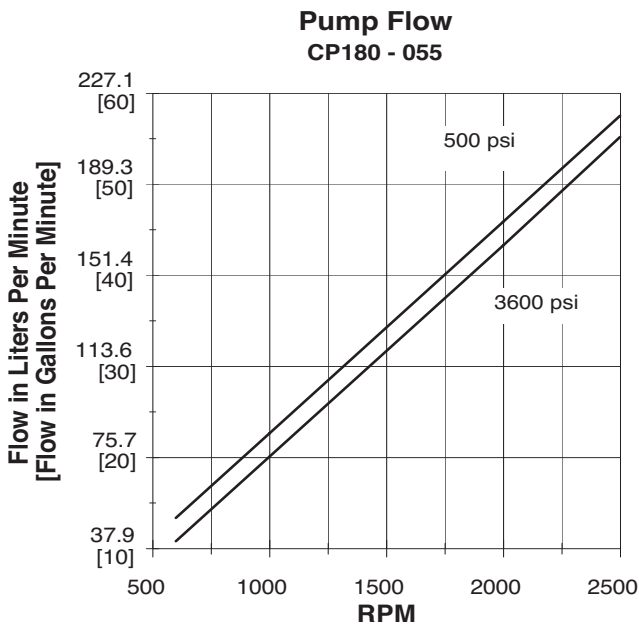
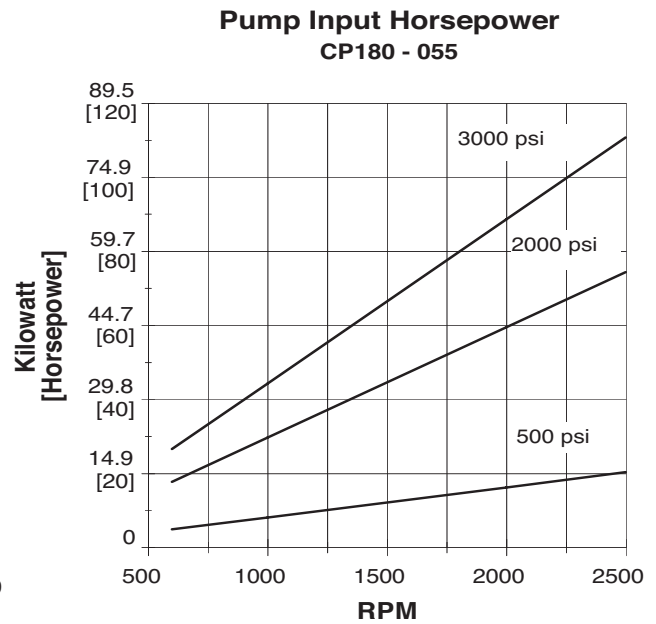

Figure 24:



CP 180 Performance Curves, (Continued)

[$v = 34 \text{ mm}^2/\text{s}$ (160 SUS), $\vartheta = 49^\circ \text{ C}$ (120°F)]

Figure 25:

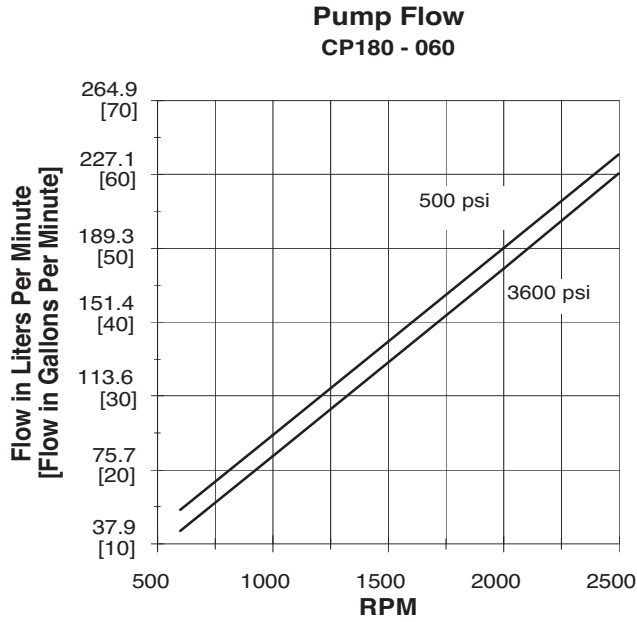
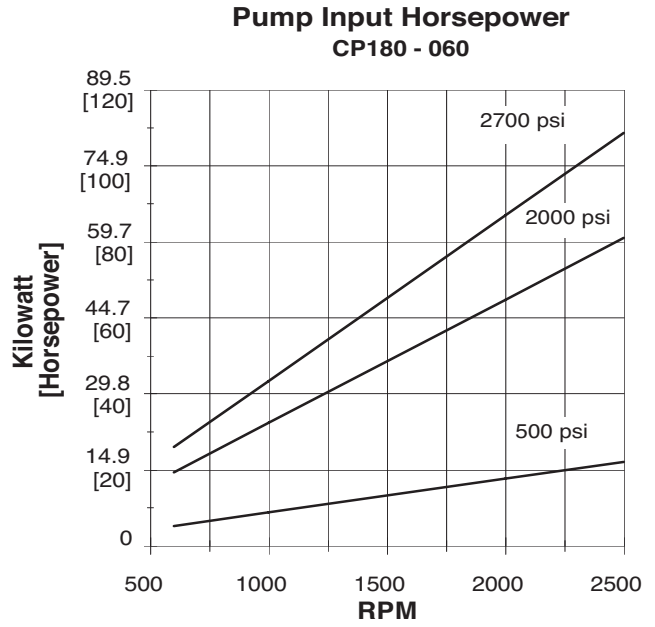

Figure 26:



CP 180 Single Gear Pump Dimensions

Figure 27:

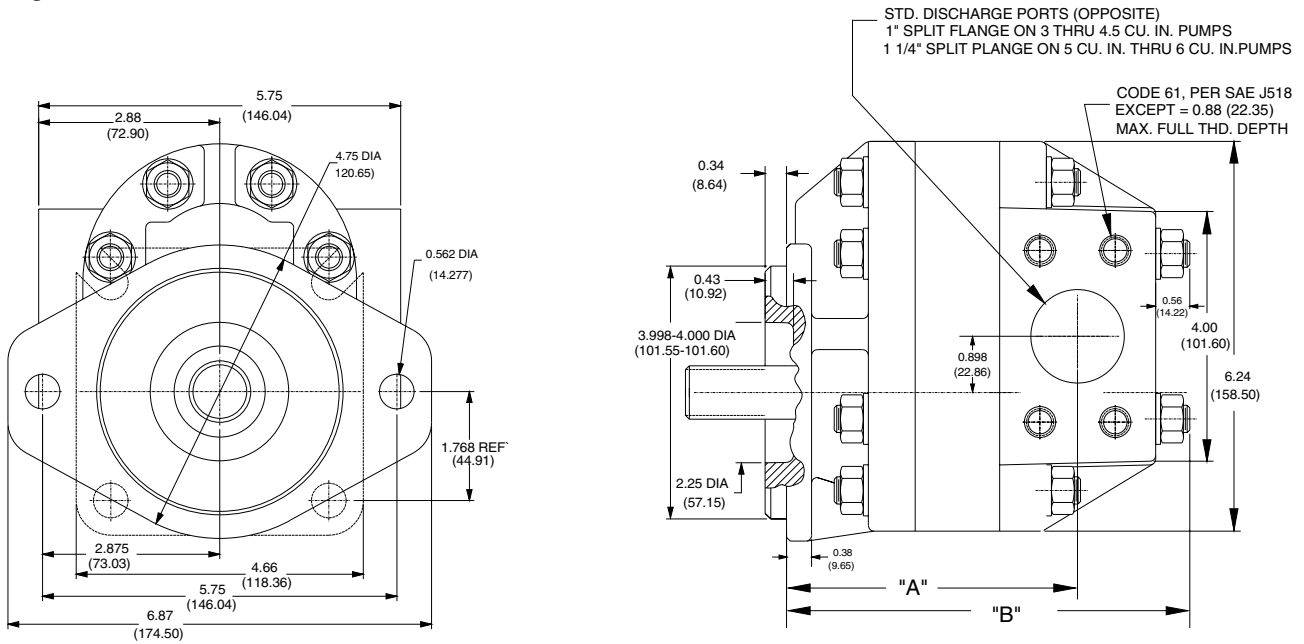

Table 3:

MOUNTING DIMENSIONS				
DISPLACEMENT CODE	"A"		"B"	
	IN	MM	IN	MM
020	4.46	113.31	5.71	145.06
023	4.55	115.57	5.80	147.32
026	4.67	118.62	5.92	150.37
030	4.81	122.17	6.06	153.92
032	4.87	123.70	6.12	155.45
035	4.98	126.49	6.23	158.24
040	5.16	131.06	6.41	162.81
045	5.33	135.38	6.58	167.13
050	5.51	139.95	6.76	171.70
055	5.69	144.53	6.94	176.28
060	5.86	148.84	7.11	180.59

CP 180 Single Gear Pump Cover and Shaft Options

Dimensions shown in inches xx.xx with metric dimensions (millimeters) shown in brackets (xx.xx).

Figure 28:

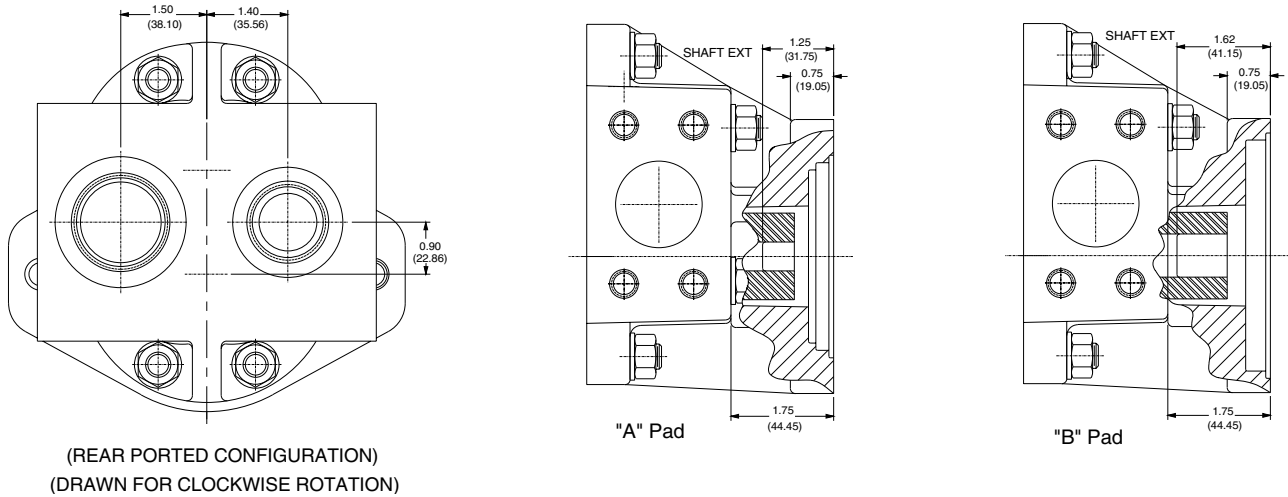
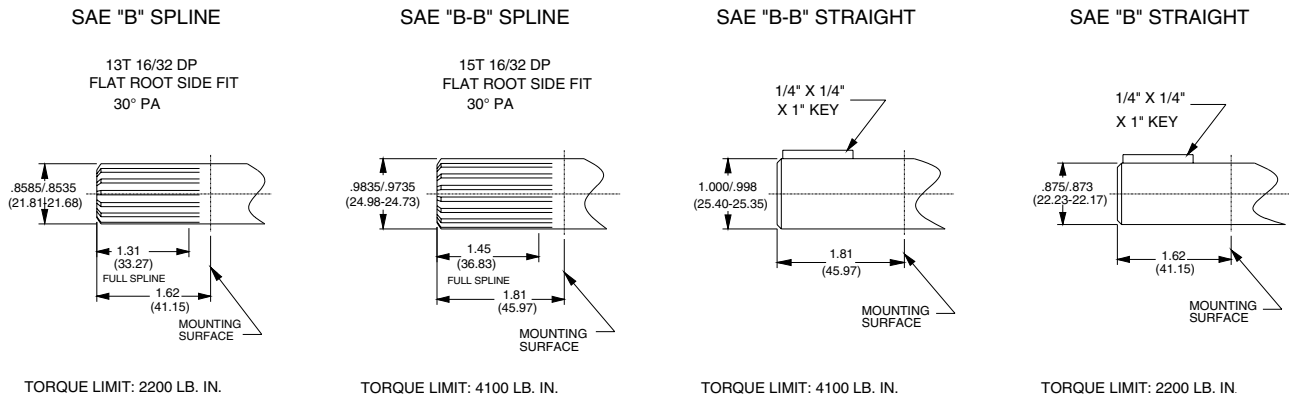

Figure 29:

MOUNTING SHAFTS AVAILABLE



CP 180 Priority Flow Divider Pump Dimensions and Options

Dimensions shown in inches xx.xx with metric dimensions (millimeters) shown in brackets (xx.xx).

Figure 30:

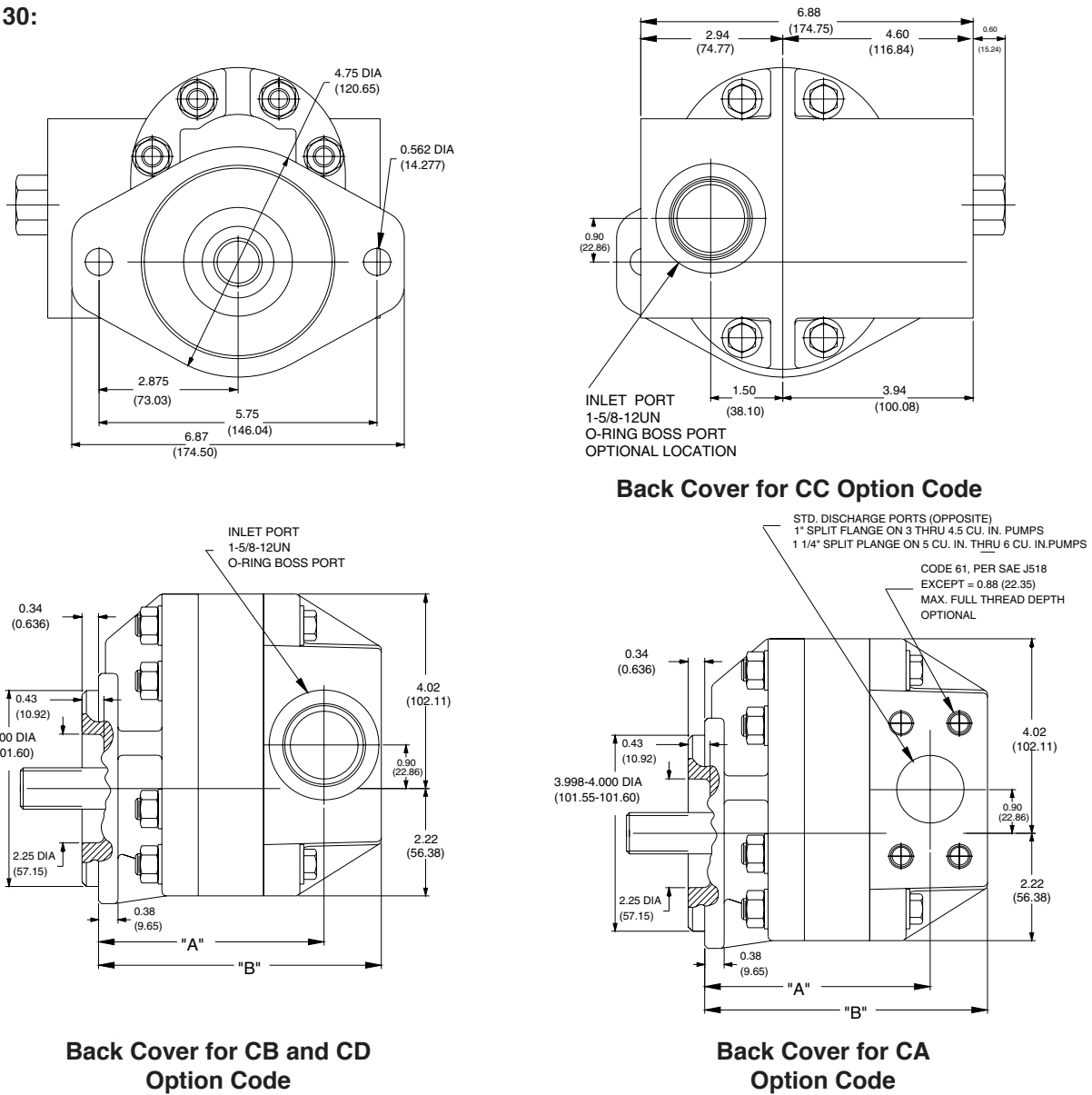
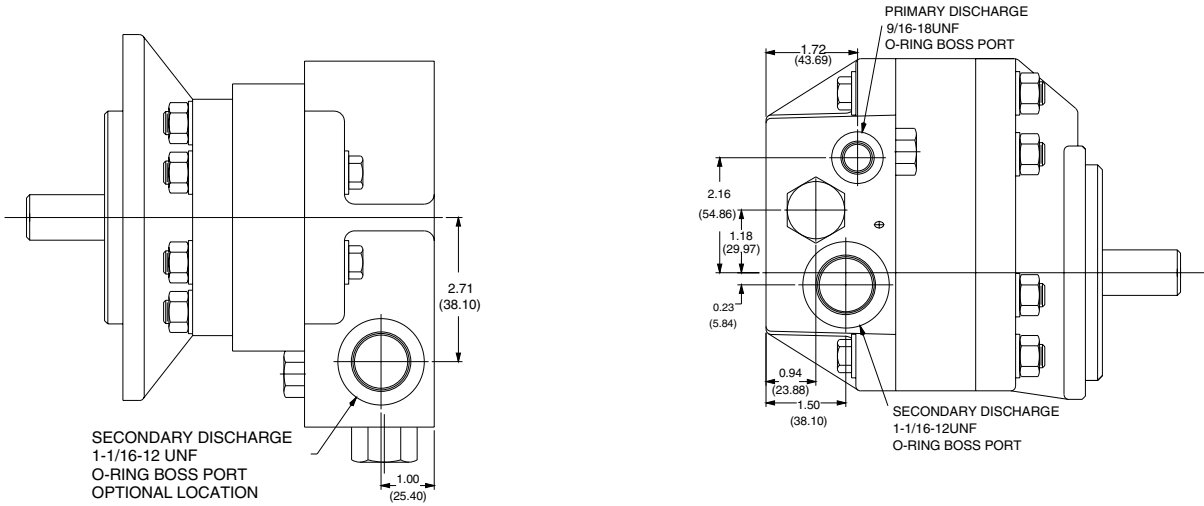

Table 4:

MOUNTING DIMENSIONS				
DISPLACEMENT CODE	"A"		"B"	
	IN	MM	IN	MM
020	4.46	113.31	5.71	145.06
023	4.55	115.57	5.80	147.32
026	4.67	118.62	5.92	150.37
030	4.81	122.17	6.06	153.92
032	4.87	123.70	6.12	155.45
035	4.98	126.49	6.23	158.24
040	5.16	131.06	6.41	162.81

CP 180 Priority Flow Divider Pump Dimensions and Options, Continued

Figure 31:



Back Cover Secondary Outlet for CD Option Code (Primary is on Side as shown for all other options).

Back Cover Outlets for CA, CB and CC Option Code

Figure 32:

Priority Relief Valve Dead Head Pressure
Dead Head Flow Vs Pressure

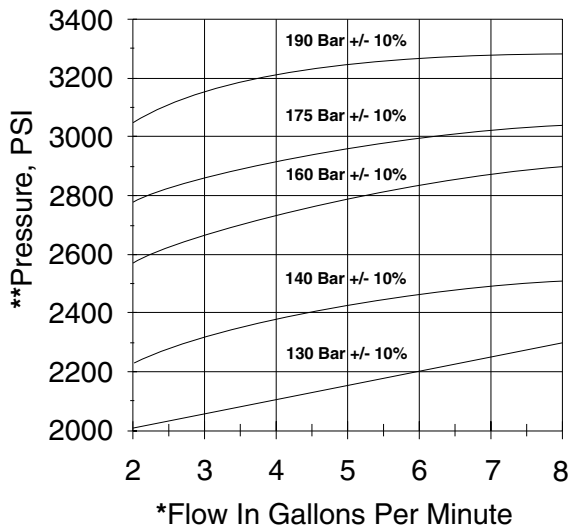

*Nominal flow setting at 30 gpm (115 L/min) maximum pump flow and auxiliary supply 1000 psi (69 Bar) greater than priority pressure.

**Nominal dead head pressure set at 1.0 gpm (3.85 L/min) flow

Figure 33:

Symbolic Schematic of PFD Option

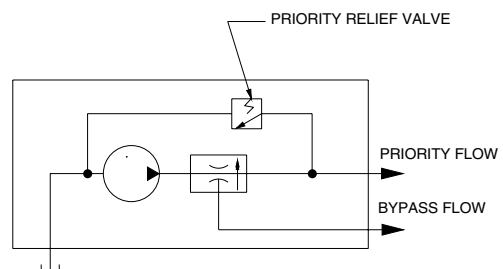

CPB (CP 180 Single, SAE "B" 2 Bolt Flange, Side Ports) Modular Ordering Code

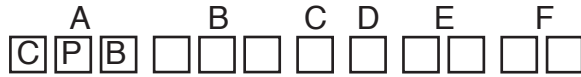

A: CPB 180 Series Pump (SAE "B" 2-Bolt Flange and Side Ports) _____ E: Front Drive Gear (Continued) _____

B: Model

- 020= 2.01 CIR (32.94 cc/rev)
- 023= 2.24 CIR (36.65 cc/rev)
- 026= 2.54 CIR (41.60 cc/rev)
- 030= 2.92 CIR (47.77 cc/rev)
- 032= 3.14 CIR (51.49 cc/rev)
- 035= 3.40 CIR (55.70 cc/rev)
- 040= 3.88 CIR (63.63 cc/rev)
- 045= 4.37 CIR (71.58 cc/rev)
- 050= 4.85 CIR (79.53 cc/rev)
- 055= 5.36 CIR (87.83 cc/rev)
- 060= 5.84 CIR (95.70 cc/rev)

C: Rotation

- R= Righthand (CW)
- L= Lefthand (CCW)

D: Seal Kit

- 2= Buna
- 4= Viton

E: Front Drive Gear (Choose One) _____

- | | |
|--------------------|--------------------|
| AU= 13T Spline 020 | BA= 15T Spline 020 |
| AR= 13T Spline 023 | AS= 15T Spline 023 |
| AV= 13T Spline 026 | BB= 15T Spline 026 |
| AA= 13T Spline 030 | AF= 15T Spline 030 |
| AX= 13T Spline 032 | BC= 15T Spline 032 |
| AB= 13T Spline 035 | AG= 15T Spline 035 |
| AC= 13T Spline 040 | AH= 15T Spline 040 |
| AD= 13T Spline 045 | AJ= 15T Spline 045 |
| AE= 13T Spline 050 | AK= 15T Spline 050 |
| AY= 13T Spline 055 | BD= 15T Spline 055 |
| AZ= 13T Spline 060 | BE= 15T Spline 060 |

- BF= 1" Straight Key Shaft 020
- AT= 1" Straight Key Shaft 023
- BG= 1" Straight Key Shaft 026
- AL= 1" Straight Key Shaft 030
- BH= 1" Straight Key Shaft 032
- AM= 1" Straight Key Shaft 035
- AN= 1" Straight Key Shaft 040
- AP= 1" Straight Key Shaft 045
- AQ= 1" Straight Key Shaft 050
- BI= 1" Straight Key Shaft 055
- BJ= 1" Straight Key Shaft 060

- BK= .88" Straight Key Shaft 020
- BL= .88" Straight Key Shaft 023
- BM= .88" Straight Key Shaft 026
- BN= .88" Straight Key Shaft 030
- BO= .88" Straight Key Shaft 032
- BP= .88" Straight Key Shaft 035
- BQ= .88" Straight Key Shaft 040
- BR= .88" Straight Key Shaft 045
- BS= .88" Straight Key Shaft 050
- BT= .88" Straight Key Shaft 055
- BU= .88" Straight Key Shaft 060

F: Rear Cover/Port Code _____

- "O" Ring Boss, 1.25" In, 1.00" Out
- AL= Plain Rear Cover
 - AM= LH (CCW) Aux. W/ SAE "A" 2 Bolt 9T
 - AN= RH (CW) Aux. W/ SAE "A" 2 Bolt 9T
 - BM= LH (CCW) Aux. W/ SAE "A" 2 Bolt 11T
 - BN= RH (CW) Aux. W/ SAE "A" 2 Bolt 11T
 - AP= LH (CCW) Aux. W/ SAE "B" 2 Bolt 13T
 - AQ= RH (CW) Aux. W/ SAE "B" 2 Bolt 13T
 - BP= LH (CCW) Aux. W/ SAE "B" 2 Bolt 15T
 - BQ= RH (CW) Aux. W/ SAE "B" 2 Bolt 15T

SAE Code 61 Split Flange, 1.25" In, 1.00" Out

- AR= Plain Rear Cover
- AS= LH (CCW) Aux. W/ SAE "A" 2 Bolt 9T
- AT= RH (CW) Aux. W/ SAE "A" 2 Bolt 9T
- BR= LH (CCW) Aux. W/ SAE "A" 2 Bolt 11T
- BS= RH (CW) Aux. W/ SAE "A" 2 Bolt 11T
- AU= LH (CCW) Aux. W/ SAE "B" 2 Bolt 13T
- AV= RH (CW) Aux. W/ SAE "B" 2 Bolt 13T
- BT= LH (CCW) Aux. W/ SAE "B" 2 Bolt 15T
- BU= RH (CW) Aux. W/ SAE "B" 2 Bolt 15T

SAE Code 61 Split Flange, 1.50" In, 1.25" Out

- AW= Plain Rear Cover
- AX= LH (CCW) Aux. W/ SAE "A" 2 Bolt 9T
- AY= RH (CW) Aux. W/ SAE "A" 2 Bolt 9T
- BV= LH (CCW) Aux. W/ SAE "A" 2 Bolt 11T
- BW= RH (CW) Aux. W/ SAE "A" 2 Bolt 11T
- AZ= LH (CCW) Aux. W/ SAE "B" 2 Bolt 13T
- BA= RH (CW) Aux. W/ SAE "B" 2 Bolt 13T
- BX= LH (CCW) Aux. W/ SAE "B" 2 Bolt 15T
- BY= RH (CW) Aux. W/ SAE "B" 2 Bolt 15T

Optional Aux Pad Ship Cover Kit

- SAE "A" pad = 20086-17
- SAE "B" pad = 20086-18

CPC (CP 180 Single, SAE "B" 2 Bolt Flange, Rear Ports) Modular Ordering Code

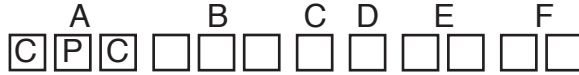

A: CPC 180 Series Pump (SAE "B" 2-Bolt Flange and Rear Ports) E: Front Drive Gear (Continued)

B: Model

- 020= 2.01 CIR (32.94 cc/rev)
- 023= 2.24 CIR (36.65 cc/rev)
- 026= 2.54 CIR (41.60 cc/rev)
- 030= 2.92 CIR (47.77 cc/rev)
- 032= 3.14 CIR (51.49 cc/rev)
- 035= 3.40 CIR (55.70 cc/rev)
- 040= 3.88 CIR (63.63 cc/rev)
- 045= 4.37 CIR (71.58 cc/rev)
- 050= 4.85 CIR (79.53 cc/rev)
- 055= 5.36 CIR (87.83 cc/rev)
- 060= 5.84 CIR (95.70 cc/rev)

- BK= .88" Straight Key Shaft 020
- BL= .88" Straight Key Shaft 023
- BM= .88" Straight Key Shaft 026
- BN= .88" Straight Key Shaft 030
- BO= .88" Straight Key Shaft 032
- BP= .88" Straight Key Shaft 035
- BQ= .88" Straight Key Shaft 040
- BR= .88" Straight Key Shaft 045
- BS= .88" Straight Key Shaft 050
- BT= .88" Straight Key Shaft 055
- BU= .88" Straight Key Shaft 060

C: Rotation

- R= Righthand (CW)
- L= Lefthand (CCW)

F: Rear Cover/Port Code

- BB= "O" Ring Boss, 1.00" In, 0.75" Out Plain Rear Cover
- BC= "O" Ring Boss, 1.25" In, 1.00" Out Plain Rear Cover

D: Seal Kit

- 2= Buna
- 4= Viton

E: Front Drive Gear (Choose One)

- | | |
|--------------------|--------------------|
| AU= 13T Spline 020 | BA= 15T Spline 020 |
| AR= 13T Spline 023 | AS= 15T Spline 023 |
| AV= 13T Spline 026 | BB= 15T Spline 026 |
| AA= 13T Spline 030 | AF= 15T Spline 030 |
| AX= 13T Spline 032 | BC= 15T Spline 032 |
| AB= 13T Spline 035 | AG= 15T Spline 035 |
| AC= 13T Spline 040 | AH= 15T Spline 040 |
| AD= 13T Spline 045 | AJ= 15T Spline 045 |
| AE= 13T Spline 050 | AK= 15T Spline 050 |
| AY= 13T Spline 055 | BD= 15T Spline 055 |
| AZ= 13T Spline 060 | BE= 15T Spline 060 |

- BF= 1" Straight Key Shaft 020
- AT= 1" Straight Key Shaft 023
- BG= 1" Straight Key Shaft 026
- AL= 1" Straight Key Shaft 030
- BH= 1" Straight Key Shaft 032
- AM= 1" Straight Key Shaft 035
- AN= 1" Straight Key Shaft 040
- AP= 1" Straight Key Shaft 045
- AQ= 1" Straight Key Shaft 050
- BI= 1" Straight Key Shaft 055
- BJ= 1" Straight Key Shaft 060

CPD (CP 180 Single, SAE "B" 4 Bolt Flange, Side Ports) Modular Ordering Code

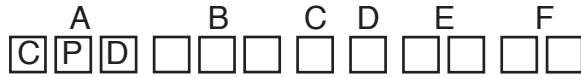

A: CPB 180 Series Pump (SAE "B" 2-Bolt Flange and Side Ports) _____ E: Front Drive Gear (Continued) _____

B: Model

- 020= 2.01 CIR (32.94 cc/rev)
- 023= 2.24 CIR (36.65 cc/rev)
- 026= 2.54 CIR (41.60 cc/rev)
- 030= 2.92 CIR (47.77 cc/rev)
- 032= 3.14 CIR (51.49 cc/rev)
- 035= 3.40 CIR (55.70 cc/rev)
- 040= 3.88 CIR (63.63 cc/rev)
- 045= 4.37 CIR (71.58 cc/rev)
- 050= 4.85 CIR (79.53 cc/rev)
- 055= 5.36 CIR (87.83 cc/rev)
- 060= 5.84 CIR (95.70 cc/rev)

C: Rotation

- R= Righthand (CW)
- L= Lefthand (CCW)

D: Seal Kit

- 2= Buna
- 4= Viton

E: Front Drive Gear (Choose One) _____

- | | |
|--------------------|--------------------|
| AU= 13T Spline 020 | BA= 15T Spline 020 |
| AR= 13T Spline 023 | AS= 15T Spline 023 |
| AV= 13T Spline 026 | BB= 15T Spline 026 |
| AA= 13T Spline 030 | AF= 15T Spline 030 |
| AX= 13T Spline 032 | BC= 15T Spline 032 |
| AB= 13T Spline 035 | AG= 15T Spline 035 |
| AC= 13T Spline 040 | AH= 15T Spline 040 |
| AD= 13T Spline 045 | AJ= 15T Spline 045 |
| AE= 13T Spline 050 | AK= 15T Spline 050 |
| AY= 13T Spline 055 | BD= 15T Spline 055 |
| AZ= 13T Spline 060 | BE= 15T Spline 060 |

- BF= 1" Straight Key Shaft 020
- AT= 1" Straight Key Shaft 023
- BG= 1" Straight Key Shaft 026
- AL= 1" Straight Key Shaft 030
- BH= 1" Straight Key Shaft 032
- AM= 1" Straight Key Shaft 035
- AN= 1" Straight Key Shaft 040
- AP= 1" Straight Key Shaft 045
- AQ= 1" Straight Key Shaft 050
- BI= 1" Straight Key Shaft 055
- BJ= 1" Straight Key Shaft 060

- BK= .88" Straight Key Shaft 020
- BL= .88" Straight Key Shaft 023
- BM= .88" Straight Key Shaft 026
- BN= .88" Straight Key Shaft 030
- BO= .88" Straight Key Shaft 032
- BP= .88" Straight Key Shaft 035
- BQ= .88" Straight Key Shaft 040
- BR= .88" Straight Key Shaft 045
- BS= .88" Straight Key Shaft 050
- BT= .88" Straight Key Shaft 055
- BU= .88" Straight Key Shaft 060

F: Rear Cover/Port Code _____

- "O" Ring Boss, 1.25" In, 1.00" Out
- AL= Plain Rear Cover
 - AM= LH (CCW) Aux. W/ SAE "A" 2 Bolt 9T
 - AN= RH (CW) Aux. W/ SAE "A" 2 Bolt 9T
 - BM= LH (CCW) Aux. W/ SAE "A" 2 Bolt 11T
 - BN= RH (CW) Aux. W/ SAE "A" 2 Bolt 11T
 - AP= LH (CCW) Aux. W/ SAE "B" 2 Bolt 13T
 - AQ= RH (CW) Aux. W/ SAE "B" 2 Bolt 13T
 - BP= LH (CCW) Aux. W/ SAE "B" 2 Bolt 15T
 - BQ= RH (CW) Aux. W/ SAE "B" 2 Bolt 15T

- SAE Code 61 Split Flange, 1.25" In, 1.00" Out
- AR= Plain Rear Cover
 - AS= LH (CCW) Aux. W/ SAE "A" 2 Bolt 9T
 - AT= RH (CW) Aux. W/ SAE "A" 2 Bolt 9T
 - BR= LH (CCW) Aux. W/ SAE "A" 2 Bolt 11T
 - BS= RH (CW) Aux. W/ SAE "A" 2 Bolt 11T
 - AU= LH (CCW) Aux. W/ SAE "B" 2 Bolt 13T
 - AV= RH (CW) Aux. W/ SAE "B" 2 Bolt 13T
 - BT= LH (CCW) Aux. W/ SAE "B" 2 Bolt 15T
 - BU= RH (CW) Aux. W/ SAE "B" 2 Bolt 15T

- SAE Code 61 Split Flange, 1.50" In, 1.25" Out
- AW= Plain Rear Cover
 - AX= LH (CCW) Aux. W/ SAE "A" 2 Bolt 9T
 - AY= RH (CW) Aux. W/ SAE "A" 2 Bolt 9T
 - BV= LH (CCW) Aux. W/ SAE "A" 2 Bolt 11T
 - BW= RH (CW) Aux. W/ SAE "A" 2 Bolt 11T
 - AZ= LH (CCW) Aux. W/ SAE "B" 2 Bolt 13T
 - BA= RH (CW) Aux. W/ SAE "B" 2 Bolt 13T
 - BX= LH (CCW) Aux. W/ SAE "B" 2 Bolt 15T
 - BY= RH (CW) Aux. W/ SAE "B" 2 Bolt 15T

- Optional Aux Pad Ship Cover Kit
- SAE "A" pad = 20086-17
 - SAE "B" pad = 20086-18

CPJ (CP 180 Single, SAE "B" 2 Bolt Flange and PFD Cover) Modular Ordering Code



A: CPJ 180 Series Pump
 (SAE "B" 2-Bolt Flange and Priority Flow Divider Cover)

B: Model

- 020= 2.01 CIR (32.94 cc/rev)
- 023= 2.24 CIR (36.65 cc/rev)
- 026= 2.54 CIR (41.60 cc/rev)
- 030= 2.92 CIR (47.77 cc/rev)
- 032= 3.14 CIR (51.49 cc/rev)
- 035= 3.40 CIR (55.70 cc/rev)
- 040= 3.88 CIR (63.63 cc/rev)

C: Rotation

- R= Righthand (CW)
- L= Lefthand (CCW)

D: Seal Kit

- 2= Buna
- 4= Viton

E: Front Drive Gear (Choose One)

- AU= 13T Spline 020
- AR= 13T Spline 023
- AV= 13T Spline 026
- AA= 13T Spline 030
- AX= 13T Spline 032
- AB= 13T Spline 035
- AC= 13T Spline 040

- BA= 15T Spline 020
- AS= 15T Spline 023
- BB= 15T Spline 026
- AF= 15T Spline 030
- BC= 15T Spline 032
- AG= 15T Spline 035
- AH= 15T Spline 040

- BF= 1" Straight Key Shaft 020
- AT= 1" Straight Key Shaft 023
- BG= 1" Straight Key Shaft 026
- AL= 1" Straight Key Shaft 030
- BH= 1" Straight Key Shaft 032
- AM= 1" Straight Key Shaft 035
- AN= 1" Straight Key Shaft 040

- BK= .88" Straight Key Shaft 020
- BL= .88" Straight Key Shaft 023
- BM= .88" Straight Key Shaft 026
- BN= .88" Straight Key Shaft 030
- BO= .88" Straight Key Shaft 032
- BP= .88" Straight Key Shaft 035
- BQ= .88" Straight Key Shaft 040

F: Rear Cover/Port Code

- CA= Priority Flow Divider Rear Cover
1.25" Side Split Flange Inlet and Side "O" Ring
Boss Outlets, .375" Priority & .75" Auxiliary
- CB= Priority Flow Divider Rear Cover
Side "O" Ring Boss Ports, 1.25" Inlet, .375"
Priority, & .75" Auxiliary
- CC= Priority Flow Divider Rear Cover
1.25" Rear "O" Ring Boss Inlet and Side "O" Ring
Boss Outlets, .375" Priority, & .75" Auxiliary
- CD= Priority Flow Divider Rear Cover
1.25" Side "O" Ring Boss Inlet and .375" Side
Priority Outlet, and .75" Top Auxiliary Outlet

G: Priority Flow Setting Code (+/- 10%)*

- 020= 2 GPM (7.7 L/Min)
- 040= 4 GPM (15.4 L/Min)
- 050= 5 GPM (19.2 L/Min)
- 060= 6 GPM (23.1 L/Min)
- 072= 7.2 GPM (27.7 L/Min)
- 080= 8 GPM (30.7 L/Min)

*Nominal flow setting at 30 gpm (115 L/min) maximum pump flow and auxiliary supply 1000 psi (69 Bar) greater than priority pressure.

H: Priority Pressure Setting Code (+/- 10%)**

- 130= 130 Bar (1885 psi)
- 140= 140 Bar (2030 psi)
- 160= 160 Bar (2320 psi)
- 175= 175 Bar (2537 psi)
- 190= 190 Bar (2755 psi)

**Nominal dead head pressure set at 1.0 gpm (3.85 L/min) flow. Refer to "Flow vs Pressure Curve" below.

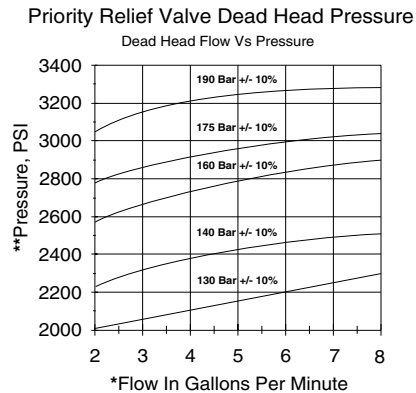

CP 180 Tandem Gear Pumps

- 11 Sizes from 2.01 to 5.84 cu.in/rev. (32.94 to 95.70 cc/rev.)
- SAE 2-Bolt "B" Mounting Flange
- SAE 4-Bolt "B" Mounting Flange
- Spline or Keyed Shaft
- SAE 4-Bolt Split Flange Side Ported, Code 61
- "Nitrile" Seals - Standard, "Viton" Seals - Optional
- Single Inlet**
- SAE 'O' Ring Boss Ports - Side and Rear
- Clockwise or Counterclockwise Rotation
- Pressure - 3600 PSI Continuous (4500 PSI Peak) Speeds to 3000 RPM
- Auxiliary Pad Rear Cover - SAE 2 Bolt "A" & "B" Pad Mounts

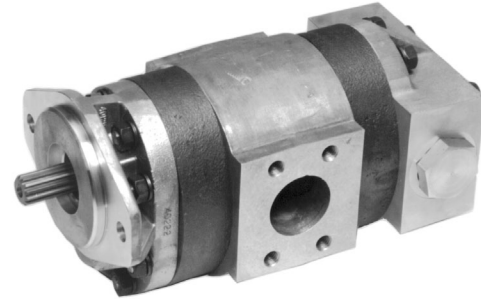

* For combinations other than those shown, contact QCC.

** For tandems requiring separate inlets, use CP180 single pump (rear) mounted to an optional SAE "B" pad on a front section CP180 single pump.

★ AVAILABLE COMBINATIONS

Figure 34:

		REAR						
		020	023	026	030	032	035	040
FRONT	020	★	★	★	★	★	★	★
	023	★	★	★	★	★	★	★
	026	★	★	★	★	★	★	★
	030	★	★	★	★	★	★	★
	032	★	★	★	★	★	★	★
	035	★	★	★	★	★	★	★
	040	★	★	★	★	★	★	★
	045	★	★	★	★	★	★	★
	050	★	★	★	★	★	★	★
	055	★	★	★	★	★	★	★
	060	★	★	★	★	★	★	★

CP 180 Tandem Gear Pump Dimensions

Dimensions shown in inches xx.xx with metric dimensions (millimeters) shown in brackets (xx.xx).

Figure 35:

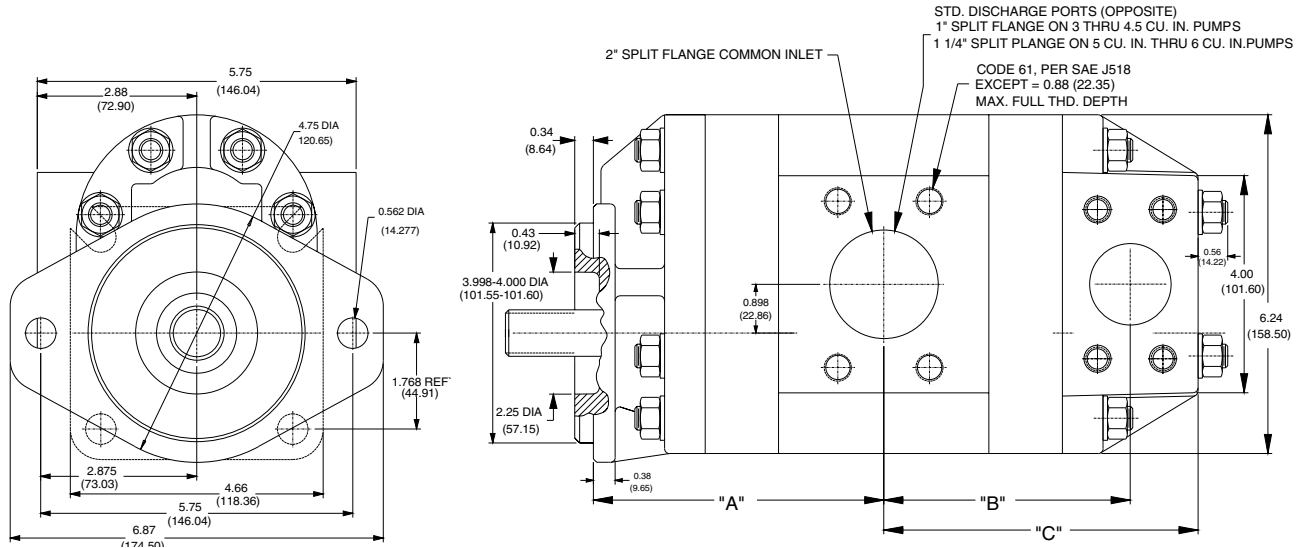

NOTE: Please refer to page 19 for pump cover and shaft options.

Table 5:

MOUNTING DIMENSIONS						
DISPLACEMENT CODE	"A"		"B"		"C"	
	IN	MM	IN	MM	IN	MM
020-020	5.15	130.81	4.34	110.24	5.59	142.99
023-023	5.24	133.10	4.43	115.06	5.68	144.22
026-026	5.36	136.14	4.55	115.57	5.80	147.32
030-030	5.50	139.70	4.69	119.22	5.94	150.42
032-032	5.55	140.97	4.74	120.40	5.99	152.15
035-035	5.68	144.27	4.87	123.77	6.12	155.88
040-040	5.85	148.59	5.04	128.02	6.29	160.01
045-040	6.03	153.16	5.04	128.02	6.29	159.77
050-040	6.20	157.48	5.04	128.02	6.29	159.77
055-040	6.38	162.05	5.04	128.02	6.29	159.77
060-040	6.55	166.37	5.04	128.02	6.29	159.77

CPE (CP 180 Tandem, SAE "B" 2-Bolt Flange, Side Ports) Modular Ordering Code



A: CPE 180 Series Tandem Pump
(SAE "B" 2-Bolt Flange and Side Ports)

F: Front Drive Gear (Continued)

B: Front Section Model

- 020= 2.01 CIR (32.94 cc/rev)
- 023= 2.24 CIR (36.65 cc/rev)
- 026= 2.54 CIR (41.60 cc/rev)
- 030= 2.92 CIR (47.77 cc/rev)
- 032= 3.14 CIR (51.49 cc/rev)
- 035= 3.40 CIR (55.70 cc/rev)
- 040= 3.88 CIR (63.63 cc/rev)
- 045= 4.37 CIR (71.58 cc/rev)
- 050= 4.85 CIR (79.53 cc/rev)
- 055= 5.36 CIR (87.83 cc/rev)
- 060= 5.84 CIR (95.70 cc/rev)

- BA= 15T Spline 020
- AS= 15T Spline 023
- BB= 15T Spline 026
- AF= 15T Spline 030
- BC= 15T Spline 032
- AG= 15T Spline 035
- AH= 15T Spline 040
- AJ= 15T Spline 045
- AK= 15T Spline 050
- BD= 15T Spline 055
- BE= 15T Spline 060

C: Rear Section Model

- 020= 2.01 CIR (32.94 cc/rev)
- 023= 2.24 CIR (36.65 cc/rev)
- 026= 2.54 CIR (41.60 cc/rev)
- 030= 2.92 CIR (47.77 cc/rev)
- 032= 3.14 CIR (51.49 cc/rev)
- 035= 3.40 CIR (55.70 cc/rev)
- 040= 3.88 CIR (63.63 cc/rev)

- BF= 1" Straight Key Shaft 020
- AT= 1" Straight Key Shaft 023
- BG= 1" Straight Key Shaft 026
- AL= 1" Straight Key Shaft 030
- BH= 1" Straight Key Shaft 032
- AM= 1" Straight Key Shaft 035
- AN= 1" Straight Key Shaft 040
- AP= 1" Straight Key Shaft 045
- AQ= 1" Straight Key Shaft 050
- BL= 1" Straight Key Shaft 055
- BJ= 1" Straight Key Shaft 060

D: Rotation

- R= Righthand (CW)
- L= Lefthand (CCW)

- BK= .88" Straight Key Shaft 020
- BL= .88" Straight Key Shaft 023
- BM= .88" Straight Key Shaft 026
- BN= .88" Straight Key Shaft 030
- BO= .88" Straight Key Shaft 032
- BP= .88" Straight Key Shaft 035
- BQ= .88" Straight Key Shaft 040
- BR= .88" Straight Key Shaft 045
- BS= .88" Straight Key Shaft 050
- BT= .88" Straight Key Shaft 055
- BU= .88" Straight Key Shaft 060

E: Seal Kit

- 2= Buna
- 4= Viton

F: Front Drive Gear (Choose One)

- AU= 13T Spline 020
- AR= 13T Spline 023
- AV= 13T Spline 026
- AA= 13T Spline 030
- AX= 13T Spline 032
- AB= 13T Spline 035
- AC= 13T Spline 040
- AD= 13T Spline 045
- AE= 13T Spline 050
- AY= 13T Spline 055
- AZ= 13T Spline 060

G: Rear Drive Gear

- B= 020 W/ Auxiliary Drive
- C= 023 W/ Auxiliary Drive
- D= 026 W/ Auxiliary Drive
- 1= 030 W/ Auxiliary Drive
- E= 032 W/ Auxiliary Drive
- 2= 035 W/ Auxiliary Drive
- 3= 040 W/ Auxiliary Drive

CPE (CP 180 Tandem, SAE "B" 2-Bolt Flange, Side Ports) Modular Ordering Code, cont.

H: Rear Cover/Port Code

SAE Code 61 Split Flange, No Inlet, 1.00" Out
 AA= Plain Rear Cover
 AB= LH (CCW) Aux. W/ SAE "A" 2 Bolt 9T
 AC= RH (CW) Aux. W/ SAE "A" 2 Bolt 9T
 BD= LH (CCW) Aux. W/ SAE "A" 2 Bolt 11T
 BE= RH (CW) Aux. W/ SAE "A" 2 Bolt 11T
 AD= LH (CCW) Aux. W/ SAE "B" 2 Bolt 13T
 AE= RH (CW) Aux. W/ SAE "B" 2 Bolt 13T

SAE Code 61 Split Flange, No Inlet, 1.25" Out
 AF= Plain Rear Cover
 AG= LH (CCW) Aux. W/ SAE "A" 2 Bolt 9T
 AH= RH (CW) Aux. W/ SAE "A" 2 Bolt 9T
 BH= LH (CCW) Aux. W/ SAE "A" 2 Bolt 11T
 BJ= RH (CW) Aux. W/ SAE "A" 2 Bolt 11T
 AJ= LH (CCW) Aux. W/ SAE "B" 2 Bolt 13T
 AK= RH (CW) Aux. W/ SAE "B" 2 Bolt 13T

I: Center Section Rotation/Port Code

SAE Code 61 Split Flange Ports
 1= LH (CCW), 2.00" Common Inlet, 1.00" Outlet
 2= RH (CW), 2.00" Common Inlet, 1.00" Outlet
 3= LH (CCW), 2.00" Common Inlet, 1.25" Outlet
 4= RH (CW), 2.00" Common Inlet, 1.25" Outlet

J: Assembly Stud Kit

Combined Displacement*	Combined Displacement*
BX= 040	AT= 070
BY= 043	AT= 071
BZ= 046	DH= 072
CD= 049	DH= 073
CA= 050	AU= 075
CB= 052	DJ= 076
CB= 053	DJ= 077
CC= 055	DJ= 078
CC= 056	AV= 080
CE= 058	AV= 081
AA= 060	DL= 082
AA= 061	DL= 083
CG= 062	AZ= 085
CG= 063	DM= 086
CG= 064	DM= 087
AB= 065	BC= 090
CF= 066	DN= 092
CH= 067	BE= 095
CH= 068	BF= 100

*NOTE: "Combined Displacement" = Equals Sum of Front and Rear Model Codes
 Examples: 020+020=040, 050+023=073, and 040+035=075

CPF (CP 180 Tandem, SAE "B" 2 Bolt Flange, Rear Ports) Modular Ordering Code



A: CPF 180 Series Tandem Pump
 (SAE "B" 2-Bolt Flange and Rear Ports)

- B: Front Section Model
- 020= 2.01 CIR (32.94 cc/rev)
 - 023= 2.24 CIR (36.65 cc/rev)
 - 026= 2.54 CIR (41.60 cc/rev)
 - 030= 2.92 CIR (47.77 cc/rev)
 - 032= 3.14 CIR (51.49 cc/rev)
 - 035= 3.40 CIR (55.70 cc/rev)
 - 040= 3.88 CIR (63.63 cc/rev)
 - 045= 4.37 CIR (71.58 cc/rev)
 - 050= 4.85 CIR (79.53 cc/rev)
 - 055= 5.36 CIR (87.83 cc/rev)
 - 060= 5.84 CIR (95.70 cc/rev)

- C: Rear Section Model
- 020= 2.01 CIR (32.94 cc/rev)
 - 023= 2.24 CIR (36.65 cc/rev)
 - 026= 2.54 CIR (41.60 cc/rev)
 - 030= 2.92 CIR (47.77 cc/rev)
 - 032= 3.14 CIR (51.49 cc/rev)
 - 035= 3.40 CIR (55.70 cc/rev)
 - 040= 3.88 CIR (63.63 cc/rev)

- D: Rotation
- R= Righthand (CW)
 - L= Lefthand (CCW)

- E: Seal Kit
- 2= Buna
 - 4= Viton

- F: Front Drive Gear (Choose One)
- AU= 13T Spline 020
 - AR= 13T Spline 023
 - AV= 13T Spline 026
 - AA= 13T Spline 030
 - AX= 13T Spline 032
 - AB= 13T Spline 035
 - AC= 13T Spline 040
 - AD= 13T Spline 045
 - AE= 13T Spline 050
 - AY= 13T Spline 055
 - AZ= 13T Spline 060

F: Front Drive Gear (Continued)

- BA= 15T Spline 020
- AS= 15T Spline 023
- BB= 15T Spline 026
- AF= 15T Spline 030
- BC= 15T Spline 032
- AG= 15T Spline 035
- AH= 15T Spline 040
- AJ= 15T Spline 045
- AK= 15T Spline 050
- BD= 15T Spline 055
- BE= 15T Spline 060

- BF= 1" Straight Key Shaft 020
- AT= 1" Straight Key Shaft 023
- BG= 1" Straight Key Shaft 026
- AL= 1" Straight Key Shaft 030
- BH= 1" Straight Key Shaft 032
- AM= 1" Straight Key Shaft 035
- AN= 1" Straight Key Shaft 040
- AP= 1" Straight Key Shaft 045
- AQ= 1" Straight Key Shaft 050
- BI= 1" Straight Key Shaft 055
- BJ= 1" Straight Key Shaft 060

- BK= .88" Straight Key Shaft 020
- BL= .88" Straight Key Shaft 023
- BM= .88" Straight Key Shaft 026
- BN= .88" Straight Key Shaft 030
- BO= .88" Straight Key Shaft 032
- BP= .88" Straight Key Shaft 035
- BQ= .88" Straight Key Shaft 040
- BR= .88" Straight Key Shaft 045
- BS= .88" Straight Key Shaft 050
- BT= .88" Straight Key Shaft 055
- BU= .88" Straight Key Shaft 060

G: Rear Drive Gear

- B= 020 W/ Auxiliary Drive
- C= 023 W/ Auxiliary Drive
- D= 026 W/ Auxiliary Drive
- 1= 030 W/ Auxiliary Drive
- E= 032 W/ Auxiliary Drive
- 2= 035 W/ Auxiliary Drive
- 3= 040 W/ Auxiliary Drive

CPF (CP 180 Tandem, SAE "B" 2 Bolt Flange, Rear Ports) Modular Ordering Code, cont.

H: Rear Cover/Port Code

BB= Rear "O" Ring Boss, 1.00" In, 0.75" Out
Plain Rear Cover

BC= Rear "O" Ring Boss, 1.25" In, 1.00" Out
Plain Rear Cover

I: Center Section Rotation/Port Code

SAE Code 61 Split Flange Ports

- 1= LH (CCW), 2.00" Common Inlet, 1.00" Outlet
- 2= RH (CW), 2.00" Common Inlet, 1.00" Outlet
- 3= LH (CCW), 2.00" Common Inlet, 1.25" Outlet
- 4= RH (CW), 2.00" Common Inlet, 1.25" Outlet

J: Assembly Stud Kit

<u>Combined Displacement*</u>	<u>Combined Displacement*</u>
CV= 040	AT= 070
CX= 043	AT= 071
CY= 046	DH= 072
DD= 049	DH= 073
CZ= 050	AU= 075
DA= 052	DJ= 076
DA= 053	DJ= 077
DB= 055	DJ= 078
DB= 056	AV= 080
DE= 058	AV= 081
AR= 060	DL= 082
AR= 061	DL= 083
DF= 062	AZ= 085
DF= 063	DM= 086
DF= 064	DM= 087
AS= 065	BC= 090
DK= 066	DN= 092
DK= 067	BE= 095
DG= 068	BF= 100

*NOTE: "Combined Displacement" = Equals Sum of Front and Rear Model Codes
Examples: 020+020=040, 050+023=073, and 040+035=075

CPG (CP 180 Tandem, SAE "B" 4 Bolt Flange, Side Ports), Modular Ordering Code



A: CPG 180 Series Tandem Pump
(SAE "B" 4-Bolt Flange and Side Ports)

B: Front Section Model

- 020= 2.01 CIR (32.94 cc/rev)
- 023= 2.24 CIR (36.65 cc/rev)
- 026= 2.54 CIR (41.60 cc/rev)
- 030= 2.92 CIR (47.77 cc/rev)
- 032= 3.14 CIR (51.49 cc/rev)
- 035= 3.40 CIR (55.70 cc/rev)
- 040= 3.88 CIR (63.63 cc/rev)
- 045= 4.37 CIR (71.58 cc/rev)
- 050= 4.85 CIR (79.53 cc/rev)
- 055= 5.36 CIR (87.83 cc/rev)
- 060= 5.84 CIR (95.70 cc/rev)

C: Rear Section Model

- 020= 2.01 CIR (32.94 cc/rev)
- 023= 2.24 CIR (36.65 cc/rev)
- 026= 2.54 CIR (41.60 cc/rev)
- 030= 2.92 CIR (47.77 cc/rev)
- 032= 3.14 CIR (51.49 cc/rev)
- 035= 3.40 CIR (55.70 cc/rev)
- 040= 3.88 CIR (63.63 cc/rev)

D: Rotation

- R= Righthand (CW)
- L= Lefthand (CCW)

E: Seal Kit

- 2= Buna
- 4= Viton

F: Front Drive Gear (Choose One)

- AU= 13T Spline 020
- AR= 13T Spline 023
- AV= 13T Spline 026
- AA= 13T Spline 030
- AX= 13T Spline 032
- AB= 13T Spline 035
- AC= 13T Spline 040
- AD= 13T Spline 045
- AE= 13T Spline 050
- AY= 13T Spline 055
- AZ= 13T Spline 060

F: Front Drive Gear (Continued)

- BA= 15T Spline 020
- AS= 15T Spline 023
- BB= 15T Spline 026
- AF= 15T Spline 030
- BC= 15T Spline 032
- AG= 15T Spline 035
- AH= 15T Spline 040
- AJ= 15T Spline 045
- AK= 15T Spline 050
- BD= 15T Spline 055
- BE= 15T Spline 060

- BF= 1" Straight Key Shaft 020
- AT= 1" Straight Key Shaft 023
- BG= 1" Straight Key Shaft 026
- AL= 1" Straight Key Shaft 030
- BH= 1" Straight Key Shaft 032
- AM= 1" Straight Key Shaft 035
- AN= 1" Straight Key Shaft 040
- AP= 1" Straight Key Shaft 045
- AQ= 1" Straight Key Shaft 050
- BI= 1" Straight Key Shaft 055
- BJ= 1" Straight Key Shaft 060

- BK= .88" Straight Key Shaft 020
- BL= .88" Straight Key Shaft 023
- BM= .88" Straight Key Shaft 026
- BN= .88" Straight Key Shaft 030
- BO= .88" Straight Key Shaft 032
- BP= .88" Straight Key Shaft 035
- BQ= .88" Straight Key Shaft 040
- BR= .88" Straight Key Shaft 045
- BS= .88" Straight Key Shaft 050
- BT= .88" Straight Key Shaft 055
- BU= .88" Straight Key Shaft 060

G: Rear Drive Gear

- B= 020 W/ Auxiliary Drive
- C= 023 W/ Auxiliary Drive
- D= 026 W/ Auxiliary Drive
- 1= 030 W/ Auxiliary Drive
- E= 032 W/ Auxiliary Drive
- 2= 035 W/ Auxiliary Drive
- 3= 040 W/ Auxiliary Drive

CPG (CP 180 Tandem, SAE "B" 4 Bolt Flange, Side Ports), Modular Ordering Code, cont.

H: Rear Cover/Port Code

SAE Code 61 Split Flange, No Inlet, 1.00" Out
 AA= Plain Rear Cover
 AB= LH (CCW) Aux. W/ SAE "A" 2 Bolt 9T
 AC= RH (CW) Aux. W/ SAE "A" 2 Bolt 9T
 BD= LH (CCW) Aux. W/ SAE "A" 2 Bolt 11T
 BE= RH (CW) Aux. W/ SAE "A" 2 Bolt 11T
 AD= LH (CCW) Aux. W/ SAE "B" 2 Bolt 13T
 AE= RH (CW) Aux. W/ SAE "B" 2 Bolt 13T

SAE Code 61 Split Flange, No Inlet, 1.25" Out
 AF= Plain Rear Cover
 AG= LH (CCW) Aux. W/ SAE "A" 2 Bolt 9T
 AH= RH (CW) Aux. W/ SAE "A" 2 Bolt 9T
 BH= LH (CCW) Aux. W/ SAE "A" 2 Bolt 11T
 BJ= RH (CW) Aux. W/ SAE "A" 2 Bolt 11T
 AJ= LH (CCW) Aux. W/ SAE "B" 2 Bolt 13T
 AK= RH (CW) Aux. W/ SAE "B" 2 Bolt 13T

I: Center Section Rotation/Port Code

SAE Code 61 Split Flange Ports
 1= LH (CCW), 2.00" Common Inlet, 1.00" Outlet
 2= RH (CW), 2.00" Common Inlet, 1.00" Outlet
 3= LH (CCW), 2.00" Common Inlet, 1.25" Outlet
 4= RH (CW), 2.00" Common Inlet, 1.25" Outlet

J: Assembly Stud Kit

Combined Displacement*	Combined Displacement*
DT= 040	BJ= 070
DU= 043	BJ= 071
DV= 046	EK= 072
DZ= 049	ED= 073
DW= 050	BK= 075
DX= 052	EE= 076
DX= 053	EE= 077
DY= 055	EE= 078
DY= 056	BL= 080
EA= 058	BL= 081
BG= 060	EF= 082
BG= 061	EF= 083
EB= 062	BQ= 085
EB= 063	EH= 086
EB= 064	EH= 087
BH= 065	BT= 090
EG= 066	EL= 092
EJ= 067	BV= 095
EC= 068	BW= 100

*NOTE: "Combined Displacement" = Equals Sum of Front and Rear Model Codes

Examples: 020+020=040, 050+023=073, and 040+035=075

Notes

Notes



7315 West Wilson Avenue
Harwood Heights, IL 60706
708-867-5400
www.websterproducts.com