

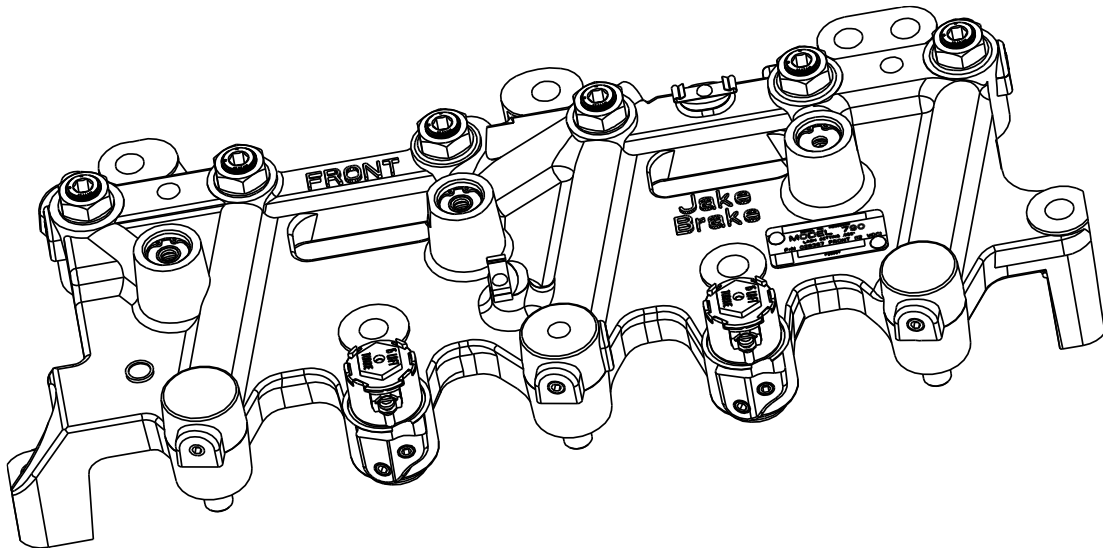

Jacobs Vehicle Systems™

Jacobs Engine Brake™

790/795/797 Series



INSTALLATION MANUAL

Table of Contents

	Page
Section 1: Introduction	4-5
Housing Identification	4
Engine Identification	4
Special Tools	5
Recommended Torque Values	5
Engine Covers	5
Section 2: Engine Preparation	6-7
Series 60 Engines with DDEC IV & V	
Undercover Wire Harness Installation (Retrofit)	6
Section 3: Brake Housing Installation	8-10
Slave Piston Adjustment	10
Section 4: Engine Brake Controls	11
Section 5: Engine Brake Operational Check	12
Rocker Cover Installation	
Section 6: Engine Brake Maintenance	13-19
Theory of Operation	13
Exhaust Blowdown	13
Part Identification	14
Control Valve	15
Slave Piston Adjusting Screw	16
Solid Screw	16
Solenoid Valve	16
Master Piston	17-18
Slave Piston	19

General Information

These instructions describe the installation of the Model 790/795/797 Series Jacobs Engine Brake™, designed for the Detroit Diesel Series 60® engine. For specific application information and slave piston clearance settings, refer to the Jacobs Engine Brake for Detroit Diesel Engines Application Guide, P/N 24770, which can be found on www.jakebrake.com.

For additional information on the 790/795/797 Series engine brakes, refer to the Series 60 Engine Service Manual, P/N 6SE483.

Use OSHA-approved cleaning solvent for cleaning parts. Original parts to be reused should be inspected for wear and replaced as required. Be sure to coat parts with clean engine oil when reinstalling them.

The standard Jacobs Vehicle Systems Warranty applies to the installation of a Jake Brake® Kit. The warranty is administered by Detroit Diesel Corporation. For specific warranty coverages please contact Detroit Diesel.

Safety Precautions

The following symbols in this manual signal conditions potentially dangerous to the mechanic or equipment. Read this manual carefully. Know when these conditions can exist. Then take necessary steps to protect personnel as well as equipment.

 **WARNING** THIS SYMBOL WARNS OF POSSIBLE PERSONAL INJURY.

 **CAUTION** THIS SYMBOL REFERS TO POSSIBLE EQUIPMENT DAMAGE.

NOTE: INDICATES AN OPERATION, PROCEDURE OR INSTRUCTION THAT IS IMPORTANT FOR CORRECT SERVICE.

Fuels, electrical equipment, exhaust gases and moving engine parts present potential hazards that could result in personal injury. Take care when installing equipment or parts. Always wear safety glasses. Always use correct tools and follow proper procedures as outlined in this manual.

NOTE: THE JACOBS ENGINE BRAKE IS A VEHICLE SLOWING DEVICE, NOT A VEHICLE STOPPING DEVICE. IT IS NOT A SUBSTITUTE FOR THE SERVICE BRAKING SYSTEM. THE VEHICLE'S SERVICE BRAKES MUST BE USED TO BRING THE VEHICLE TO A COMPLETE STOP.

NOTE: NEVER REMOVE OR ADJUST ANY ENGINE BRAKE OR COMPONENT WITH THE ENGINE RUNNING.

Section 1: Introduction

Housing Identification

The model, part number, serial number, and adjustment information are located on the nameplate at the top of each housing. (See Fig. 1 and Fig. 2)

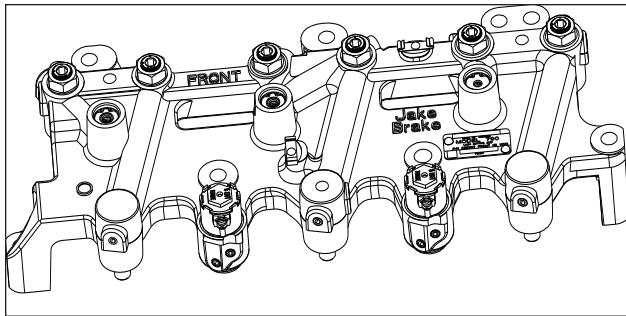

Fig 1

Engine Identification

Engine model identification, serial number and model number, are on the name tag located on the side of the valve cover and stamped on the cylinder block beneath the intake manifold. (See Fig. 3)

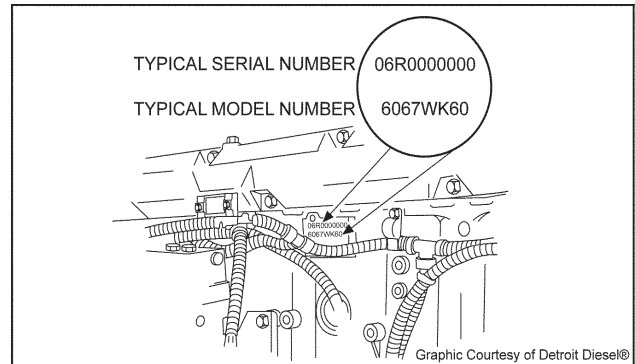

Fig 3



Fig 2

Special Tools

General

18 mm - 12 point Socket
10 mm - 12 point Socket
6" Extension
13 mm Wrench
Retaining Ring Pliers (.047" diameter, 45°)
Diagonal Wire Cutter

Kent Moore

Rocker Shaft Lifting Tool	P/N J-35966A
Stud Torque Socket	P/N J-44706A
Master Piston Assembly Tool (Model 797 Only)	P/N J-45976

Detroit Diesel

Series 60 Engine Service Manual

Jacobs

Feeler Gage, 0.020" (0.508 mm)	P/N 017278
Feeler Gage, 0.026" (0.660 mm)	P/N 017671
Feeler Gage, 0.032" (0.813 mm)	P/N 030504
Control Valve Cover Removal Tool	P/N 016978

Recommended Torque Values

Housing Hold-down Cap Screws	80 lb.-ft. (108 N-m) (lubricated with engine oil)
Rocker Shaft Hold-down Stud	100 lb.-ft. (136 N-m)
Slave Piston Adjusting Screw Locknut	336 lb.-in. (38 N-m)
Solenoid Valve	110 lb.-in. (12.4 N-m)
Slave Piston Spring Shoulder Bolt	200 lb.-in. (23 N-m)

Engine Covers

The engine brake has been designed to fit on the Series 60 engine with no additional valve covers. On engines equipped with a two-piece aluminum valve cover, it is NOT necessary to remove the lower valve cover to install the engine brake. However, one style upper valve cover may require modification at the breather housing location (inside) for engine brake clearance.

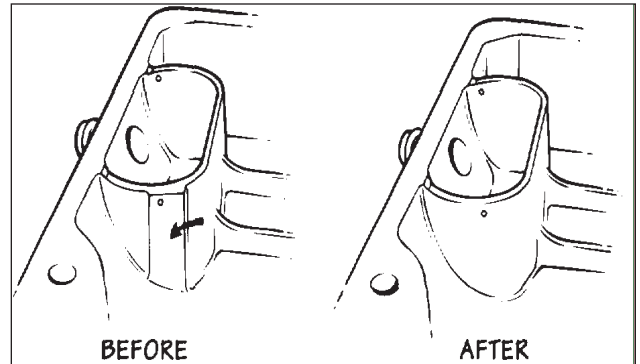

Fig 4

NOTE: IF INTERFERENCE EXISTS BETWEEN THE FRONT ENGINE BRAKE HOUSING AND THE ROCKER COVER CAP AT THE BREATHER HOUSING LOCATION, GRIND THE UPPER COVER TO PROVIDE CLEARANCE. CLEAN COVER THOROUGHLY AFTER GRINDING.

Section 2: Engine Preparation

Series 60 Engines with DDEC IV & V

Access Engine Overhead

1. Disconnect Battery

CAUTION FAILURE TO DISCONNECT BATTERY MAY CAUSE ECM DAMAGE.

2. Thoroughly clean engine
3. Remove valve cover and gasket.

NOTE: IF THE ENGINE HAS A TWO-PIECE COVER, THE LOWER VALVE COVER BASE DOES NOT HAVE TO BE REMOVED.

Exchange Wire Harness

1. Remove existing injector harness & mounting clips from cylinder head.
 - a. Separate wire harness from cylinder head retaining clips.
 - b. Remove 2 harness mounting bolts from rear of cylinder head at head pass through holes. (See Fig. 5)

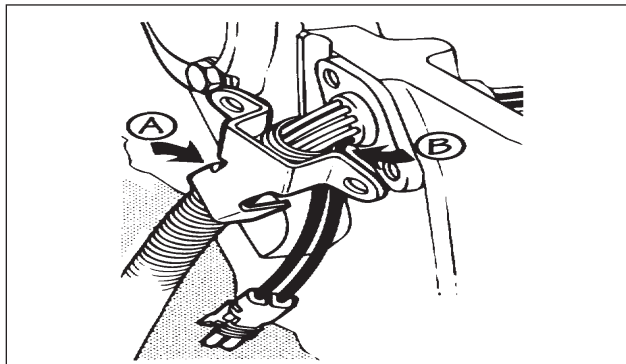

Fig 5

NOTE: FOR ADDITIONAL ACCESS TO REAR CYLINDER HEAD PASS THROUGH, THE ROCKER SHAFTS MAY BE REMOVED USING KENTMOORE TOOL # J35996A

- c. Disconnect 10 pin wire socket located on intake side of cylinder block below number six (6) intake port. (See Fig. 6)

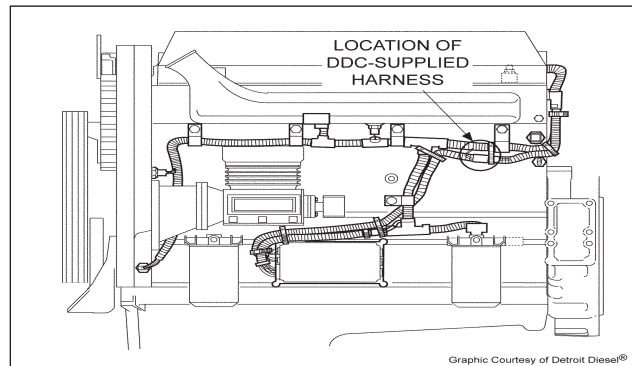

Fig 6

- d. Remove harness by manipulating harness through cylinder head pass through at rear of head.
- e. Remove harness retaining clips from threaded holes in head and discard clips. (See Fig. 7)

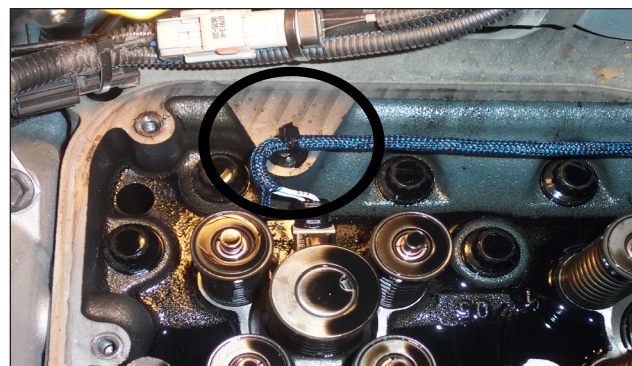

Fig 7

NOTE: REMOVE ENTIRE CLIPS, HOLES WILL BE RE-USED FOR JACOBS SUPPLIED HOUSING HOLD DOWN BOLTS

2. Install new harness P/N 23536019 for on-highway applications or P/N 23534244 for off-highway applications

a. Manipulate harness through rear head pass through. Route harness consistent to previous harness.

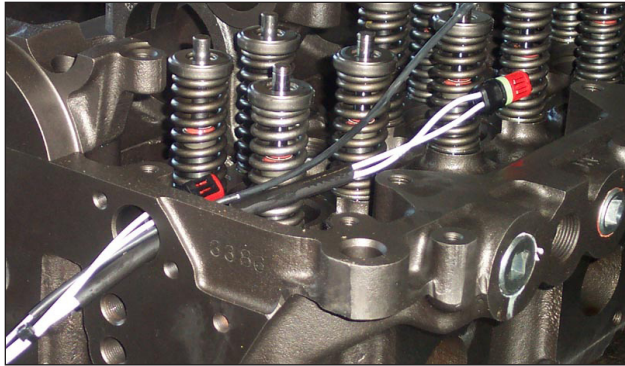
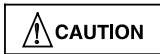

Fig 8



TAKE CARE NOT TO DAMAGE WIRING OR CONNECTORS

b. Connect new harness to injectors.

c. Connect 10 pin wiring socket to main engine harness and secure harness with plastic wire ties as necessary to brake spacer tubes (reference Fig 11 in Section 3 for image).

d. Secure harness at rear head pass through with 2 mounting bolts.

HARNES IS NOW READY FOR JAKE BRAKE INSTALLATION

Section 3: Brake Housing Installation

Install Engine Brake Housings

1. Remove Rocker Shaft Assemblies using 18mm Socket and Kentmoore #J-35996A

NOTE: REMOVING THE OIL FROM THE BOLT HOLES PREVENTS THE CYLINDER HEAD FROM CRACKING WHEN BOLTS ARE TIGHTENED. ATTACH A LENGTH OF TUBING TO AN AIR GUN NOZZLE AND BLOW OUT THE OIL FROM THE ROCKERSHAFT HOLD-DOWN BOLT HOLES. COVER THE HOLES WITH HAND TOWELS TO MINIMIZE OIL SPRAY

WARNING WEAR SAFETY GLASSES WHILE BLOWING THE OIL FROM THE BOLT HOLES.

- a. Remove rocker arm hold down bolts M12x100 mm long (6).
- b. Remove rocker arm nuts at front and rear of head (2).
- c. Retorque rocker shaft studs located at front and rear of cylinder head at 100 lb.-ft. (136 N-m) with Kentmoore tool # J-44706A. (See Fig. 9)

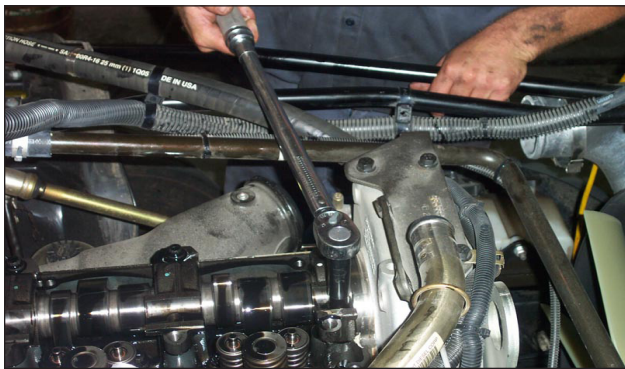

Fig 9

2. Set Rocker Shaft Assemblies back on cam caps.

3. Set front & rear Jake Brake housings on rocker shafts locating on retorqued studs. Ensure that master piston pushrods will engage with pocket located on top of injector rocker arm (see Fig. 10).

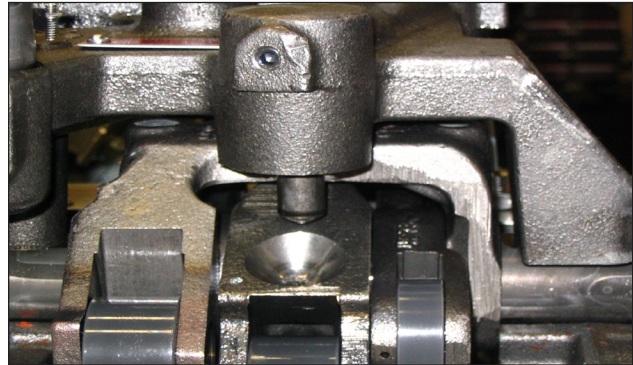

Fig 10

4. Position Jake Brake mounting spacer tubes under outer housing mounting legs. (See Fig. 11)

NOTE: TO PREVENT DAMAGE TO WIRE HARNESS, RUN WIRES INBOARD OF SPACER TUBES AND SECURE TO TUBES USING PLASTIC WIRE TIES.

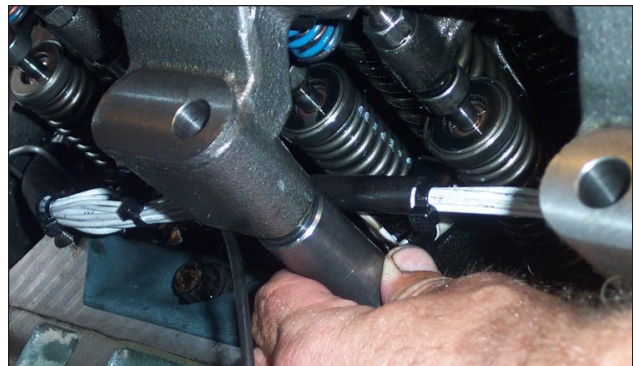

Fig 11

5. Install Jacobs supplied mounting bolts, two lengths, and original DDC stud hex nuts removed earlier. (See Fig. 12)

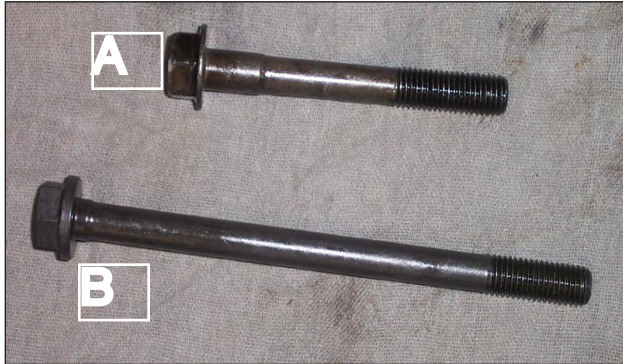

Fig 12

- A - M12x140mm - used on the exhaust side of the engine
- B - M12x170mm - used on intake side (solenoid side) of engine

NOTE: BEFORE TORQUING ENSURE THAT WIRE HARNESS IS INBOARD SO AS TO NOT INTERFERE WITH VALVE COVER

NOTE: BEFORE TIGHTENING HOLD DOWN BOLTS, MOVE THE HOUSING FROM SIDE TO SIDE AND THEN LOCATE HOUSING IN CENTER OF TRAVEL. (SEE FIG. 13)

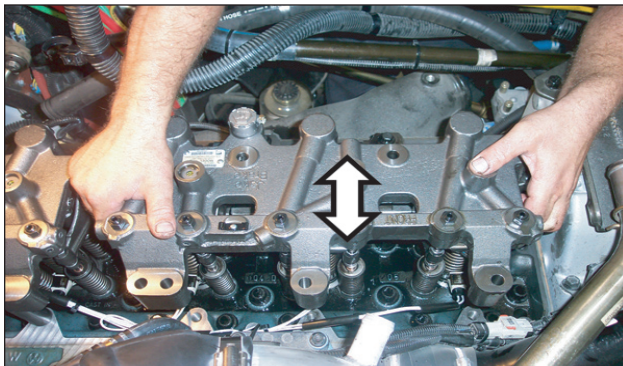

Fig 13

6. Torque down brake housing per sequence in Fig. 14 at 80 lb.-ft. (108 N-m).

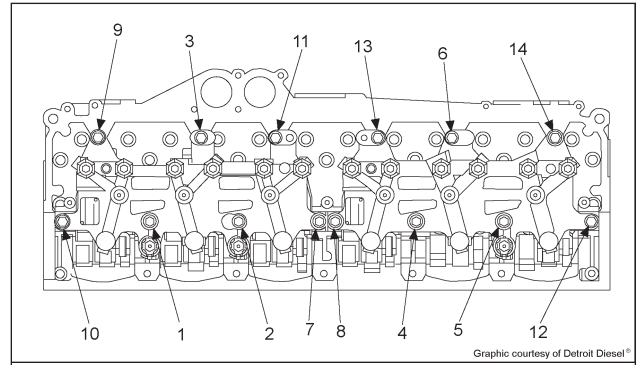

Fig 14

7. Verify exhaust and intake valve lash is still within DDC specifications for engine. If valve lash is out of tolerance, refer to DDC manual for resetting procedure.
8. Attach solenoid wires to solenoid and engage wires in wire retainer clip. (See Fig. 15)

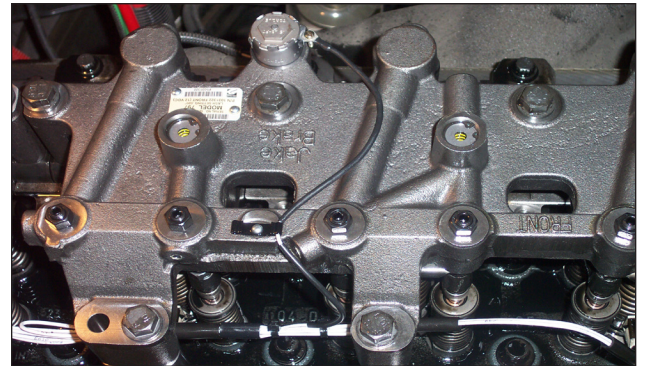

Fig 15

NOTE:

797B APPLICATIONS UTILIZE A DDC WIRE HARNESS TRAY WHICH IS ATTACHED ONTO THE REAR BRAKE HOUSING.

REFERENCE THE DDC SERIES 60 ENGINE SERVICE MANUAL P/N 6SE483 FOR PROPER TRAY TORQUING PROCEDURE

Adjust Slave Piston Clearance

CAUTION FAILURE TO FOLLOW ADJUSTMENT PROCEDURES CAN RESULT IN ENGINE OR ENGINE BRAKE DAMAGE.

NOTE: MAKE SLAVE PISTON ADJUSTMENT WITH THE ENGINE STOPPED AND COLD. ADJUST EACH CYLINDER WITH THE EXHAUST VALVES IN THE CLOSED POSITION.

NOTE: REFERENCE JACOBS APPLICATION GUIDE P/N 24770 FOR PROPER ENGINE AND BRAKE SPECIFIC LASH SETTINGS.

MODEL 790 SERIES

1. Back out the adjusting screws on the slave pistons until the slave piston does not touch the rocker arm adjusting screw.
2. Insert the proper feeler gage (correct adjustment is on housing data tag) between the slave piston and the exhaust rocker adjusting screw. Using a 3/16" (inch) hex wrench, turn in the adjusting screw until the slave piston contacts the exhaust rocker adjusting screw through the feeler gage. Continue turning in the adjusting screw until the valve springs begin to compress, then turn in one (1) additional turn. Wait at least 30 seconds for oil to be purged from the J-Lash adjusting screw.

NOTE: ALL OIL MUST BE PURGED FROM THE J-LASH ADJUSTING SCREW. IF OIL IS BELOW 60 °F, 16 °C, WAIT AT LEAST TWO MINUTES FOR OIL TO BE PURGED FROM THE J-LASH ADJUSTING SCREW.

CAUTION SERIOUS ENGINE DAMAGE MAY OCCUR FROM IMPROPER LASH SETTING.

3. After the time interval specified in step (2), back out the adjusting screw ONLY until a light drag is felt on the feeler gage. Do not retract more than required to obtain a light drag on the feeler gage. Hold the J-Lash adjusting screw in place and torque the lock nut to 38 N•m (336 lb-in).

NOTE: IF THE J-LASH ADJUSTING SCREW IS BACKED OUT UNTIL IT NO LONGER COMPRESSES THE SLAVE PISTON SPRING, OIL WILL ENTER THE SCREW AND THE ADJUSTMENT WILL BE INCORRECT. IF THIS OCCURS, REPEAT STEPS (1) AND (2).

CAUTION OVERTORQUE OF LOCK NUT WILL PROHIBIT PROPER J-LASH OPERATION

4. Recheck lash settings. If lash setting is incorrect, repeat steps (1) through (3) above

NOTE: ONCE THE ENGINE BRAKE HAS BEEN RUN YOU WILL NOT BE ABLE TO CHECK THE ENGINE BRAKE ADJUSTMENT. THIS IS BECAUSE OF OIL RETAINED IN THE J-LASH ADJUSTING SCREW. IF UNSURE OF THE ADJUSTMENT, YOU MUST REPEAT STEPS (1) THROUGH (4) ABOVE.

MODEL 795/797 SERIES

1. Back out the adjusting screws on the slave pistons until the slave pistons do not touch the exhaust rocker arm adjusting screws.
2. Insert the proper feeler gage (correct adjustment is on housing data tag) between the slave piston and the exhaust rocker adjusting screw. Using a 3/16" (inch) hex wrench turn in the adjusting screw until the slave piston contacts the exhaust rocker adjusting screw through the feeler gage, and a drag is felt on the gage.



Fig 16

3. Hold the adjusting screw in place and torque the lock nut to 38 N•m (336 lb-in). Recheck lash settings. If lash setting is incorrect, repeat steps (1) through (3) above.

Section 4: Engine Brake Controls

Series 60 Engines with DDEC IV & DDEC V

Jacobs Dash Switch (optional)

(may use in place of VOEM switch)

ON SERIES 60 ENGINES EQUIPPED WITH DDEC IV OR V, THE ENGINE BRAKE IS CONTROLLED BY THE DDEC ECM. USE OF A JACOBS' SUPPLIED CONTROL MODULE IS NOT REQUIRED.

CONTACT YOUR VEHICLE OEM WITH YOUR VEHICLE SERIAL NUMBER FOR BILL OF MATERIALS NEEDED FOR INSTALLATION.

1. Locate an area on the dash for the dash switch group, Jacobs P/N 020035, and drill a 2" hole.
2. Pass the loose wires of the vehicle OEM wire harness through the 2" hole from the back to the front
3. Attach the wire harness to the switch terminals on the switch group p/n 020035.
4. Install the switch assembly with the bracket, lock washers and wing nuts (see Fig. 18).

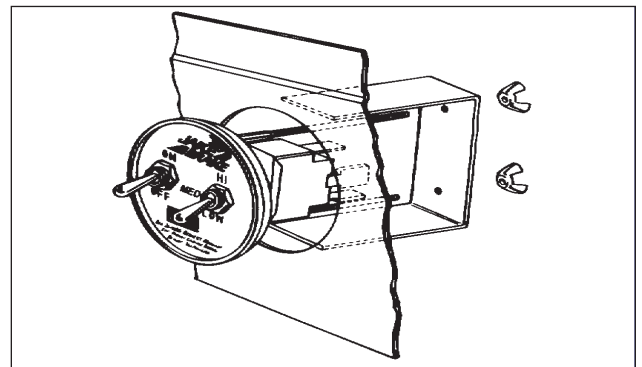

Fig 17

CAUTION DO NOT OVER TIGHTEN NUTS. SWITCH FAILURE COULD RESULT!

NOTE: CONTACT VEHICLE OEM FOR INSTALLATION DETAILS AND WIRING DIAGRAM OF THE WIRING HARNESS AND INTERFACE WITH DASH CONTROL SWITCH.

Section 5: Engine Brake Operational Check

Bleed the engine brake housings

1. Be sure wires are away from moving parts.
2. Start the engine and allow to run for a few minutes.
3. Manually activate the solenoid valve several times to allow the housing to be filled with oil.

NOTE: THE SOLENOID VALVE IS MANUALLY ACTIVATED BY DEPRESSING THE ARMATURE PIN LOCATED IN THE CENTER ON TOP OF THE SOLENOID.

Check for proper operation.

1. Manually activate the solenoid valve and watch the master pistons to be sure they are moving down into the pocket in the injector rocker arm.
2. Watch the slave pistons. They should move down to contact the exhaust valve rocker arm adjusting screws.
3. Check each housing to be sure it is functioning.
4. Shut down engine.

Rocker Cover Installation

One-piece Rocker Cover Installation

1. Install the seal into the groove in the cover and set the cover in place on the cylinder head.
2. Install the four retaining bolts with isolators and washers.
3. Starting with the center bolts and working outward, tighten the bolts to 22 N•m (16 lb-ft).
4. Press the protective plugs into the two center holes.

Two-piece Rocker Cover Installation

1. Make sure the seal is in place in the rocker cover base and set the cover in place on the cover base.

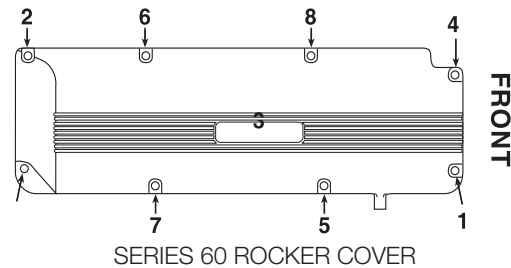

Fig 18

2. Install the bolt with a flat washer, isolator and limiting sleeve into the cover holes.
3. Tighten the bolts to 14 N•m (10 lb-ft) in the sequence shown in Fig. 1.
4. Torque the bolts to 27 N•m (20 lb-ft).

Road Test the Vehicle.

1. Road test the vehicle. The engine brake should come on when the switch is in the ON position, the clutch is engaged and no throttle is being applied.

Section 6: Engine Brake Maintenance

Theory of Operation

Energizing the engine brake effectively converts a power-producing diesel engine into a power-absorbing air compressor. This is accomplished through motion transfer using a master-slave piston arrangement which opens cylinder exhaust valves near the top of the normal compression stroke, releasing the compressed cylinder charge to exhaust.

The blowdown of compressed air to atmospheric pressure prevents the return of energy to the engine piston on the expansion stroke. The effect of this action is a net energy loss, since the work done in compressing the cylinder charge is not returned during the expansion process.

Exhaust Blowdown

Referring to the schematic drawing below, exhaust blowdown occurs as follows:

1. The energized solenoid valve (A) permits engine lube oil (B) to flow under pressure through the control valve (C) to both the master piston (D) and the slave pistons (E).
2. Oil pressure causes the master piston to move down, coming to rest in the injector rocker arm recess (pocket).

3. The injector rocker arm begins its travel as in the normal injection cycle, moving the master piston upward and directing high pressure oil to the slave piston. The ball check valve in the control valve imprisons high pressure oil in the master-slave piston system.
4. High pressure oil causes the slave pistons to move down, momentarily opening the exhaust valves (F), while the engine piston is near its top dead center position, releasing compressed air to the exhaust manifold.
5. Compressed air escapes to the atmosphere, completing a compression braking cycle.

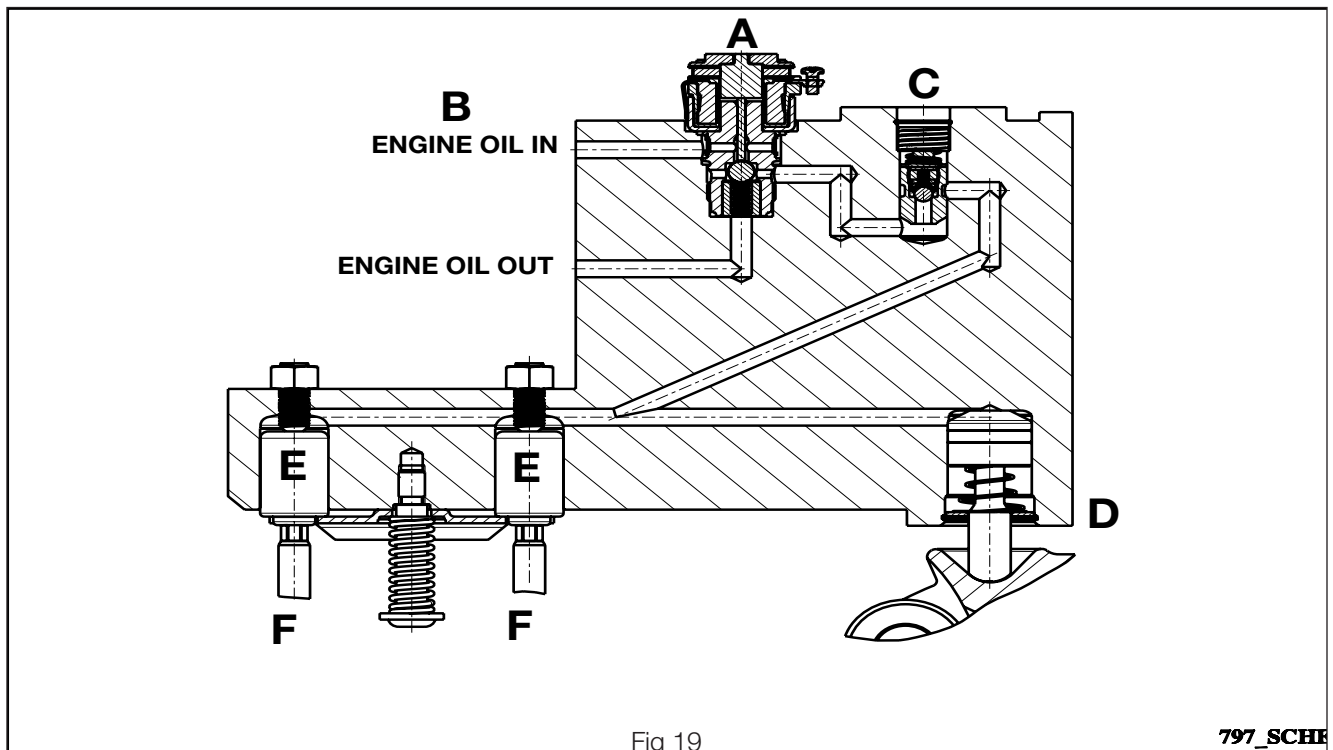

Fig 19

797_SCH

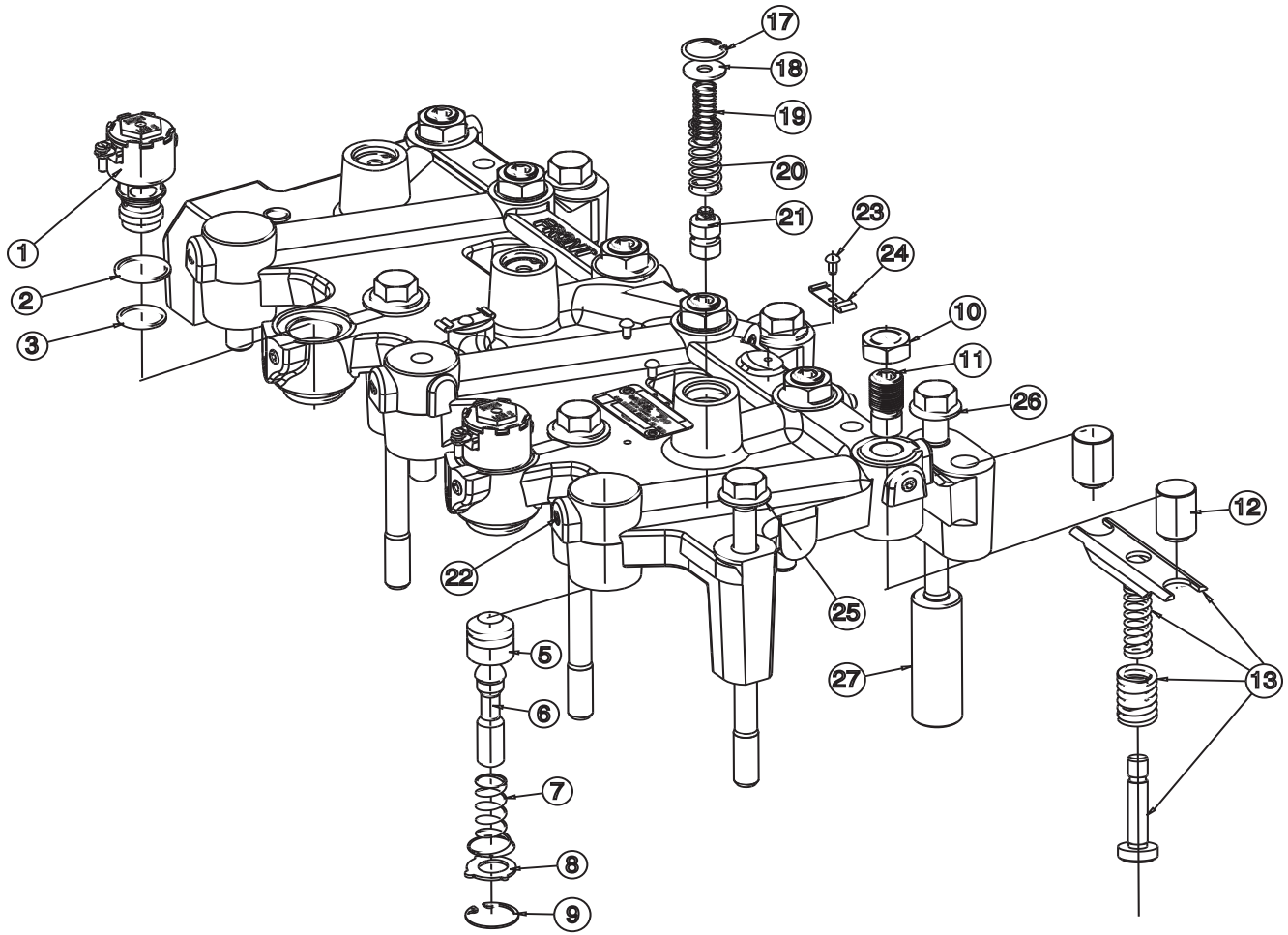

Fig 20



WARNING

NEVER REMOVE ANY ENGINE BRAKE COMPONENT WITH ENGINE RUNNING. PERSONAL INJURY MAY RESULT

The Jacobs Engine Brake is typically a trouble-free device. However, inspections are necessary and some maintenance is required. Use the following procedures to keep the engine brake in top condition.

This section covers how to properly remove, clean and reinstall engine brake components. Use an OSHA-approved cleaning solvent when washing parts. Be sure to coat parts with clean engine oil when reinstalling them.

PARTS LISTING

- 1 Solenoid Valve
- 2 Seal, Solenoid Upper
- 3 Seal, Solenoid Center
- 5 Master Piston
- 6 Master Piston Pushrod
- 7 Master Piston Spring
- 8 Master Piston Retainer
- 9 Spirolox Ring (797)
- 9 Snap Ring (790/795)
- 10 Adjusting Screw Lock Nut
- 11 Solid Screw (795/797)
- 11 J-Lash (790)
- 12 Slave Piston
- 13 Slave Piston Spring Group
- 17 Retaining Ring
- 18 Washer
- 19 Inner Control Valve Spring
- 20 Outer Control Valve Spring
- 21 Control Valve
- 22 Pipe Plug
- 23 Drive Screw
- 24 Wire Harness Clip
- 25 Cap Screw
- 26 Cap Screw
- 27 Spacer Tube

Control Valve



REMOVE CONTROL VALVE COVERS CAREFULLY. CONTROL VALVE COVERS ARE UNDER LOAD FROM THE CONTROL VALVE SPRINGS. REMOVE WITH CARE TO AVOID PERSONAL INJURY.

1. Press down on control valve washer using the control valve cover removal tool, Jacobs p/n 16978 to relieve spring pressure (See Fig. 21)

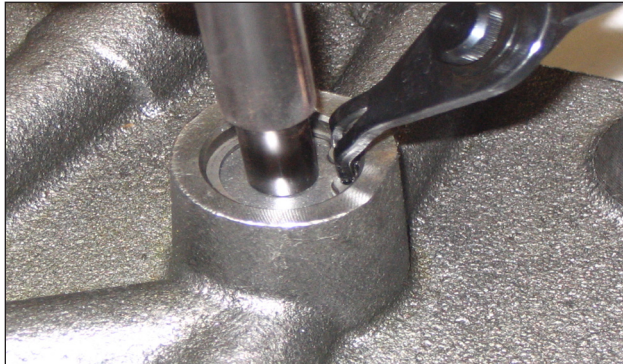

Fig 21

2. Remove retaining ring using retaining ring pliers (See Fig. 21).
3. Slowly remove cover until pressure ceases, then remove the two control valve springs.
4. Using needle-nose pliers, reach into the bore and grasp the stem of the control valve. Remove the control valve.

5. Wash the control valves with approved cleaning solvent. Push a wire through the hole in the bottom of the valve to insure that the ball check is free (see Fig. 22). The ball should lift with light pressure on the wire. If the ball is stuck in the valve, the control valve should be replaced. Dry the valve with compressed air and wipe clean with a paper towel.

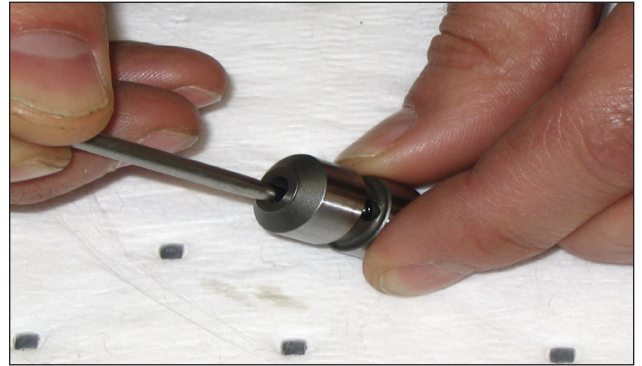

Fig 22

6. Thoroughly clean the control valve bore in the housing using clean paper towels.
7. Dip the control valves in clean lube oil. Holding the valve by the stem, guide it into the bore then allow the valve to descend to the bottom of the bore by its own weight. If binding occurs, the control valve should be replaced. Reassemble parts reversing the removal procedure. Be sure retaining ring ears are rotated 90° (degrees) after installation to ensure full engagement.

Slave Piston Adjusting Screw

MODEL 790 SERIES

1. Loosen the slave piston adjusting screw locknut and remove the J-Lash adjusting screw from the housing. Clean in approved cleaning solvent.
2. Inspect the J-Lash assembly to assure the plunger is retained in the screw body, by pulling on the plunger with fingers. The plunger should retract smoothly and completely under pressure if not replace entire assembly.

NOTE: A MODERATE TO HEAVY SPRING FORCE WILL BE PRESENT BEHIND THE PLUNGER IF OIL IS STILL TRAPPED IN THE ASSEMBLY.

3. Place the J-Lash assembly into the slave piston adjusting screw bore and replace adjusting screw locknut.

NOTE: DO NOT EXCEED LOCKNUT TORQUE. THIS WILL HINDER PLUNGER MOVEMENT AND CAUSE ENGINE BRAKE PERFORMANCE PROBLEMS.

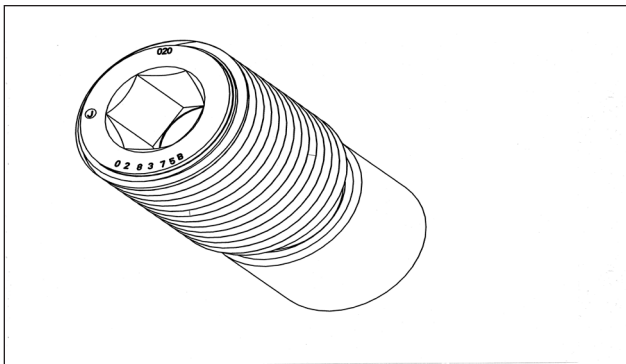

Fig 23

Solid Screw

MODEL 795/797 SERIES

1. Remove the solid screws.
2. Clean the solid screws in approved cleaning solvent. Inspect for excessive wear or damage. Replace if necessary.

Solenoid Valve



DO NOT DISASSEMBLE OR TAMPER WITH THE SOLENOID VALVE. ENGINE DAMAGE COULD RESULT.

1. Disconnect solenoid valve harness. Using 3/4" socket and extension, unscrew solenoid valve.
2. Remove and discard the two rubber seal rings. If the rings stay in the housing bore, remove with a piece of wire.
3. Wash out the solenoid valve with approved cleaning solvent. Use a brush to clean the oil screen. Rise the solenoid valve in cleaning solvent.
4. Clean out the solenoid valve bore in the housing. Use clean paper towels. Never use rags, as they may leave lint and residue which can plug the oil passageways.
5. Coat new solenoid valve seal rings with clean lube oil. Install the seal rings onto the solenoid valve body. Be careful not to twist the seal while installing.

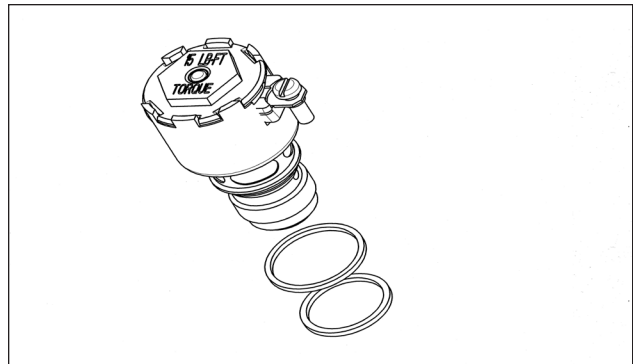

Fig 24

6. Be sure the seals are seated properly. Carefully screw the solenoid valve into the housing without unseating the seals. Torque the valve to 110 lb.-in. (12.4 N-m).

Master Piston

MODEL 790/795 SERIES

1. Compress master piston retainer and remove snap ring using retaining ring pliers (.047" diameter, 45°). (See Fig. 25)



REMOVE SNAP RING CAREFULLY. MASTER PISTON IS UNDER LOAD FROM THE SPRING. REMOVE WITH CARE TO AVOID PERSONAL INJURY.



Fig 25

2. Remove master piston pushrod, retainer, spring and master piston.
3. Clean the master piston in approved cleaning solvent. Inspect for excessive wear or damage. Replace if necessary. Inspect the master piston bore. Some wear marks are permissible. Apply clean lube oil to the piston and insert into bore. Master piston should move in and out freely with no binding. If binding occurs, replace master piston and/or housing.
5. Reassemble the master piston, pushrod, spring, and retainer in housing. Be sure to rotate snap ring 90° (degrees) after installation.

NOTE: THE SPRING SHOULD HOLD THE MASTER PISTON COMPLETELY IN THE HOUSING. IF NOT, THE SPRING HAS RELAXED AND MUST BE REPLACED.

NOTE: THE SMALLER DIAMETER END OF THE SPRING ENGAGES TO THE MASTER PISTON PUSHROD BALL END. SPRING MUST NOT EXPAND OVER BALL END.

MODEL 797 SERIES

1. Use mechanic's pick to wedge screwdriver blade beneath spirolox ring (See Fig. 26).

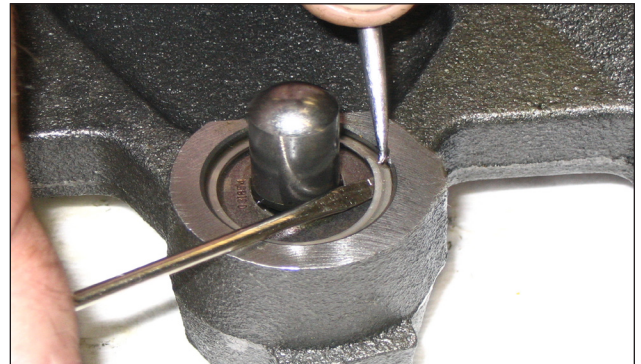

Fig 26

2. Rotate screwdriver around diameter to unwind spirolox. Remove and discard spirolox ring - it cannot be reused (See Fig. 27).



REMOVE SNAP RING CAREFULLY. MASTER PISTON IS UNDER LOAD FROM THE SPRING. REMOVE WITH CARE TO AVOID PERSONAL INJURY.

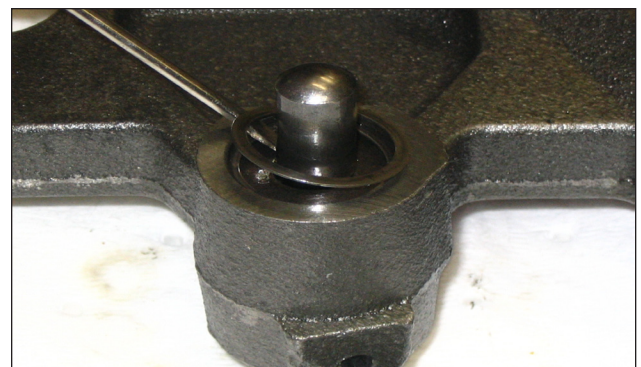

Fig 27

3. Remove master piston pushrod, retainer, spring and master piston.
4. Clean the master piston in approved cleaning solvent. Inspect for excessive wear or damage. Replace if necessary. Inspect the master piston bore. Some wear marks are permissible. Apply clean lube oil to the piston and insert into bore. Master piston should move in and out freely with no binding. If binding occurs, replace master piston and/or housing.

5. Reassemble master piston, pushrod, spring, retainer, and spirolox ring in housing using master piston assembly tool J-45976. (See Fig. 28)

NOTE: WHEN PLACING RETAINER INTO BORE
- PART NUMBER SHOULD BE VISIBLE.



Fig 28

- a. Load spirolox into tapered ring. (See Fig. 29)



Fig 29



Fig 30

- b. Engage master piston assembly tool into bore. Ridge will engage with bore chamfer.
- c. Push down on spirolox until it snaps into place. (See Fig. 31)



Fig 31

NOTE: THE SPRING SHOULD HOLD THE MASTER PISTON COMPLETELY IN THE HOUSING. IF NOT, THE SPRING HAS RELAXED AND MUST BE REPLACED.

NOTE: THE SMALLER DIAMETER END OF THE SPRING ENGAGES TO THE MASTER PISTON PUSHROD BALL END. SPRING MUST NOT EXPAND OVER BALL END.

Slave Pistons

1. Remove slave piston shoulder bolts.

NOTE: SPRING PRESSURE WILL BE RELEASED AS BOLT IS REMOVED. THERE WILL BE NO SPRING PRESSURE REMAINING PRIOR TO BOLT BEING COMPLETELY DISENGAGED.

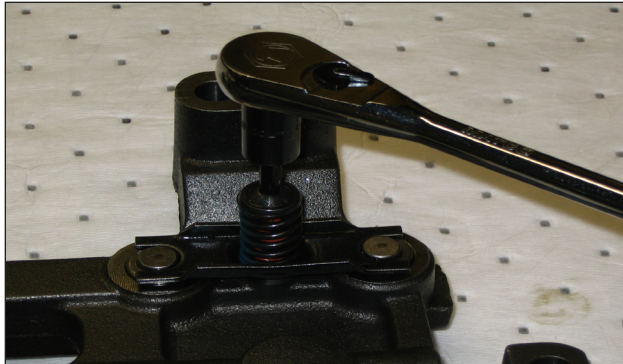

Fig 30

2. Remove springs, bridge, and slave pistons.
3. Clean the slave pistons in approved cleaning solvent. Inspect for excessive wear or damage. Replace if necessary.
4. Ensure slave piston bore has no burrs or ridges, if so remove with a machinist deburring tool. Do not hone the slave piston bore. Removal of too much material will reduce braking performance.
5. Reassemble components. Torque shoulder bolt 200 lb.-in. (23 N-m).

 **CAUTION** OVERTORQUE WILL FRACTURE BOLT.

