

# SECTION 12

## SPECIAL EQUIPMENT

### CONTENTS

Air Compressor ..... 12.4

# AIR COMPRESSOR

The air compressor (Fig. 1) may be mounted on a bracket attached to the cylinder block of the engine and belt-driven from the crankshaft pulley, or it may be flange-mounted to the flywheel housing and gear driven by means of an accessory drive attached to a camshaft gear.

A six bolt design air compressor mounting base, mounting bracket and gasket are used on engines equipped with a belt-driven air compressor.

The air compressor runs continuously while the engine is running. While the compressor is running, actual compression of air is controlled by the compressor governor which acts in conjunction with the unloading mechanism in the compressor cylinder block. The governor starts and stops the compression of air by loading or unloading the compressor when the air pressure in the system reaches the desired minimum or maximum pressure.

During the down stroke of each piston, a partial vacuum is created above the piston which unseats the inlet valve and then allows air drawn from the air box in the engine cylinder block or through an intake strainer to enter the cylinder above the piston. As the piston starts the upward stroke, the air pressure on top of the inlet valves, plus the inlet valve return spring force, closes the inlet valve. The air above the piston is further compressed until the pressure lifts the discharge valve and the compressed air is discharged through the discharge line into the reservoir.

As each piston starts its downstroke, the discharge valve above it returns to its seat, preventing the compressed air from returning to the cylinder and the same cycle is repeated.

When the air pressure in the reservoir reaches the maximum setting of the governor, compressed air from the reservoir passes through the governor into the cavity below

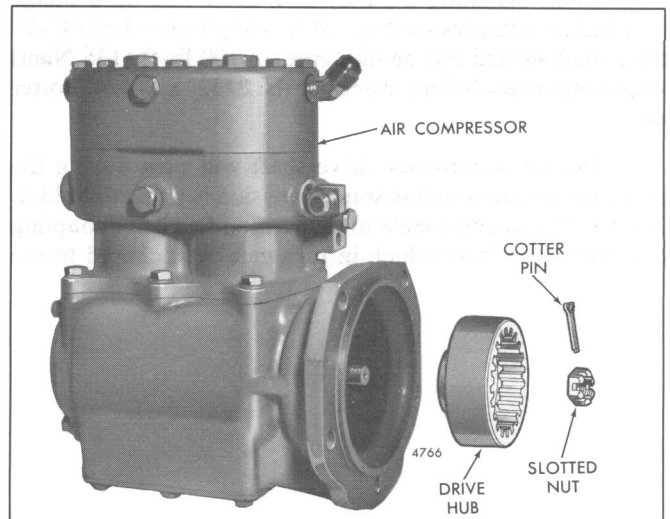

Fig. 2 – Typical Air Compressor with Drive Hub

the unloading pistons in the compressor cylinder block. The air pressure lifts the unloading pistons which in turn lifts the inlet valves off their seats.

With the inlet valves held off their seats, the air during each upstroke of the piston is merely passed back through the air inlet cavity and to the other cylinder where the piston is on the downstroke. When the air pressure in the reservoir drops to the minimum setting of the governor, the governor releases the air pressure beneath the unloading pistons. The unloading piston return spring then forces the piston down and the inlet valve springs return the inlet valves to their seats and compression is resumed.

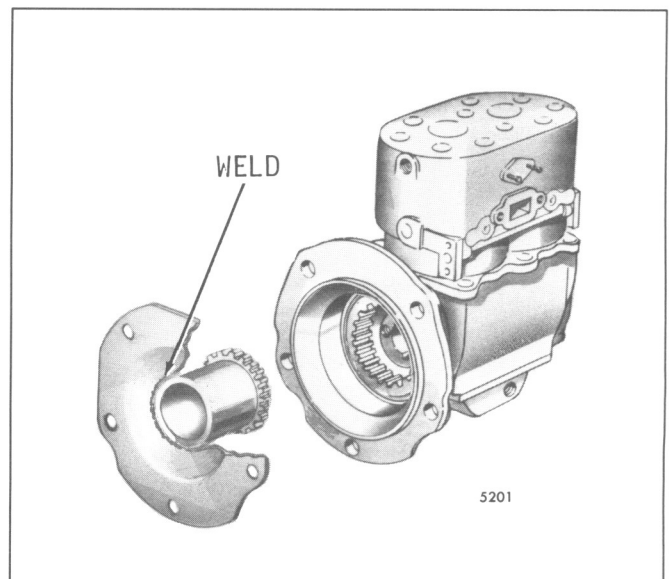
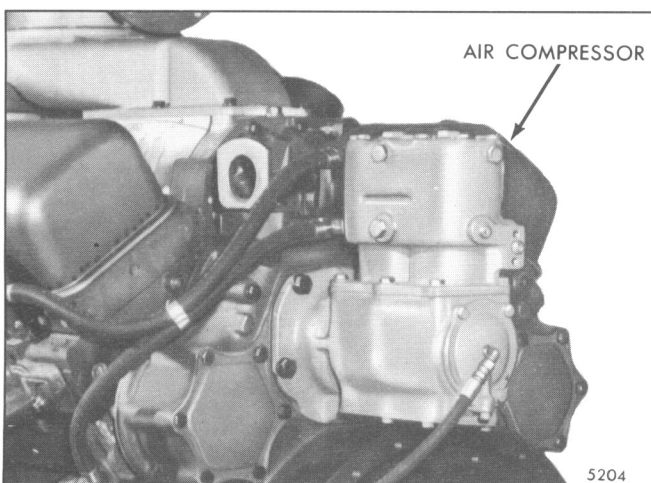

Fig. 3 – Fixture for Holding Drive While Installing or Removing Slotted Nut



1 – Air Compressor Mounting

**Service Note**

When installing a pulley or a drive hub on a flange mounted air compressor (Fig. 2), it is important the  $3/4$ "-16 drive shaft slotted nut be tightened to 100 lb-ft (136 Nm) torque minimum before installing the  $3/32$ " x  $1-1/4$ " cotter pin.

The air compressor drive shaft will turn during the torquing operation unless some provision is made to hold it. One way this can be done is to weld a modified drive coupling to a support or base which in turn can be anchored to the

mounting flange of the compressor. An old flywheel housing cover that matches the flange of the compressor makes an ideal base for the modified coupling. With the exterior splines of the coupling in mesh with the internal splines of the drive hub and the entire assembly secured to the compressor housing, the hub and shaft are kept from rotating when the torque is applied. That part of the base within the inner diameter of the coupling must be removed to permit placement of the wrench socket on the nut. Two bolts will secure the base to the compressor during the torquing operation (Fig. 3).

## SERVICE TOOLS

---

TOOL NAME	TOOL NO.
Air Compressor Hub Remover	J 36309
Air Compressor Hub Installer	J 36311

---