



# OPERATOR'S MANUAL

## HWH COMPUTER-CONTROLLED LEVELING SYSTEM 2000 SERIES

### FEATURING:

*Touch Panel Leveling Control  
Air Leveling  
One or Two Room Extensions  
(With Air Seals)*

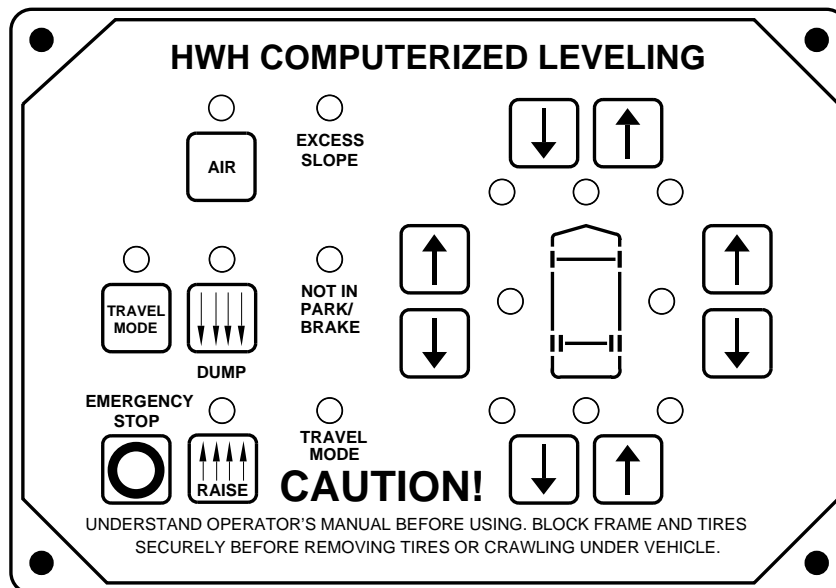

### HWH CORPORATION

(On I-80, Exit 267 South)

2096 Moscow Road | Moscow, Iowa 52760

Ph: 800/321-3494 (or) 563/724-3396 | Fax: 563/724-3408

[www.hwh.com](http://www.hwh.com)

---

# OPERATOR'S MANUAL

---

## CAUTION !

READ THE ENTIRE OPERATOR'S MANUAL BEFORE OPERATING.

BLOCK FRAME AND TIRES SECURELY BEFORE CRAWLING UNDER VEHICLE. DO NOT USE LEVELING JACKS OR AIR SUSPENSION TO SUPPORT VEHICLE WHILE UNDER VEHICLE OR CHANGING TIRES. VEHICLE MAY DROP AND/OR MOVE FORWARD OR BACKWARD WITHOUT WARNING CAUSING INJURY OR DEATH.

KEEP ALL PEOPLE CLEAR OF VEHICLE WHILE LEVELING SYSTEM AND ROOM EXTENSION ARE BEING OPERATED.

NEVER PLACE HANDS OR OTHER PARTS OF THE BODY NEAR HYDRAULIC LEAKS. OIL MAY PENETRATE SKIN CAUSING INJURY OR DEATH.

DO NOT OPERATE THE LEVELING SYSTEM OR USE THE DUMP OR RAISE BUTTONS IF THE VEHICLE IS MOVING IN EXCESS OF 5 MPH.

WEAR SAFETY GLASSES WHEN INSPECTING OR SERVICING THE SYSTEM TO PROTECT EYES FROM DIRT, METAL CHIPS, OIL LEAKS, ETC. FOLLOW ALL OTHER APPLICABLE SHOP SAFETY PRACTICES.

IMPORTANT: IF COACH IS EQUIPPED WITH A ROOM EXTENSION, READ ROOM EXTENSION SECTION BEFORE OPERATING LEVELING SYSTEM.

## HOW TO OBTAIN WARRANTY SERVICE

### THIS IS NOT TO BE INTERPRETED AS A STATEMENT OF WARRANTY

HWH CORPORATION strives to maintain the highest level of customer satisfaction. Therefore, if you discover a defect or problem, please do the following:

**FIRST:** Notify the dealership where you purchased the vehicle or had the leveling system installed. Dealership management people are in the best position to resolve the problem quickly. If the dealer has difficulty solving the problem, he should immediately contact the Customer Service Department, at HWH CORPORATION.

**SECOND:** If your dealer cannot or will not solve the problem, notify the Customer Service Department:  
HWH CORPORATION 2096 Moscow Rd. Moscow IA. 52760  
(563) 724-3396 OR (800) 321-3494. Give your name and address, coach manufacturer and model year, date the coach was purchased, or the date of system installation,

description of the problem, and where you can be reached during business hours (8:00 a.m. till 5:00 p.m. c.s.t.). HWH CORPORATION personnel will contact you to determine whether or not your claim is valid. If it is, HWH CORPORATION will authorize repair or replacement of the defective part, either by appointment at the factory or by the authorization of an independent service facility, to be determined by HWH CORPORATION. All warranty repairs must be performed by an independent service facility authorized by HWH CORPORATION, or at the HWH CORPORATION factory, unless prior written approval has been obtained from proper HWH CORPORATION personnel.

# CONTROL IDENTIFICATION

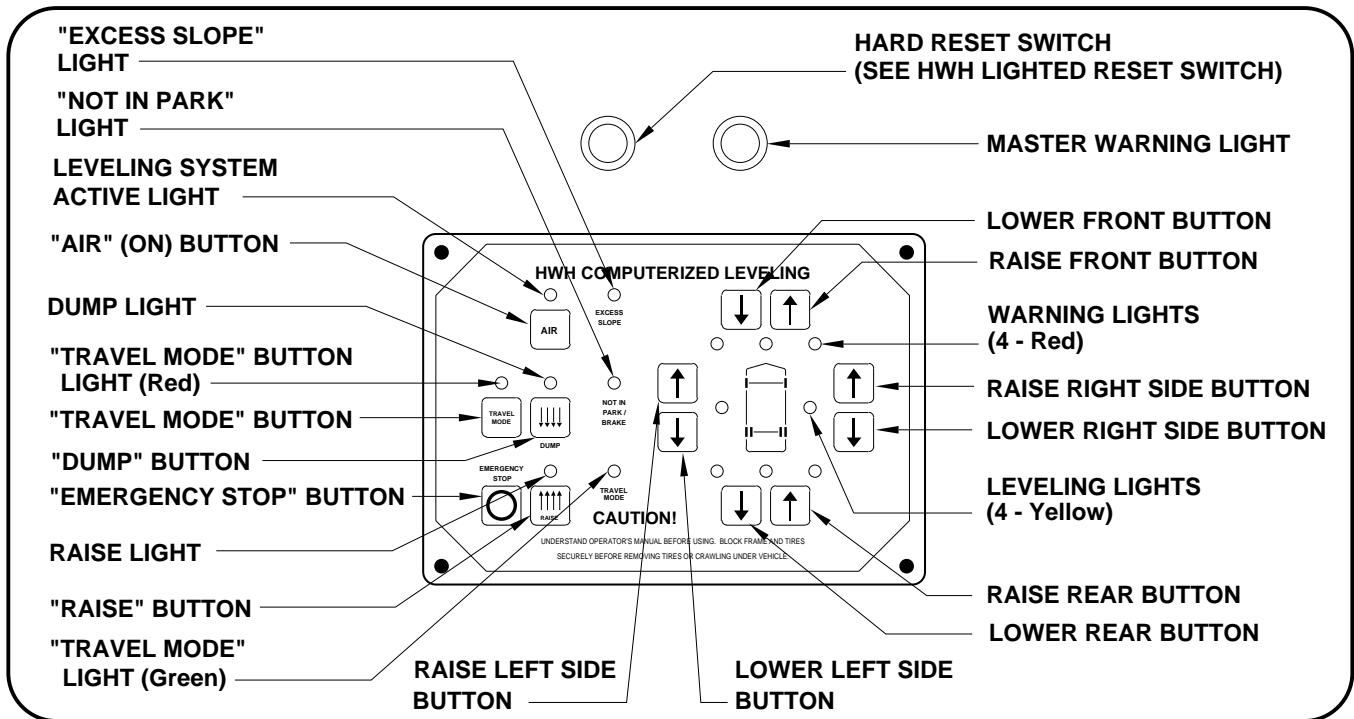

## CONTROL FUNCTIONS

### CONTROL BUTTONS

**"AIR" BUTTON:** This is the system active and automatic operation button. It works if the ignition is in the "ON" position.

**"EMERGENCY STOP" BUTTON:** This button turns the system OFF but does NOT control power to the "DUMP" or "RAISE" buttons. Pushing this button will NOT put the system in the TRAVEL mode.

**"TRAVEL MODE" BUTTON:** This button will put the Leveling System in the TRAVEL mode. The ignition must be "ON" for the vehicle to return to proper ride height for traveling.

**"DUMP" BUTTON:** This button will lower the whole coach by dumping air from the suspension system.

**"RAISE" BUTTON:** This button will raise the whole coach by adding air to the suspension system.

**IMPORTANT:** Read "DUMP AND RAISE FUNCTIONS" before using the "DUMP" or "RAISE" buttons.

**UP ARROWS (RAISE BUTTONS):** These momentary buttons are used for manually operating the air leveling systems. Sides or ends of the vehicle will raise while these buttons are pushed.

**DOWN ARROWS (LOWER BUTTONS):** These momentary buttons are used for manually operating the air leveling systems. Sides or ends of the vehicle will lower while these buttons are pushed.

### INDICATOR LIGHTS

**LEVEL SYSTEM ACTIVE LIGHT:** ON when the system is active, and flashes during automatic leveling.

**DUMP LIGHT:** Flashes when "DUMP" button is pushed.

**RAISE LIGHT:** Flashes when "RAISE" button is pushed.

**"EXCESS SLOPE" LIGHT:** ON if the leveling system can NOT level the coach.

**"TRAVEL MODE" BUTTON LIGHT (RED):** Light flashes for 3 seconds after the "TRAVEL MODE" button is pushed.

**"TRAVEL MODE" LIGHT (GREEN):** ON if the ignition is in the "ON" position, the system is not being used, and there is sufficient air pressure in the suspension. See PREPARATION FOR TRAVEL.

**WARNING LIGHTS:** Function with the ignition in the "ON" position. ON when the LEVELING SYSTEM ACTIVE LIGHT is ON. See PREPARATION FOR TRAVEL.

**LEVELING LIGHTS:** One or two yellow lights can be on indicating the side, end or corner of the coach is low.

**"NOT IN PARK/BRAKE" LIGHT:** ON while the "AIR" button is being pushed if the Park Brake is NOT set. The light will go out when the "AIR" button is released.

**MASTER WARNING LIGHT:** ON any time the "TRAVEL" light is not ON, if the ignition is in the "ON" position.

## CONTROL IDENTIFICATION

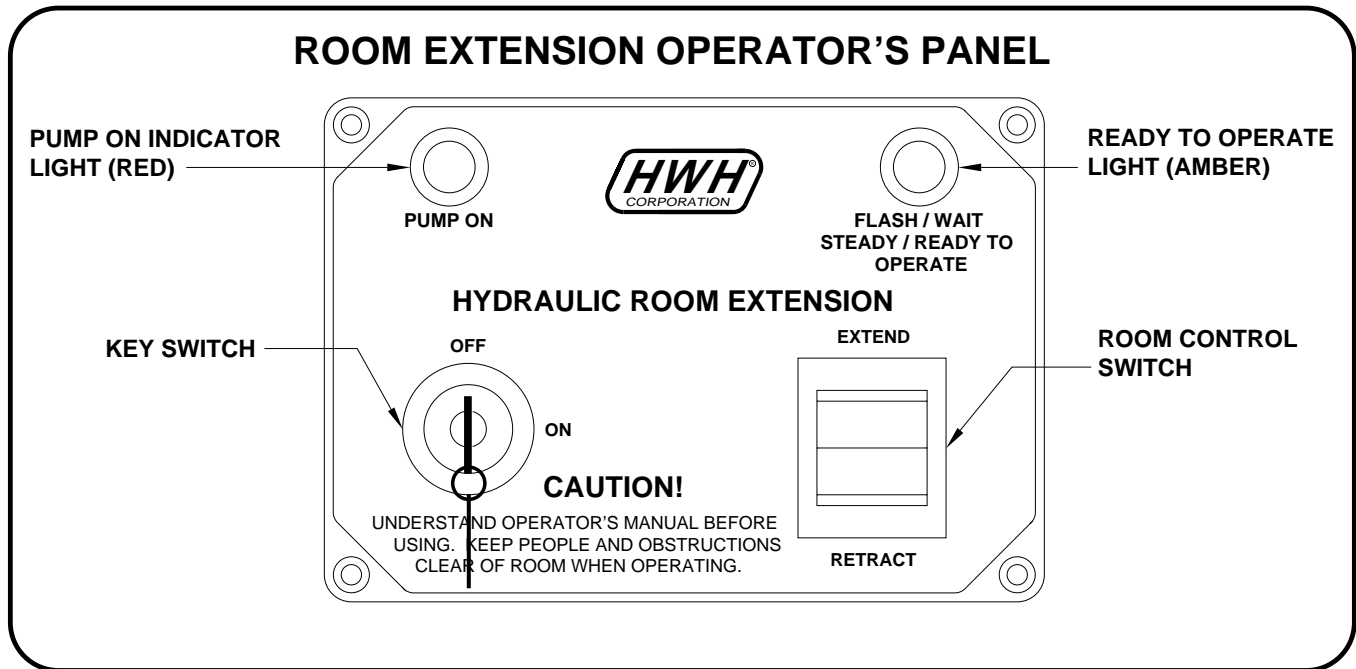

## CONTROL FUNCTIONS

**KEY SWITCH:** The KEY SWITCH controls power to the ROOM CONTROL SWITCH. When the KEY SWITCH is in the "ON" POSITION the room can be operated, and the key cannot be removed. When the KEY SWITCH is in the "OFF" position the room cannot be operated, and the key can be removed.

**NOTE:** Any time the KEY SWITCH is ON, the network will be active and will not power down.

**ROOM CONTROL SWITCH:** The ROOM CONTROL SWITCH is a two position momentary switch. Pressing the switch in the EXTEND POSITION will extend the room. Pressing the switch in the RETRACT POSITION will retract the room. Releasing the ROOM CONTROL SWITCH will halt the operation of the room.

**PUMP ON INDICATOR LIGHT:** This light will be on when the pump is running.

**READY TO OPERATE LIGHT:** This light will flash for 20 seconds while the air seal deflates, after the KEY SWITCH is turned on. It will then glow steady. Except for EXCESS SLOPE situations, the room cannot be extended or retracted if this light is flashing.

If the "EXCESS SLOPE" light on the leveling system control panel is on, the READY TO OPERATE light will flash continuously after the key switch is turned ON. The room will not extend. The room will retract if the room control switch is pushed to "RETRACT".

If the PARK BRAKE is not set, the READY TO OPERATE light will not turn on and flash when the KEY SWITCH is turned "ON".

If a RAISE or LOWER function of the Leveling System is in use, MANUAL or AUTOMATIC operation, the READY TO OPERATE light will flash if the KEY SWITCH is in the "ON" position. The room will not operate.

## MASTER WARNING LIGHT

This light is on the dash, separate from the control panels. It can be on only if the ignition key is in the "ON" position.

The light will be on if a HWH low air pressure switch is on, if the Leveling System is on, if the Leveling System is not in the TRAVEL mode, or if a room in limit switch is not made.

---

# CONTROL IDENTIFICATION

## PUMP RUN TIME

---

### PUMP RUN TIME

Pump motors used with HWH leveling systems and room extension systems come in 3 different diameters; 3", 3.7" and 4.5". Contact the vehicle manufacturer or HWH for help with identifying the motor size. **It is important that any time the pump runs for more than four minutes with a 3" motor; or six minutes with a 3.7" or 4.5" motor that the motor is allowed to cool for thirty minutes before continuing. Continuous operation of the pump motor without allowing the motor to cool can damage the motor.** For cold weather information see "COLD WEATHER OPERATIONS" below.

The HWH systems with a computer processor monitor the pump run time and will turn the pump off if the run time exceeds a specified time. This time can vary with different systems. Due to available electronics or system design, the pump run time programs will also vary. Leveling systems and room extensions that are not controlled by a system processor have no pump run time protection. **DO NOT run the pump more than four or six minutes without allowing the pump motor to cool for thirty minutes.**

#### SYSTEM VARIATIONS FOR PUMP RUN TIME

Some systems with rooms run the rooms separate from the system processor. These systems do not monitor pump run time when operating the rooms. **DO NOT run the pump more than four or six minutes without allowing the pump motor to cool for thirty minutes.**

Some systems can be turned back on immediately after the processor turns the pump off. **DO NOT turn the system back on or run the pump without allowing the pump motor to cool for thirty minutes.**

When operating some leveling systems manually or operating the room extensions, the pump will turn off and back on while pushing the control button when the pump run time has been exceeded. **DO NOT continue without allowing the pump motor to cool for thirty minutes.**

With some systems, when the processor has turned the pump off because the run time has been exceeded, power to the HWH system must be turned off and back on before the system will operate. With motorized vehicles, turn the ignition off and back on. With non-motorized vehicles, turn the master power switch for the HWH system off and back on. **DO NOT continue without allowing the pump motor to cool for thirty minutes.**

Some HWH systems are equipped with a lighted reset switch. If the processor turns the pump off because the run time has been exceeded, the light in the reset switch will turn on. The system will not operate until the reset switch is pushed.

**DO NOT continue without allowing the pump motor to cool for thirty minutes.**

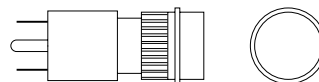

**LIGHTED RESET SWITCH**

**No matter what HWH system is on the vehicle, the pump should not be ran for more than four minutes (3" motors) or six minutes (3.7" or 4.5" motors) without allowing the pump motor to cool for thirty minutes. Continuous operation of the pump motor without allowing the motor to cool can damage the pump motor.**

Contact HWH corporation to get specific information about the system in this vehicle.

## COLD WEATHER OPERATIONS

HWH leveling and room extension systems are designed to function in cold weather down to 0 degrees Fahrenheit. Below freezing (32 degrees Fahrenheit) the jacks or rooms will operate slower than usual.

For operation in temperatures dropping below -20 degrees Fahrenheit, it is necessary that the system is equipped with oil designed for extreme cold weather application such as a synthetic oil. (Contact HWH for recommendations.)

**DO NOT run the pump motor continuously. It is important that any time the pump runs for more than four minutes with a 3" motor; or six minutes with a 3.7" or 4.5" motor that the motor is allowed to cool for thirty minutes before continuing. Continuous operation of the pump motor without allowing the motor to cool can damage the motor.** Continuous operation of the pump with slow moving jacks or rooms in cold weather, without allowing the pump motor to cool will cause the pump motor to burn up and damage the pump assembly.

---

# OPERATING PROCEDURES

---

## NETWORK INFORMATION

The HWH 2000 series CAN system is a computerized modular network. It controls all functions of the leveling system and the room extensions. The network is active any time the ignition is in the "ON" position or when any room extension control panel key is "ON". Certain functions and indicator lights for the leveling system will work when the network is active. Certain functions and lights will work ONLY if the the ignition is in the "ON" position to start the function.

**NOTE: The network will stay active for 10 minutes after the ignition key and all room extension control panel keys have been turned "OFF". If the leveling system was turned "ON", the network will stay active for 10 minutes after automatic leveling is complete or the system goes "EXCESS SLOPE". If manual leveling buttons were used, the network stays active for 10 minutes after the last manual button is released.**

## GENERAL INSTRUCTIONS

Maintain adequate clearance in all directions for vehicles, room extensions, doors, steps, etc.. Vehicle may move in any direction due to raising or lowering of vehicle during leveling, settling of vehicle, equipment malfunction, etc..

The MASTER WARNING LIGHT will be on if an air bag has low pressure or if a room in limit switch is not made, if the ignition is in the "ON" position.

**CAUTION: DO NOT MOVE THE VEHICLE IF A ROOM IS EXTENDED. DO NOT MOVE THE VEHICLE AT SPEEDS IN EXCESS OF 5 MPH IF THE MASTER WARNING LIGHT IS ON.**

The "DUMP" and "RAISE" buttons will function with the leveling system and park brake off, if the ignition is in the "ON" position or if the network is active. See AIR DUMP AND RAISE FUNCTIONS section of this manual.

If the Park Brake is not set, the Leveling System cannot be turned ON and the room extension will not operate.

If a ROOM CONTROL SWITCH is being pushed, no other room or the Leveling System can be operated. If any Leveling System raise or lower function is being operated, no room control switch will work.

## NEUTRAL HOLD OVERRIDE SWITCH

If a room is not fully retracted, the transmission will not shift out of "NEUTRAL".

If the rooms are fully retracted and the transmission will not shift out of NEUTRAL, using a key or a screwdriver turn the HOLD OVERRIDE selector switch to the position labeled

"220" the switch is located on the outside of the Central Control Module. This will allow the transmission to be shifted. The system should be serviced as soon as possible. The HOLD OVERRIDE selector switch should be left in the "110" position for normal operation.

## HWH LIGHTED RESET SWITCH

The HWH lighted reset switch is located on the shifter panel. If there is a failure at any time in the HWH CAN network, the network will shut down. The leveling system and all room extensions will not operate. If the ignition is off, no indicator lights will come on. If the ignition is in the "ON" position, the lighted reset switch and the MASTER WARNING Light will come on.

If the lighted reset switch is on, the switch must be pushed before any room or the leveling system can be operated.

Excessive operation of the hydraulic pump can shut the HWH CAN network down. The lighted reset switch will be on if the ignition is on. The reset button must be pushed before any operation can continue. Allow the pump to cool before continuing hydraulic operations.

A network problem with one room will not inhibit the use of the other rooms or leveling system after the reset switch is pushed.

A network problem with the leveling system will not inhibit the use of the room extensions after the reset switch is pushed.

If the lighted reset switch will not go out when pushed, there is a problem with the central control module of the network system. No rooms or the Leveling System will operate. The vehicle suspension will return to the travel mode if the ignition key is in the "ON" position.

**CAUTION: IF THE IGNITION IS IN THE "ON" POSITION AND THE LIGHTED RESET SWITCH IS ON, THE VEHICLE CAN RETURN TO RIDE HEIGHT WITHOUT RELEASING THE PARK BRAKE.**

---

# OPERATING PROCEDURES

---

## PREPARATION FOR TRAVEL

Check that all room extensions are fully retracted. The green "TRAVEL MODE" light on the touch panel will not be on if a room is extended. The MASTER WARNING light will be ON. (SEE ROOM RETRACT PROCEDURES)

Visually check that the vehicle is at the proper ride height for traveling.

The ignition must be in the "ON" position for the vehicle suspension to be in the travel mode. Also the "TRAVEL MODE" button must be pushed or the park brake released for the suspension to be in the travel mode If the Leveling System was used.

A lit "TRAVEL MODE" light indicates that the HWH Leveling System is in the TRAVEL MODE. It does not indicate that the suspension is at ride height or that the coach is ready to travel.

**CAUTION: IT IS THE OPERATOR'S RESPONSIBILITY TO CHECK THAT THE VEHICLE IS AT PROPER RIDE HEIGHT AND ALL SLIDE-OUTS ARE FULLY RETRACTED BEFORE TRAVELING.**

Before traveling, the MASTER WARNING light must be off and the "TRAVEL MODE" light must be ON.

**NOTE: Low air pressure or an extended room can turn the green "TRAVEL MODE" light off and turn the MASTER WARNING light on.**

Refer to "DUMP" and "RAISE" FUNCTIONS operating procedures when moving the vehicle with the suspension NOT at the proper ride height.

## AUTOMATIC AIR OPERATION

**NOTE: The ignition must be in the "ON" position to use the "AIR" button. Once the operation is started, the ignition can be moved to the "OFF" position and the operation will continue. If a ROOM CONTROL switch is being pushed, the Leveling System can not be operated.**

1. Place the transmission in the proper position for parking and set the park brake. The air leveling system can only be turned on if the ignition is in the "ON" position. Leaving the engine running during leveling is recommended. This will provide a better air supply for leveling. The vehicle will level with the engine shut off, however more time will be required for leveling.

**NOTE: If the ignition key is in the "ON" position, the panel will not turn on if the park brake is not set. The "NOT IN PARK/BRAKE" light will be on while the "AIR" button is being pushed.**

2. Make sure the Tag Lift switch is in the OFF position.

3. Press the "AIR" button once to enter the air mode. The LEVELING SYSTEM ACTIVE LIGHT will glow steady. When the ignition is in the "ON" position, the four red WARNING lights on the panel will come on. This indicates that the height control valves have been locked out. The vehicle should not be moved when these lights are on.

4. Press the "AIR" button a second time. The LEVELING SYSTEM ACTIVE LIGHT will start flashing and air leveling will begin. The system will attempt to level the vehicle by exhausting air from the air bags. If a level position is not achieved by lowering the vehicle, the low side and/or end of the vehicle will be raised by adding air to the air bags. When all four yellow LEVEL SENSING lights are out the leveling is complete.

**NOTE: Only one or two yellow LEVEL SENSING lights may be ON at one time.**

5. When all four yellow level lights are out, the LEVELING SYSTEM ACTIVE LIGHT will stop flashing and start pulsating dimly. The Leveling System is now in the SLEEP MODE. The vehicle's engine/ignition may now be turned OFF.

**NOTE: After the ignition and all room extension KEY SWITCHES are turned OFF, the CAN Network stays active for 10 minutes before shutting down. Leveling System touch panel lights will stay ON during this time and go out when the CAN Network shuts down. If the Leveling System is in the SLEEP MODE when the Network shuts down, the computer will stay ON. The Leveling System touch panel lights will all be OFF, but the Leveling System will still be in the SLEEP MODE.**

6. During the Sleep Mode, after 30 minutes the processor checks the Level Sensing Unit inputs. If no input for a yellow level light is seen, the processor remains dormant and will recheck the level unit inputs every thirty minutes. If a yellow level light input is on for one minute continuously, the processor will relevel the vehicle, then return to the sleep mode.

**NOTE: Touch Panel Lights will not be ON unless the system is actively leveling the vehicle.**

7. If the vehicle needs to be relevelled, the CAN Network will become active. The LEVELING SYSTEM ACTIVE LIGHT will flash. One or two yellow LEVELING LIGHTS will be ON. When the yellow LEVELING LIGHTS are all out, the LEVELING SYSTEM ACTIVE LIGHT will stop flashing and start pulsating dimly. The Leveling System will remain in the SLEEP MODE with the computer monitoring the LEVELING SENSING UNIT every 30 minutes, releveling the vehicle as needed.

---

# OPERATING PROCEDURES

---

## AUTOMATIC AIR OPERATION (Continued)

**NOTE:** The CAN Network will stay active for 10 minutes after releveling the vehicle and then shut down, turning the touch panel lights OFF. This happens every time the system relevels the vehicle.

7. The SLEEP MODE will continue until the "EMERGENCY STOP" button is pushed or the park brake is released, if the ignition is in the "ON" position.

**EXCESS SLOPE:** The system will attempt to level the vehicle for approximately 15 to 20 minutes. After the 15 to 20 minutes, if a LEVEL SENSING light is still on, the "EXCESS SLOPE" light will come on. The LEVEL LIGHT indicator light will go out. The "EXCESS SLOPE" light will be on whenever the network is active.

**NOTE:** Room extensions can not be extended if the "EXCESS SLOPE" light is on but they can be retracted.

The "EXCESS SLOPE" light will be on whenever the network is active until the vehicle is leveled with all yellow LEVEL indicator lights off. Releasing the park brake with the ignition on will turn the "EXCESS SLOPE" light off.



---

# OPERATING PROCEDURES

---

## MANUAL AIR OPERATION

**NOTE: The ignition must be in the "ON" or "ACC" position to use the "AIR" button. Once the operation is started, the ignition can be moved to the "OFF" position and the operation will continue.**

1. Place the transmission in the proper position for parking and set the park brake. The air leveling system can only be turned on if the ignition is in the "ON" position. Running the vehicle engine during leveling is recommended. This will provide a better air supply for leveling. The vehicle will level with the engine shut off, however more time will be required for leveling.

**NOTE: If the "NOT IN PARK/BRAKE" light is on, the leveling system cannot be turned on.**

2. Press the "AIR" button once to enter the air mode. The LEVELING SYSTEM ACTIVE LIGHT indicator light will glow steady. When the ignition is in the "ON" position, the four red WARNING lights on the panel will come on. This indicates that the height control valves have been locked out. The vehicle should not be moved when these lights are on.

3. The vehicle can now be leveled using the RAISE (up arrow) and LOWER (down arrow) buttons on the right half of the

panel in conjunction with the yellow LEVEL indicator lights. **Any side to side leveling should be done, if needed, before leveling the vehicle front to rear.** The yellow LEVEL indicator light indicates that side or end is low. When all yellow lights are out the vehicle is level. Try leveling the vehicle by lowering the high side or end (opposite of the lit yellow level lights). If a level position is not achieved use the RAISE (up arrow) button to raise the low side or end.

**NOTE: In either manual or automatic leveling when either front air manifold air bag pressure switch is on a front lower procedure is halted. When either rear air manifold air bag pressure switch is on, a rear lower procedure is halted. Air bag pressure switches will not interfere with either a right or left lower procedure.**

4. Turn the ignition to the "OFF" position.

5. Turn the system off.

**NOTE: If the "DUMP" or "RAISE" buttons are pushed while manually leveling the vehicle with air and the ignition is in the "ON" position, the system will latch into the dump or raise mode until the "EMERGENCY STOP" button is pushed or the ignition is turned off.**

## "DUMP" AND "RAISE" FUNCTIONS

The "DUMP" and "RAISE" functions are provided for operator convenience for purposes such as dumping the air suspension when parked.

Leave the engine running if the "RAISE" function is to be used. The park brake does not have to be set to use the "DUMP" or "RAISE" buttons.

**IMPORTANT: If the ignition is ON and the park brake is OFF, the "DUMP" and "RAISE" features will latch in and remain on. If the vehicle exceeds 10 MPH, the "DUMP" or "RAISE" functions will automatically turn off and the system will return to the TRAVEL MODE. If the park brake is set, the "TRAVEL MODE" button must be pushed before the vehicle can return to ride height.**

**CAUTION: REREAD CAUTIONS ON THE FIRST PAGE OF THIS MANUAL. THE VEHICLE MAY DROP OR RAISE AND/OR MOVE FORWARD OR BACKWARD WITHOUT WARNING CAUSING INJURY OR DEATH.**

DO NOT OPERATE THE VEHICLE UNLESS THE AIR SUSPENSION IS AT THE PROPER HEIGHT FOR TRAVEL.

The "RAISE" and "DUMP" buttons can be used at any time the network is active. The park brake does not have to be on.

If the ignition is in the "ON" position and the park brake is off, the "RAISE" or "DUMP" buttons will latch in. The vehicle will raise or lower completely and stay in that position.

The vehicle can not return to ride height until the "TRAVEL MODE" button or the "EMERGENCY STOP" button is pushed or the vehicle exceeds 10 M.P.H, putting the system in the TRAVEL MODE.

If the ignition is in the "OFF" position the "RAISE" and "DUMP" buttons will not latch in. The vehicle will remain in the position it was when the button was released. The vehicle can return to ride height when the ignition is turned to "ON" if the park brake is released or the "TRAVEL MODE" button is pushed.

**DO NOT operate the vehicle for extended distances unless the air suspension is at the proper height for travel. The vehicle can not return to ride height until the "EMERGENCY STOP" button is pushed or the vehicle exceeds 10 MPH, putting the system in the TRAVEL MODE.**

**CAUTION: IT IS THE OPERATOR'S RESPONSIBILITY TO CHECK THAT THE VEHICLE IS AT PROPER RIDE HEIGHT BEFORE TRAVELING.**

---

# OPERATING PROCEDURES

---

## ROOM EXTEND PROCEDURE

**IMPORTANT:** It is recommended to level the vehicle before extending the room.

1. The park brake must be set for the room to be operated. If the "EXCESS SLOPE" light on the touch panel is on, the room cannot be extended.

**Make sure the door or a window is open while extending a room.**

**IMPORTANT:** If the "EXCESS SLOPE" light is ON, the vehicle must be re-leveled so all yellow LEVEL indicator lights on the touch panel are OFF before the room can be extended. If any of the four yellow LEVEL indicator lights cannot be put out, the vehicle should be moved to a more level location before using the room extension.

**CAUTION:** KEEP PEOPLE AND OBSTRUCTIONS CLEAR OF ROOM WHEN OPERATING.

**NOTE:** Make sure there is adequate clearance to fully extend the room.

2. Insert the KEY into the KEY SWITCH on the room extension operator's panel and turn it to the "ON" position. The READY TO OPERATE light will flash. When the amber light is on steady the room can be operated.

**NOTE:** Anytime the KEY SWITCH is on, the room air seal will deflate.

**NOTE:** If the Leveling System is being operated, the room will not extend. If the room panel KEY SWITCH is on, the "READY TO OPERATE" light will flash while the Leveling System is being operated.

3. To extend the room, push and hold the ROOM CONTROL SWITCH in the extend position. The red PUMP ON light will come on. There may be a delay of several seconds (no more than 10 seconds) before the PUMP ON light comes on after the switch is pushed. When the room is fully extended, the pump will automatically shut off. The red PUMP ON light will go out. Do not release the ROOM CONTROL SWITCH, until the red PUMP ON light goes out. **If the red PUMP ON light remains on 30 seconds after the room is fully extended release the room control switch.**

**NOTE:** The room is equipped with an air seal, the air seal is monitored by a vacuum switch to make sure the air seal is deflated. This may cause a delay in room operation when the Room Control switch is pushed. While the Room Control Switch is being pushed a loss of vacuum in the air seal will not halt the movement of the room unless the Room Control switch is released. The Room Control switch will not work until the vacuum switch is made.

**NOTE:** Under normal operation of the room, the direction of movement should not be reversed. If the movement of the room must be reversed, do not try to re-extend the room until the room has been fully retracted.

**IMPORTANT:** IF EITHER SIDE OF THE ROOM STOPS MOVING, RELEASE THE ROOM CONTROL SWITCH IMMEDIATELY. THE ROOM OPERATION WILL HALT. DO NOT FORCE THE ROOM. DO NOT REVERSE DIRECTION OF THE ROOM. BINDING OF ROOM CAN CAUSE ROOM DAMAGE. CONTACT HWH CORPORATION CUSTOMER SERVICE FOR ASSISTANCE.

**NOTE:** The READY TO OPERATE light will flash when the room control switch is pushed if the "EXCESS SLOPE" light on the Leveling System panel is ON. The room will not extend.

4. Turn the KEY SWITCH to the "OFF" position and remove the key. The READY TO OPERATE light will go out. The air seal will inflate.

**NOTE:** If the KEY SWITCH is left "ON" the air seal will not inflate and the Network will stay active and not power down.

---

# OPERATING PROCEDURES

---

## ROOM RETRACT PROCEDURE

**CAUTION:** KEEP PEOPLE AND OBSTRUCTIONS CLEAR OF ROOM WHEN OPERATING.

Make sure the door or a window is open while extending a room.

1. The park brake must be set for the room to be operated.

**IMPORTANT:** It is recommended that the coach is level before retracting the room.

2. Insert the KEY into the KEY SWITCH on the room extension operator's panel and turn it to the "ON" position. The air seal will deflate. The READY TO OPERATE light will flash. When the amber light is on steady the room can be operated.

**NOTE:** If the Leveling System is being operated, the room will not retract. If the room panel KEY SWITCH is on, the "READY TO OPERATE" light will flash while the Leveling System is being operated.

3. To retract the room, push and hold the ROOM CONTROL SWITCH in the retract position. The red PUMP ON light will come on. There may be a delay of several seconds (no more than 10 seconds) before the PUMP ON light comes on after the switch is pushed. When the room is fully retracted, the pump will automatically shut off. The red PUMP ON light will go out. Do not release the ROOM CONTROL SWITCH, until the red PUMP ON light goes out. **If the red PUMP ON light remains on 30 seconds after the room is fully retracted release the room control switch.**

**NOTE:** The room is equipped with an air seal, the air seal is monitored by a vacuum switch to make sure the air seal is deflated. This may cause a delay in room operation when the Room Control switch is pushed. While the Room Control Switch is being pushed a loss of vacuum in the air seal will not halt the movement of the room unless the Room Control switch is released. The Room Control switch will not work until the vacuum switch is made.

**NOTE:** Under normal operation of the room, the direction of movement should not be reversed. If the movement of the room must be reversed, do not try to retract the room until the room has been fully extended.

**IMPORTANT:** IF EITHER SIDE OF THE ROOM STOPS MOVING, RELEASE THE ROOM CONTROL SWITCH IMMEDIATELY. THE ROOM OPERATION WILL HALT. DO NOT FORCE THE ROOM. DO NOT REVERSE DIRECTION OF THE ROOM. BINDING OF ROOM CAN CAUSE ROOM DAMAGE. CONTACT HWH CORPORATION CUSTOMER SERVICE FOR ASSISTANCE.

4. Turn the KEY SWITCH to the "OFF" position and remove the key. The READY TO OPERATE light will go out. The air seal will inflate.

**NOTE:** If the KEY SWITCH is left "ON" the air seal will not inflate and the Network will stay active and not power down.

**IN THE EVENT OF THE FAILURE OF THE ROOM TO RETRACT, CONTACT HWH CORPORATION CUSTOMER SERVICE AT 1-800-321-3494 FOR ASSISTANCE.**

# MANUAL ROOM AND GENERATOR SLIDE RETRACT PROCEDURE (WITH SOLENOID VALVES WITH VALVE RELEASE NUTS)

(USE ONLY WHEN THE ROOM WILL NOT RETRACT WITH THE ROOM CONTROL SWITCH)

## OVERVIEW

The room can be retracted manually if a hydraulic or electric failure prevents the room from being retracted using the CONTROL SWITCH. For normal retract sequence see the ROOM SLIDE RETRACT PROCEDURES. Refer to the vehicle manufacturer for storage location of the winch and information for connecting the winch to the room.

**IMPORTANT:** If the vehicle is not equipped with a winch, DO NOT use other pulling devices to retract the room. Follow steps 2 and 3 and try pushing the room in. Contact the vehicle manufacturer or HWH Customer Service at 1-800-321-3494 or 563-724-3396 for assistance.

**CAUTION:** THE MANUAL RETRACT WINCH IS EQUIPPED FOR MANUALLY RETRACTING THE ROOM ONLY. IT IS NOT TO BE USED FOR LIFTING OR ANY OTHER APPLICATION. HIGH FORCES ARE CREATED WHEN USING A WINCH, CREATING POTENTIAL SAFETY HAZARDS. FAILURE TO FOLLOW ALL CAUTIONS AND INSTRUCTIONS MAY CAUSE FAILURE OF THE MANUAL RETRACT WINCH OR CONNECTIONS RESULTING IN DAMAGE OR PERSONAL INJURY. MAINTAIN FIRM GRIP ON THE WINCH HANDLE AT ALL TIMES. NEVER RELEASE THE HANDLE WHEN RATCHET LEVER IS IN THE OFF POSITION AND THE WINCH IS LOADED. THE WINCH HANDLE COULD SPIN VIOLENTLY AND CAUSE PERSONAL INJURY. CHECK THE WINCH AND STRAPS FOR DAMAGE OR WEAR, AND CHECK FOR PROPER RATCHET OPERATION ON EACH USE OF THE WINCH. DO NOT USE IF DAMAGED OR WORN.

1. Retract jacks following the LEVELING SYSTEM RETRACT PROCEDURE.

**NOTE :** When manually retracting the room, make sure the jacks are retracted before retracting the room.

2. Locate the HYDRAULIC PUMP/MANIFOLD unit.

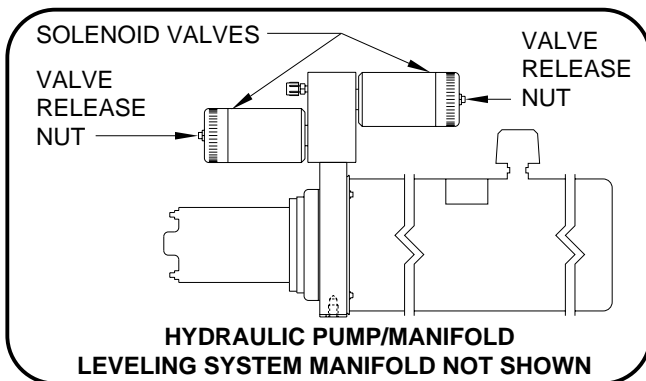

3. Open the Solenoid Valves by slowly turning the valve release nuts counter clockwise using the 1/4" nut driver supplied.

**IMPORTANT:** Only open the valves enough to retract the room. DO NOT turn the release nuts more than 4 and 1/2 turns. Turning the nuts more could damage the valves.

**NOTE:** Prior to APRIL 2002 a 1/4" Nut Driver was sent with the Operators Manual. As of APRIL 2002 the 1/4" Nut Driver has been incorporated into the Breather Cap. See the back page of this manual for further info.

**NOTE:** The room may move slightly as the SOLENOID VALVES are opened and internal pressure is released.

4. Locate the MANUAL RETRACT WINCH and connect it to the room according to the vehicle manufacturer's instructions. To extend the WINCH STRAP firmly grasp WINCH HANDLE, place RATCHET LEVER in its OFF position, and slowly rotate the WINCH HANDLE counter clockwise, keeping a firm grip on the handle. When enough WINCH STRAP is extended, place the RATCHET LEVER in its ON position and slowly rotate the WINCH HANDLE clockwise until the RATCHET LEVER locks.

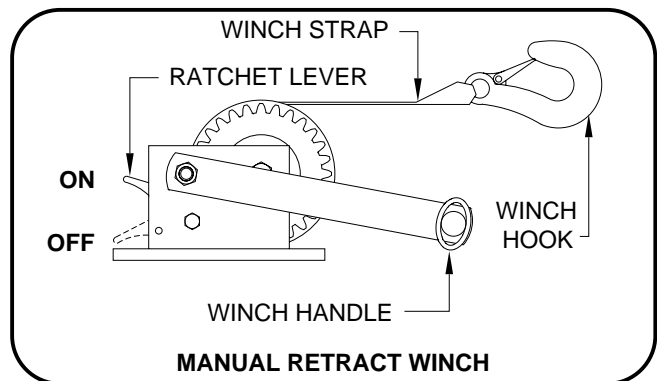

5. Slowly winch the room in by turning the WINCH HANDLE clockwise. The RATCHET LEVER should produce a loud, sharp, clicking noise.

**NOTE:** Winching the room in quickly will raise pressure in the hydraulic fluid and make winching more difficult.

**CAUTION:** OPERATE THE MANUAL RETRACT WINCH BY HAND POWER ONLY. IF THE WINCH CANNOT BE CRANKED EASILY WITH ONE HAND IT IS PROBABLY OVERLOADED. IF WINCHING BECOMES TOO DIFFICULT STOP AND CHECK FOR OBSTRUCTIONS OR RESTRICTIONS ON THE ROOM AND ROOM EXTENSION MECHANISM.

6. When the room is fully retracted, engage the room locking devices. Leave the retract winch engaged and the solenoid valves open.

**CAUTION:** THE ROOM EXTENSION SOLENOID VALVE RELEASE NUTS MUST BE IN THE OPEN POSITION WHEN THE MANUAL RETRACT WINCH IS ENGAGED.

7. The system should be repaired before using again.

**NOTE:** After repairs are made, when closing the VALVE RELEASE NUTS, do not over tighten the nuts.

MP35.952D  
01MAY02

---

# MAINTENANCE

---

## OIL LEVEL

It is important that all front rooms are fully retracted before checking the hydraulic oil level. If the coach has a bed slide, the bed slide must be fully retracted before checking the hydraulic oil level. If the coach has a wardrobe slide, the wardrobe slide must be fully extended before checking the hydraulic oil level. To check the oil supply, remove the breather cap from the top of the hydraulic oil reservoir. The oil level should be approximately one inch below the top of the reservoir when adequately filled.

**FLUID:** HWH Specialty Hydraulic Oil is recommended. In an emergency Dexron automatic transmission fluid can be used.

**NOTE:** Dexron automatic transmission fluid contains red dye and can cause staining should a leak occur. **DO NOT USE** brake fluid or hydraulic jack fluid. Use of these can damage seals.

# HYDRAULIC LINE CONNECTION DIAGRAM FRONT ROOM - LATERAL ARM ROOM EXTENSION (WITH SYNCHRONIZING CYLINDER)

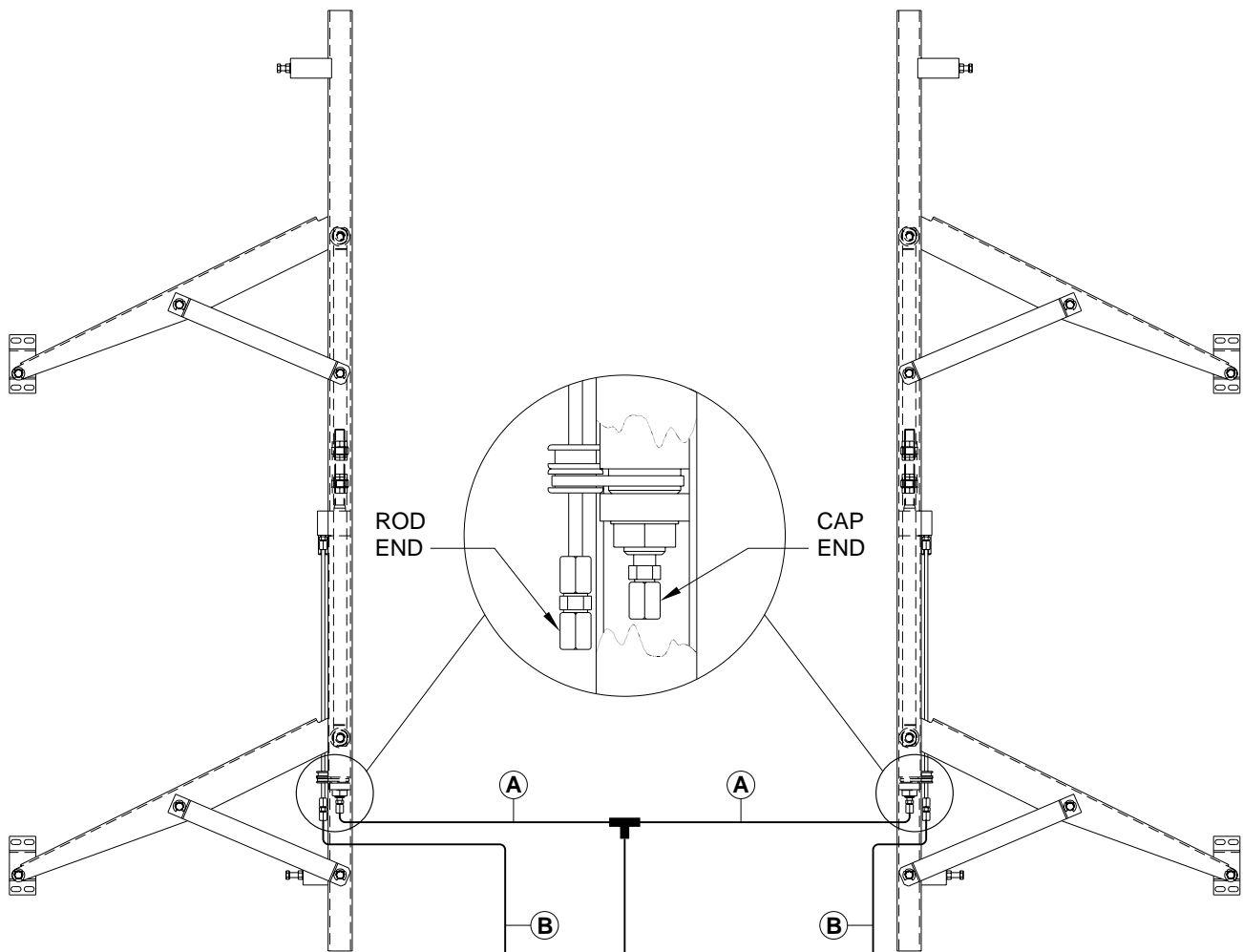

THE LINES (A) BETWEEN THE CAP END OF THE HYDRAULIC ROOM CYLINDERS AND THE TEE MUST BE THE SAME LENGTH AND DIAMETER.

THE LINES (B) BETWEEN THE ROD END OF THE HYDRAULIC ROOM CYLINDER AND THE SYNCHRONIZING CYLINDER MUST BE THE SAME LENGTH AND DIAMETER.

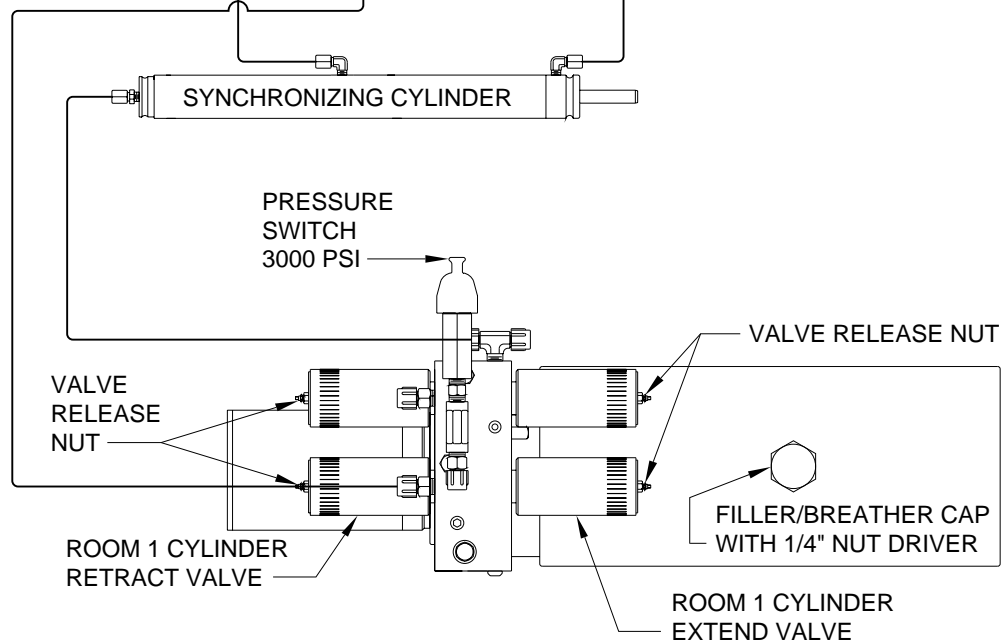

**CYLINDER EXTEND - ROOM EXTEND**  
**CYLINDER RETRACT - ROOM RETRACT**

# HYDRAULIC LINE CONNECTION DIAGRAM WARDROBE - LATERAL ARM ROOM EXTENSION (WITH SYNCHRONIZING CYLINDER)

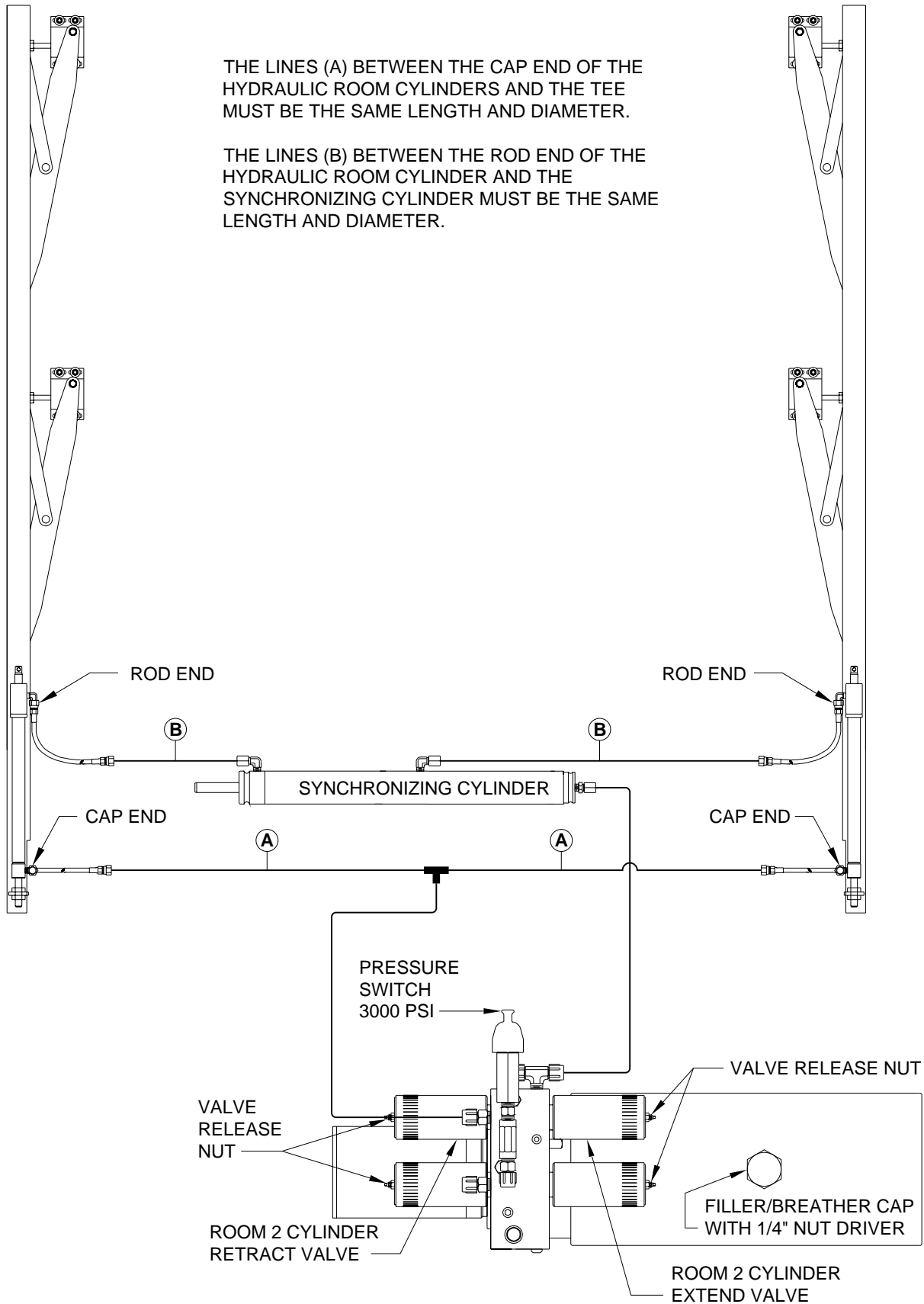

CYLINDER EXTEND - ROOM RETRACT  
CYLINDER RETRACT - ROOM EXTEND

MP65.455C  
12AUG02

**HYDRAULIC FLOW DIAGRAM  
VERTICAL ARM OR DUAL CYLINDER ROOM EXTENSION  
WITH SYNCHRONIZING CYLINDER  
STATIONARY POSITION**

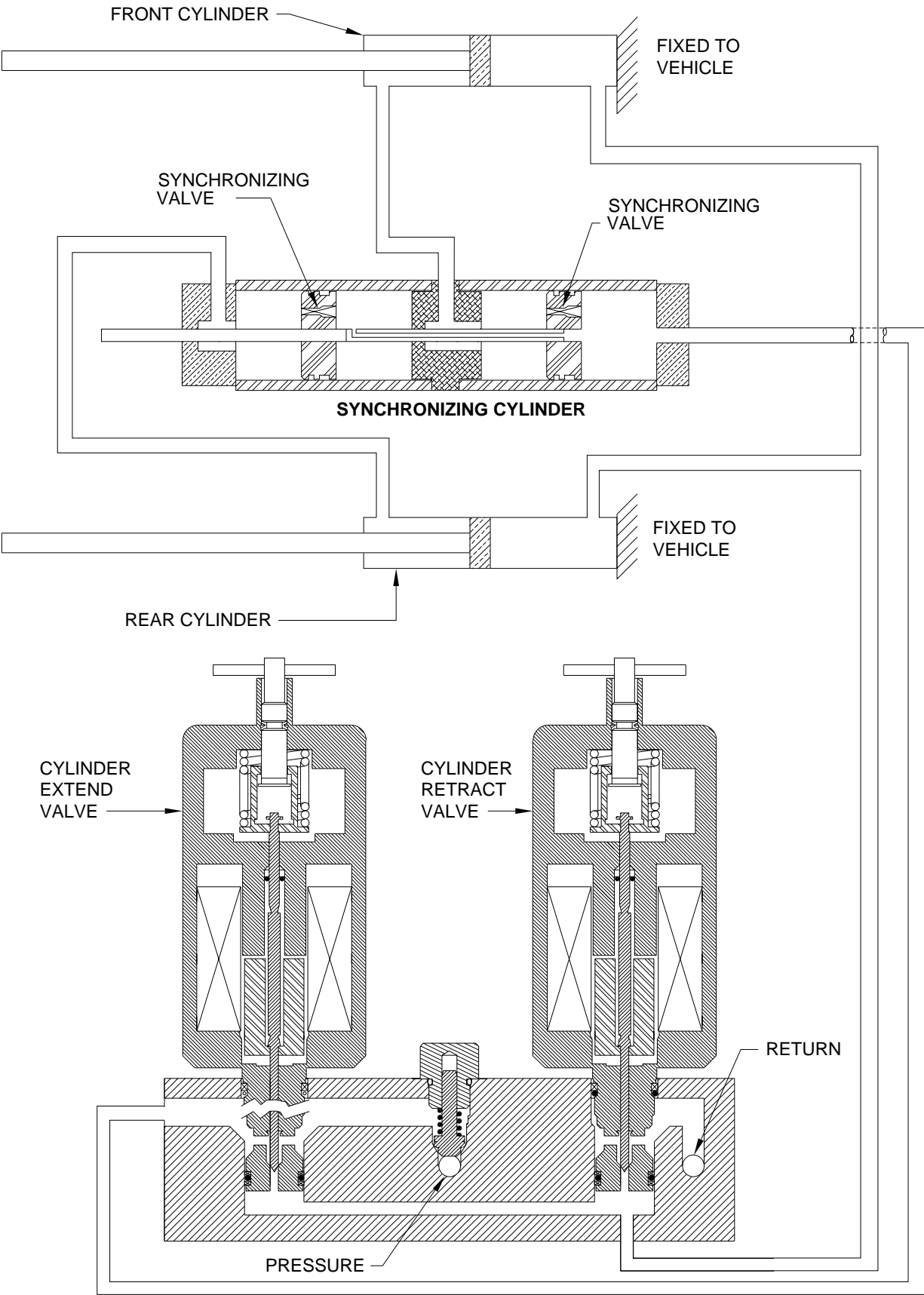



# AIR LINE CONNECTION DIAGRAM FRONT AND DRIVE AXLE

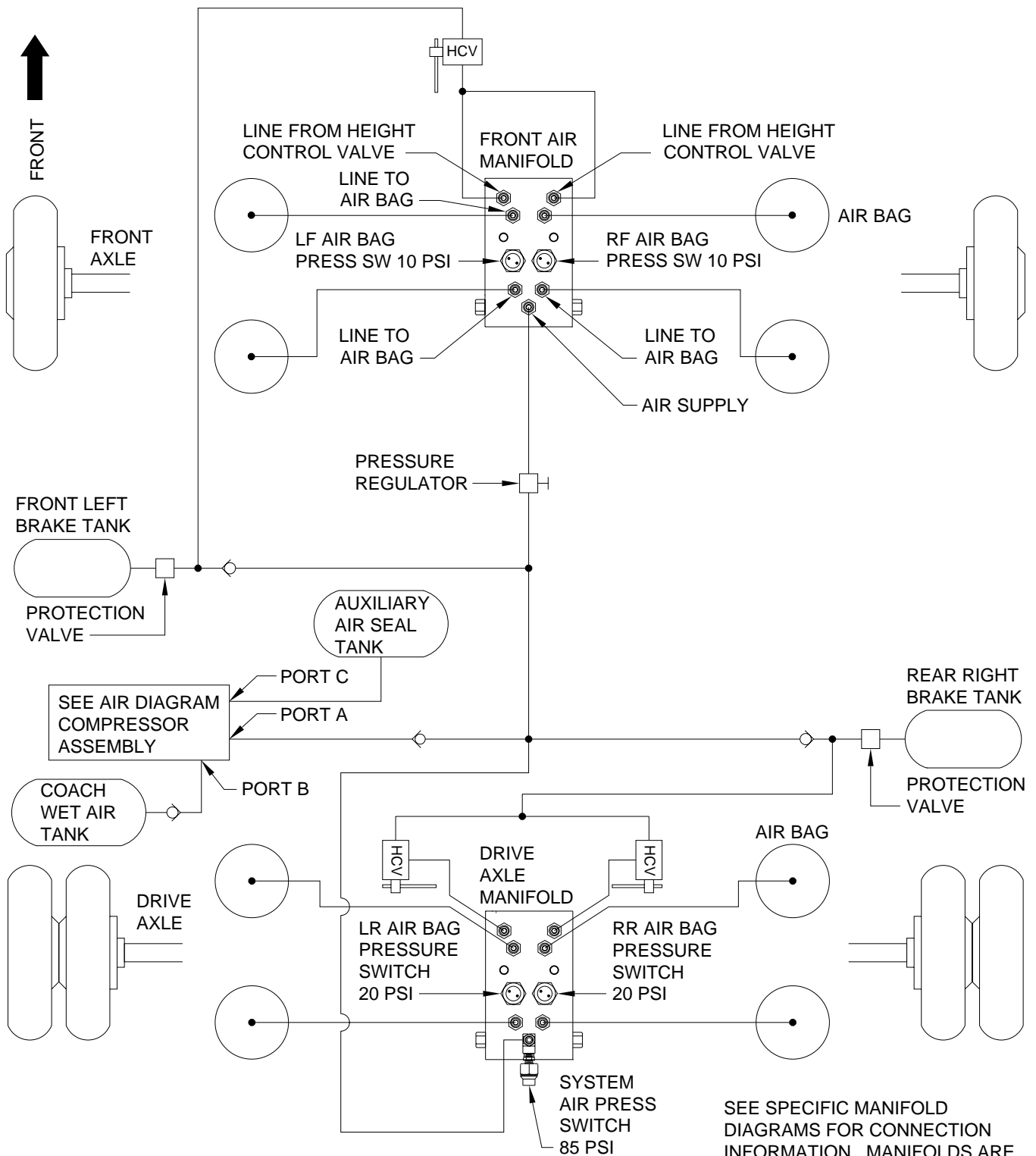

SEE SPECIFIC MANIFOLD DIAGRAMS FOR CONNECTION INFORMATION. MANIFOLDS ARE PRE-WIRED AND CONNECTIONS ARE LABELED. RIGHT AND LEFT CONNECTIONS MUST BE PROPERLY MAINTAINED.

# AIR LEVEL SCHEMATIC - FORETRAVEL

## 4 - POINT LEVELING WITH TAG AXLE

### PRESSURE SWITCHES FRONT AND DRIVE AXLE

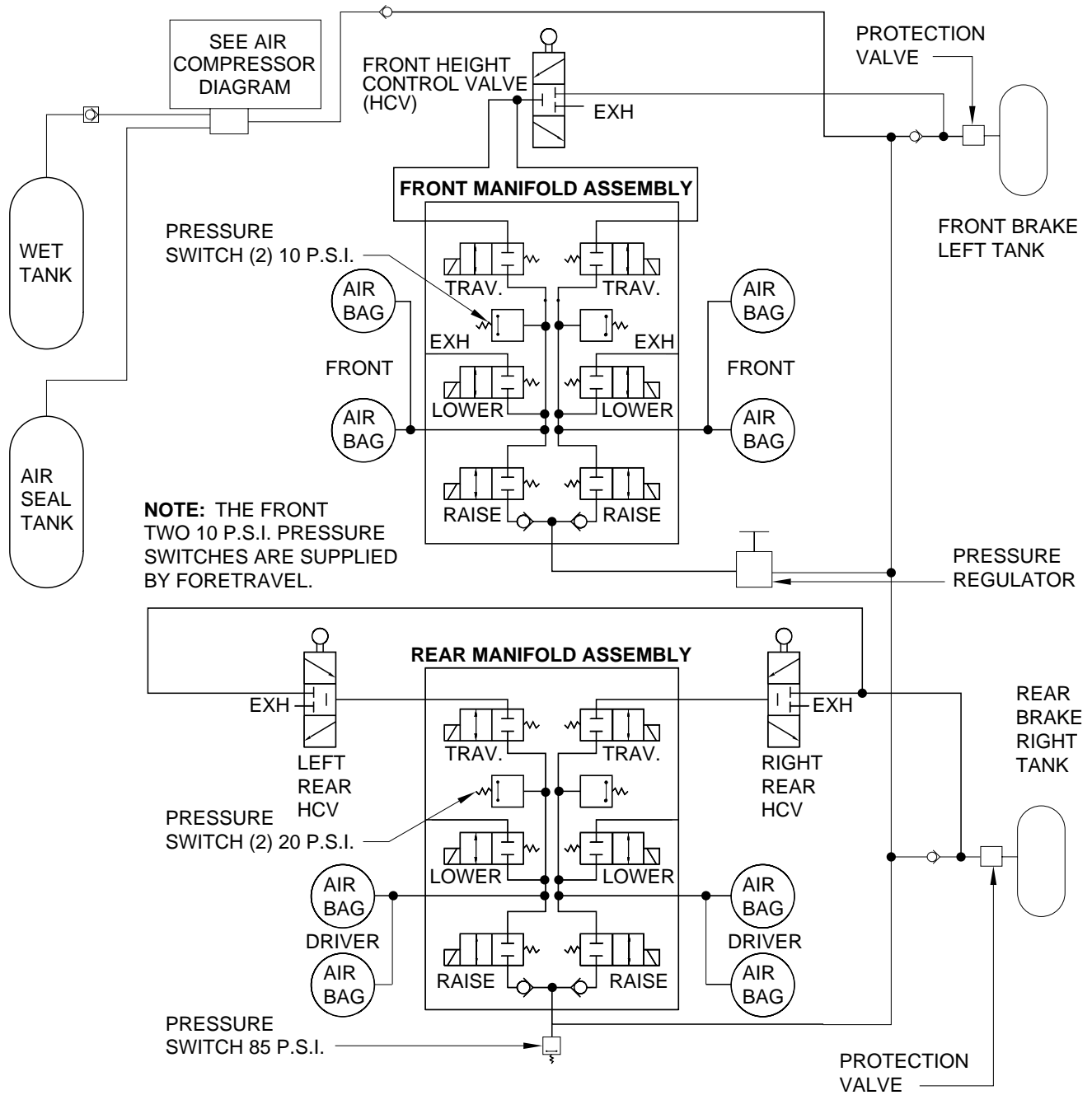



# REAR AIR SOLENOID MANIFOLD CONNECTIONS

## 6 VALVE WITH THREE PRESSURE SWITCHES

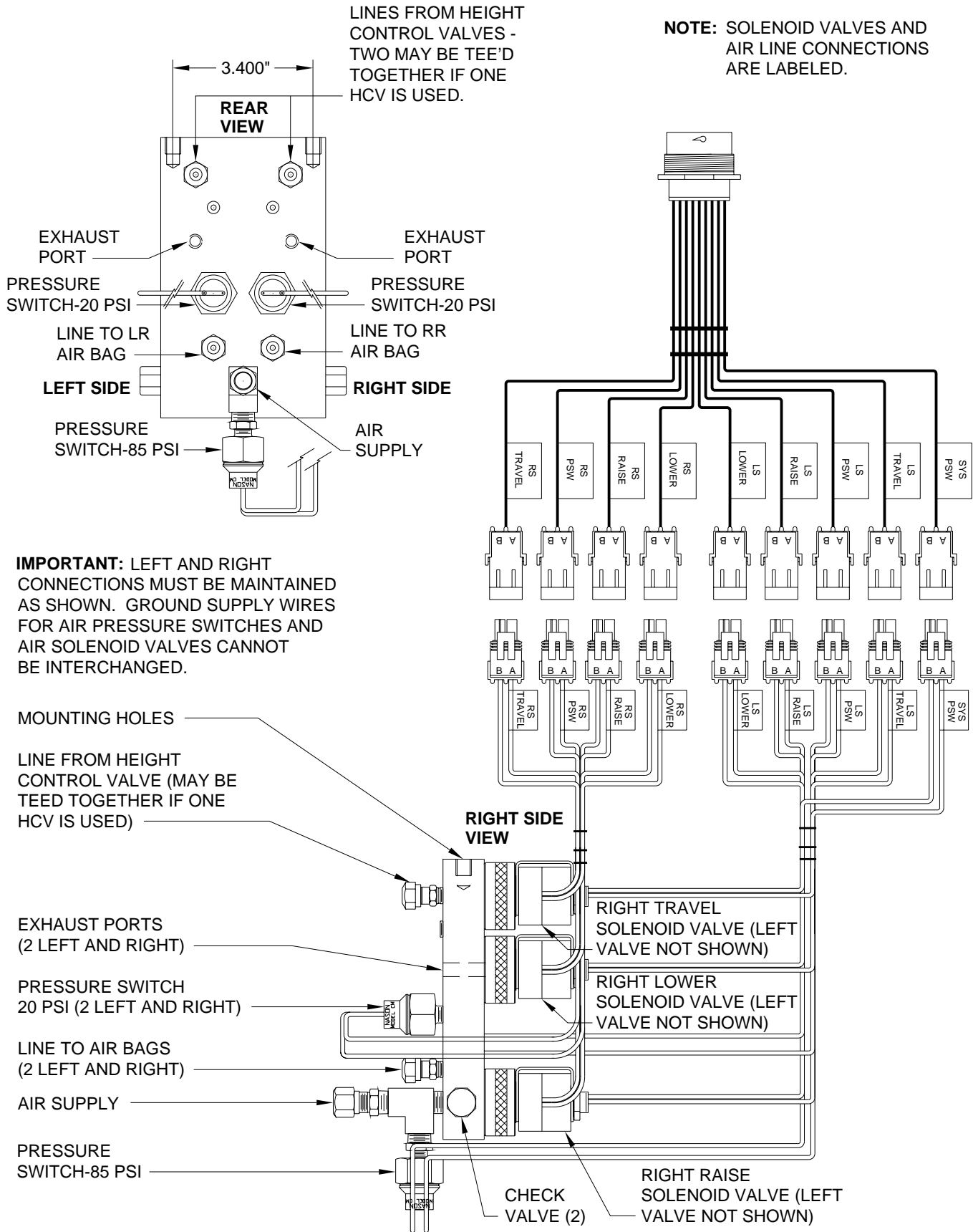

**IMPORTANT:** LEFT AND RIGHT CONNECTIONS MUST BE MAINTAINED AS SHOWN. GROUND SUPPLY WIRES FOR AIR PRESSURE SWITCHES AND AIR SOLENOID VALVES CANNOT BE INTERCHANGED.

MOUNTING HOLES

LINE FROM HEIGHT CONTROL VALVE (MAY BE TEE'D TOGETHER IF ONE HCV IS USED)

EXHAUST PORTS (2 LEFT AND RIGHT)

PRESSURE SWITCH 20 PSI (2 LEFT AND RIGHT)

LINE TO AIR BAGS (2 LEFT AND RIGHT)

AIR SUPPLY

PRESSURE SWITCH-85 PSI

# AIR CONNECTION DIAGRAM AUXILIARY COMPRESSOR

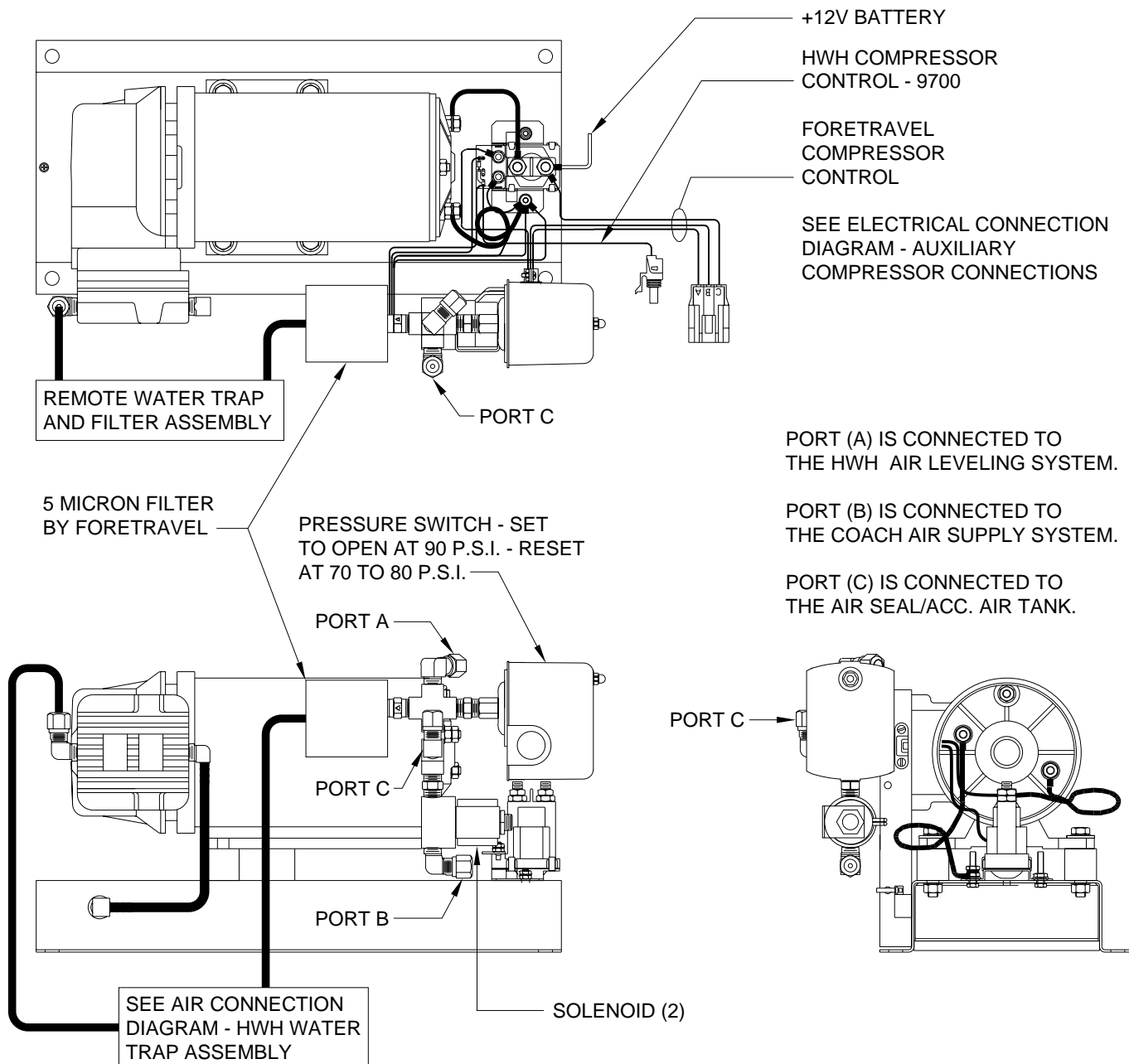

SOLENOID (2) OPENS WHEN THE FORETRAVEL DASH SWITCH IS ON. THE AIR COMPRESSOR RUNS IF THE PRESSURE SWITCH HAS RESET (COACH AIR BELOW 70 - 80 P.S.I.). THIS MAINTAINS COACH AIR SUPPLY AT APPROXIMATELY 90 P.S.I. IF THE VEHICLE IS EQUIPPED WITH AN AIR AWNING THE COACH AIR SUPPLY WILL BE MAINTAINED AT 110 P.S.I.

THE AIR COMPRESSOR RUNS WHENEVER THE PRESSURE SWITCH RESETS (AIR SEAL/ACC. TANK BELOW 70 - 80 P.S.I.). THIS MAINTAINS THE AIR SEAL/ACC. TANK AT APPROXIMATELY 90 P.S.I.

# AIR LINE CONNECTION DIAGRAM

## HWH WATER TRAP ASSEMBLY

**THE WATER TRAP ASSEMBLY IS MOUNTED REMOTE FROM THE AUXILIARY COMPRESSOR ASSEMBLY**

AIR SUPPLY FROM  
AUXILIARY  
COMPRESSOR

**TOP VIEW**

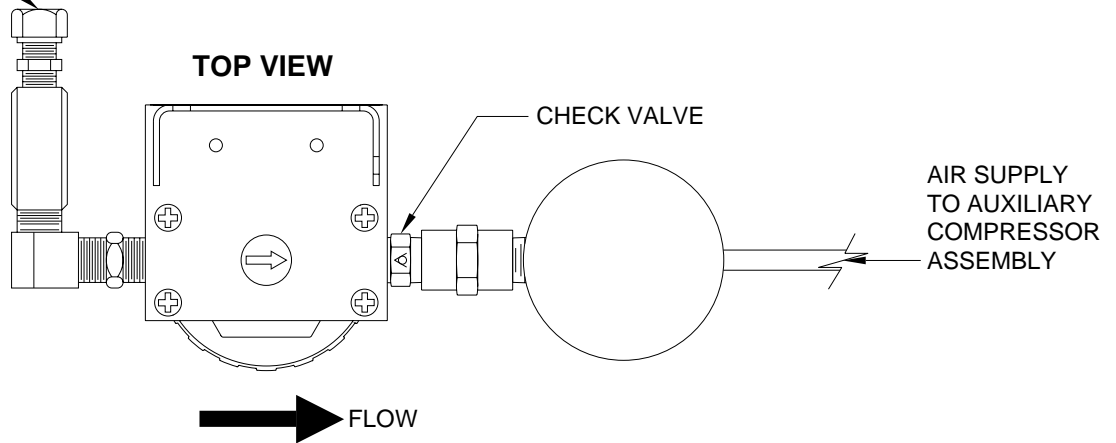

**SIDE VIEW**

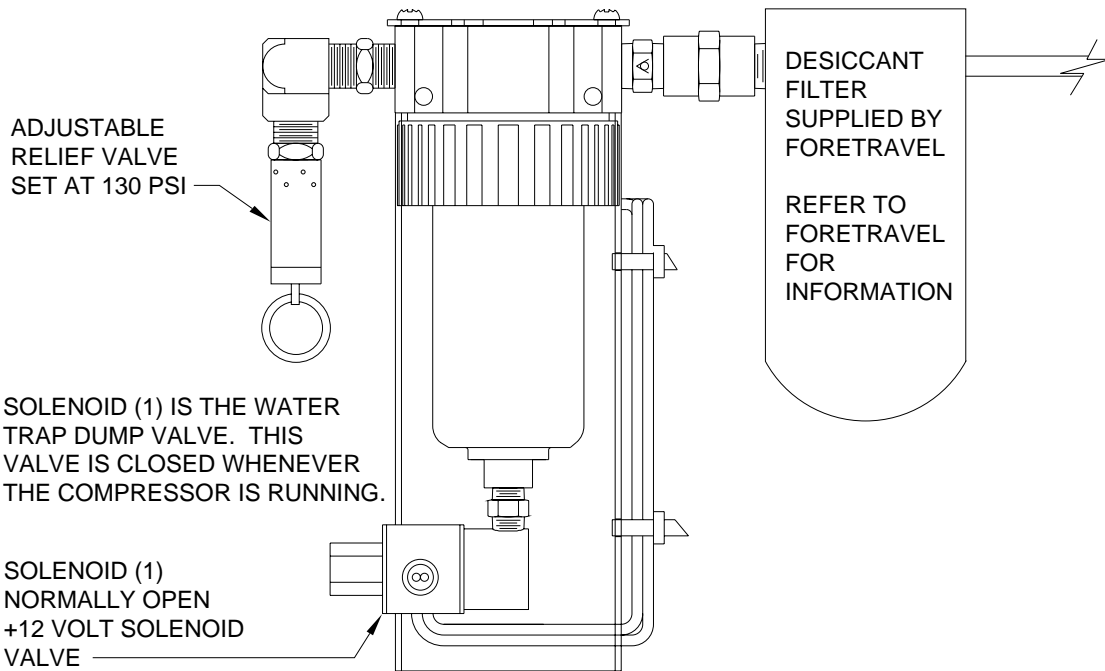

SEE ELECTRICAL CONNECTION  
DIAGRAM - AUXILIARY COMPRESSOR  
CONNECTIONS FOR ELECTRICAL  
CONNECTION INFORMATION.

# AIR CONNECTION DIAGRAM AIR COMPRESSOR SCHEMATIC

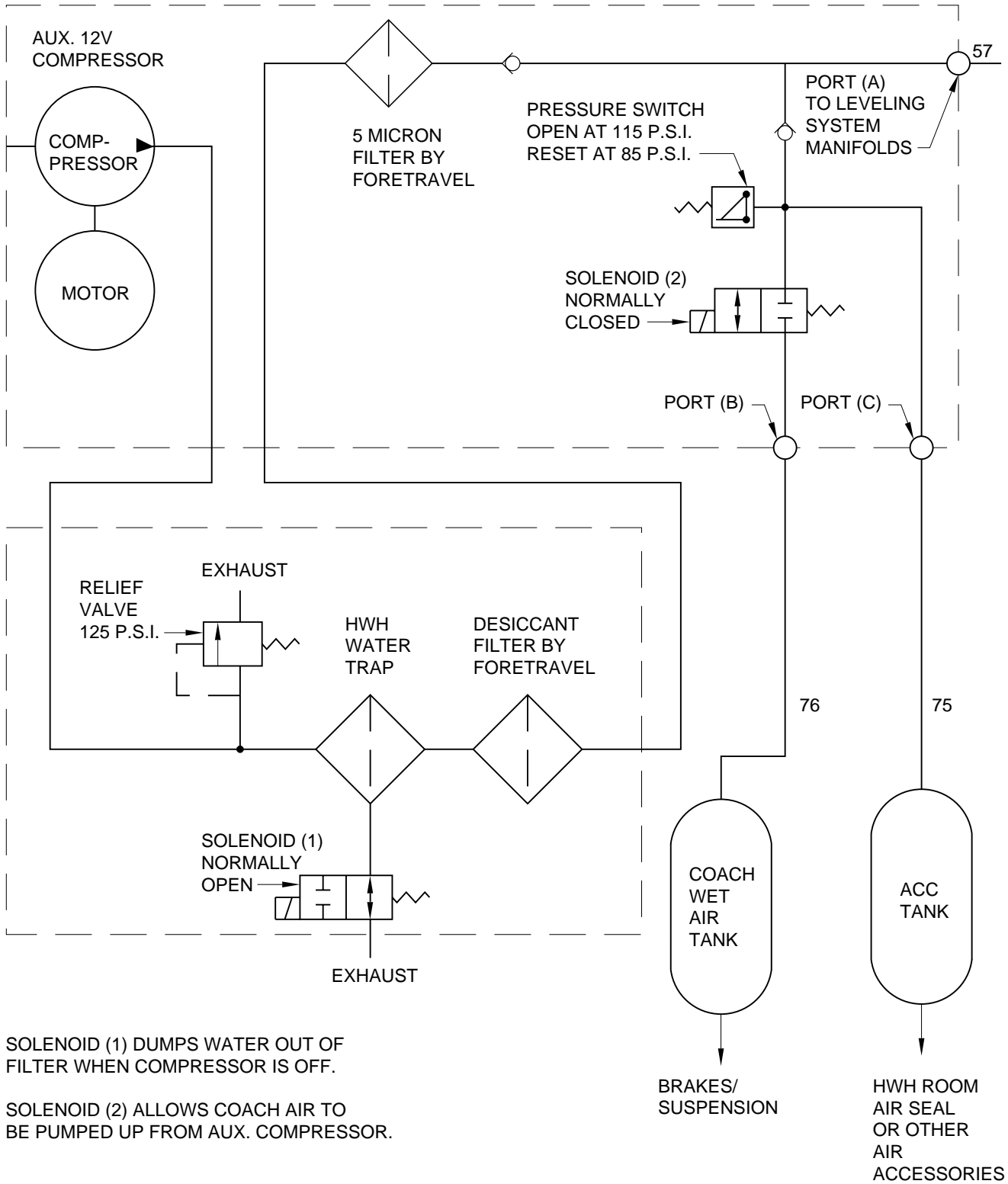

# AIR SEAL CONNECTION DIAGRAM

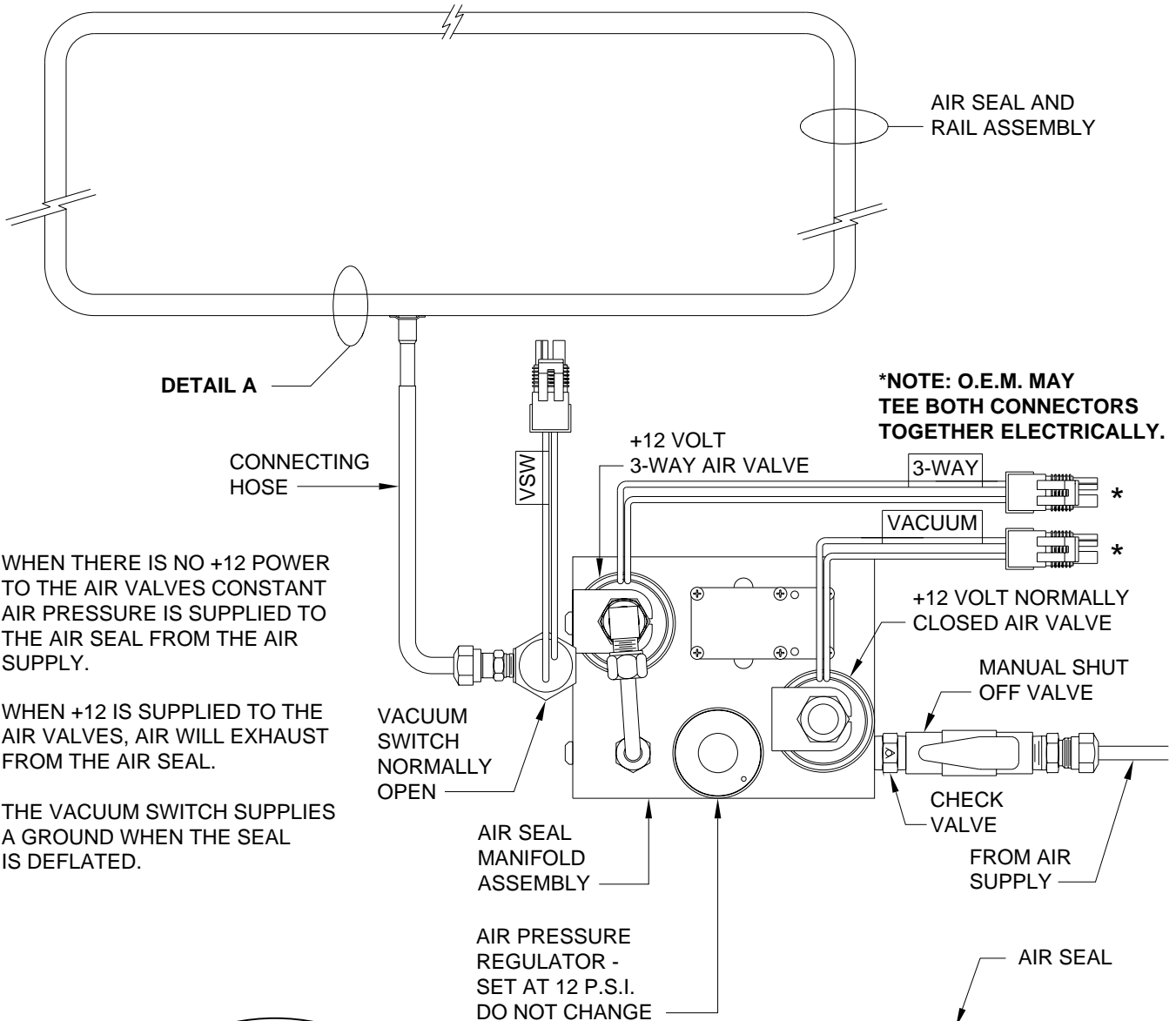

**\*NOTE: O.E.M. MAY  
TEE BOTH CONNECTORS  
TOGETHER ELECTRICALLY.**

WHEN THERE IS NO +12 POWER TO THE AIR VALVES CONSTANT AIR PRESSURE IS SUPPLIED TO THE AIR SEAL FROM THE AIR SUPPLY.

WHEN +12 IS SUPPLIED TO THE AIR VALVES, AIR WILL EXHAUST FROM THE AIR SEAL.

THE VACUUM SWITCH SUPPLIES A GROUND WHEN THE SEAL IS DEFLATED.



**DETAIL A**

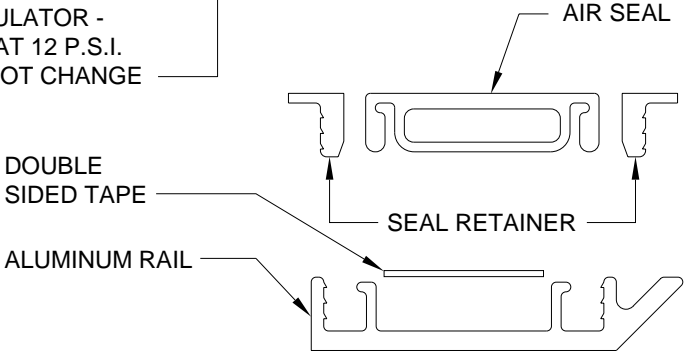

**EXPLODED VIEW**



# ELECTRICAL CONNECTION DIAGRAM AUXILIARY COMPRESSOR CONNECTIONS

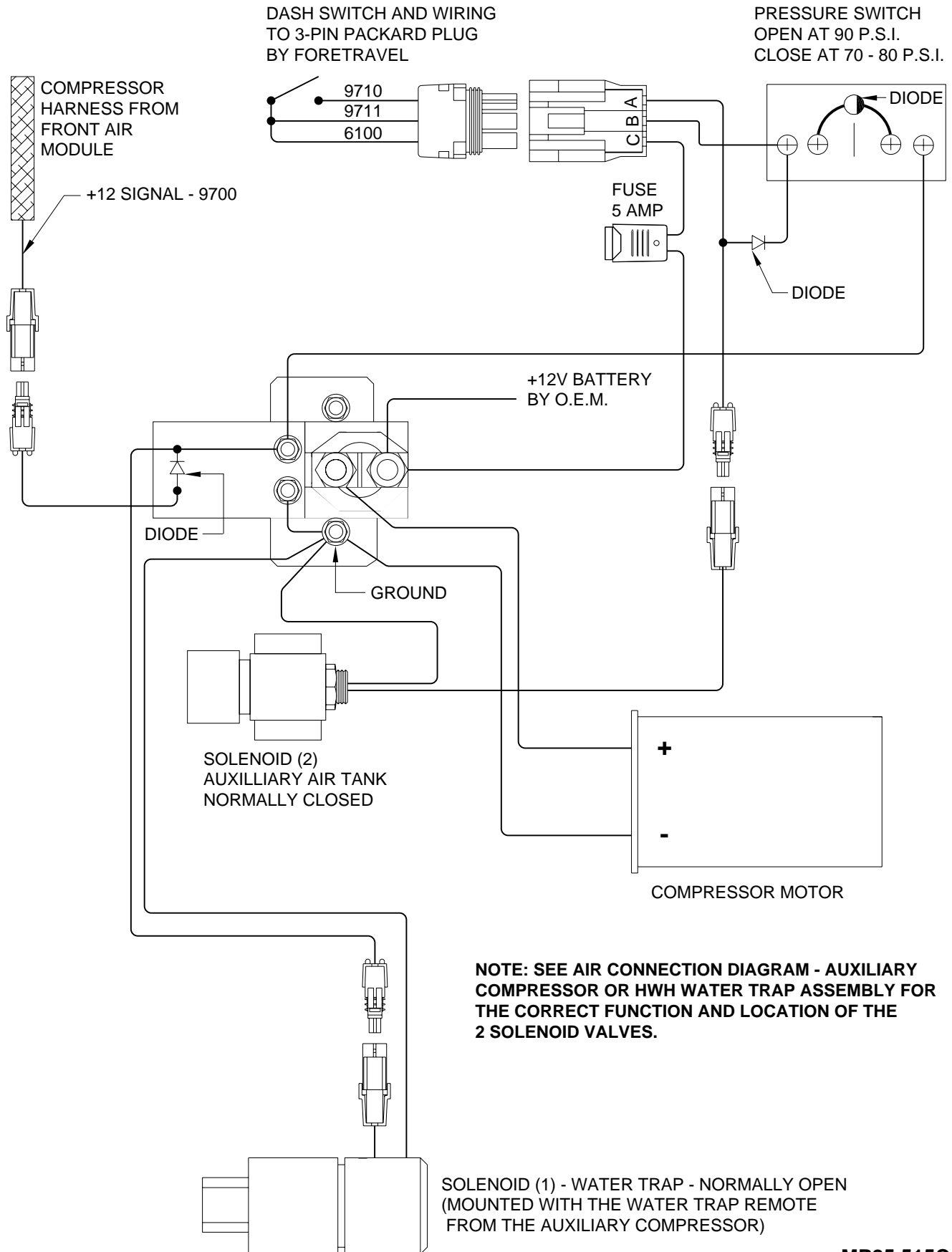

**NOTE: SEE AIR CONNECTION DIAGRAM - AUXILIARY COMPRESSOR OR HWH WATER TRAP ASSEMBLY FOR THE CORRECT FUNCTION AND LOCATION OF THE 2 SOLENOID VALVES.**

# BREATHER CAP - DIPSTICK - 1/4" NUT DRIVER

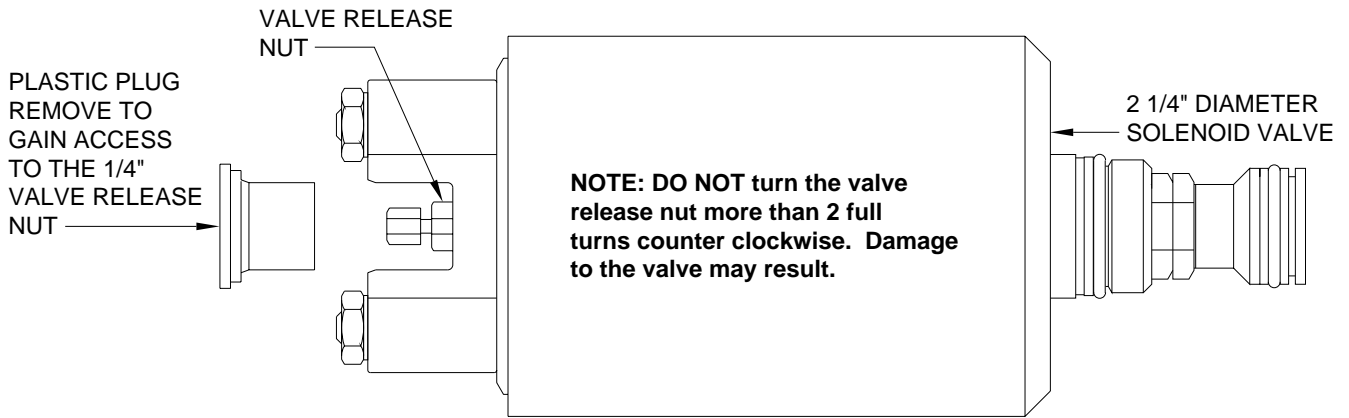
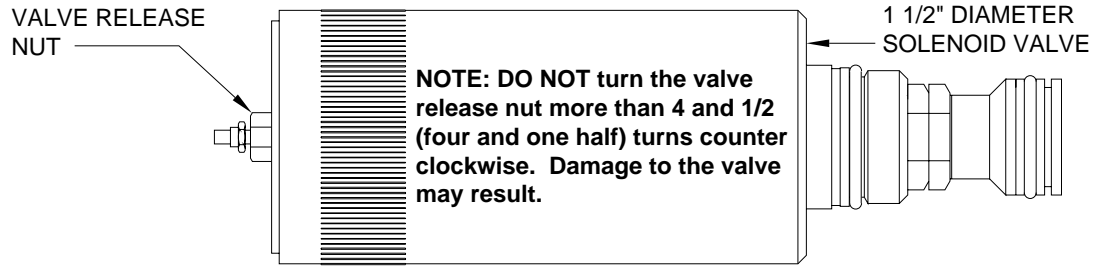

**NOTE: THE BREATHER CAP IS LOCATED ON THE TOP SIDE OF THE POWER UNIT RESERVOIR.**

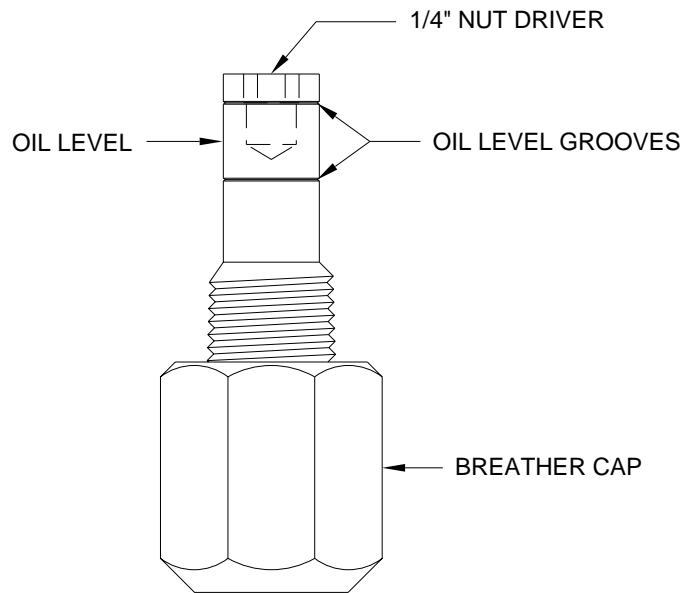

**IMPORTANT: PRIOR TO REMOVING THE BREATHER CAP, EITHER TO CHECK THE OIL LEVEL OR TO USE THE 1/4" NUT DRIVER, CLEAN ANY DEBRIS FROM THE TOP OF THE RESERVOIR. BEFORE RETURNING THE BREATHER CAP TO THE RESERVOIR, REMOVE ANY PAINT CHIPS OR OTHER DEBRIS FROM THE DIPSTICK INCLUDING DEBRIS INSIDE THE 1/4" NUT DRIVER.**