

# ELECTRONICS & HWH – 19APR11

## 1. PREFACE

This section deals with electronic equipment and components. We will discuss common electronic components and components that are specific to HWH. The discussion will include identification of the components, how these components function and diagnostic information needed for testing. In the component section we will discuss most of the different electrical connectors that are used by HWH. This will help you identify the connector along with an explanation of how to assemble and remove wires and/ or pins from the connectors. We will also discuss the correct tools needed to work on these connectors. There is also a section on test and repair equipment. This section describes some basic equipment needed to diagnose and repair HWH systems. The discussion includes choosing equipment and the function and correct use of this equipment.

## 2. ELECTRICAL COMPONENTS.

**2-1 MANUAL CONTROL SWITCHES.** Manual switches come in many styles and many different contact actions. We use toggle switches, rocker switches, push button switches and key switches. The terminology used to describe the contact actions is important to understand. A **momentary switch** is a switch that will return to its original position when released. You have to push and hold the switch to keep it activated. A **maintained switch** is a switch that will remain in the position it is pushed to. This type of switch has to be pushed to return it to its original position. A **normally open switch (NO)** has contacts that are open in the off position. A **normally closed switch (NC)** has contacts that are closed in the off position. A **single pole switch (SP)** controls only one circuit at a time. A **double pole switch (DP)** controls two circuits at a time. The key switch on our room panels can control three circuits at a time (**3P**). A **single throw switch (ST)** only has two positions, off or on. The switch can be normally open or normally closed. A **double throw switch (DT)** will have several positions. The switch could be a two position switch that is on in both positions or it may be a switch that has three positions, on off on.

We use one hybrid switch on the 100 and 110 series (4 lever systems) leveling systems with air dump. That switch is a double pole switch with single throw contacts but it works as an off, on (maintained) and on (momentary) switch. You will see labeling for standard switches that looks like this:

- SPST-single pole single throw
- SPDT-single pole double throw
- DPST-double pole single throw
- DPDT-double pole double throw

The symbols that HWH uses in diagrams and schematics for different switches look like this:

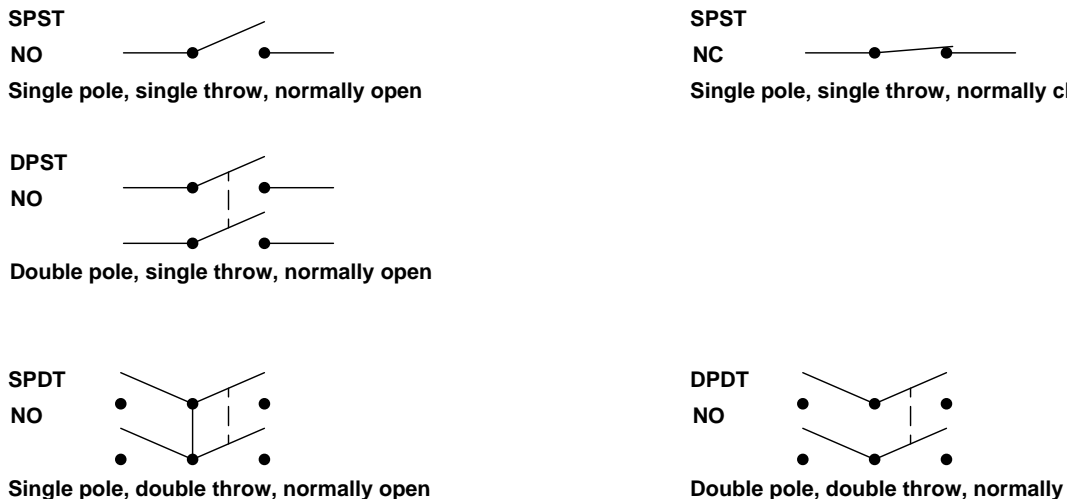

Fig. 1

Another important thing to note about switches is their current capacity. Like wires, switches can conduct only so much current without overheating or burning out. The current capability of the switch along with the maximum voltage the switch can be used with is usually indicated on the body of the switch. It is important that these capacities are not exceeded. The contacts of the switch will probably be ruined if its capacity is exceeded. This is why we use relays that can supply large amounts of current to different loads instead of wiring the load directly to the switch. Most of our manual switches are rated for 5 to 10 amps, some up to 15 or 20 amps. It is important that the correct switches are used to maintain correct operation of our systems.

Switches also have different types of terminals. The terminals can be soldered, such as with a board mounted switch or they can be used with fast-on connectors (push on) or ring terminals (screw on). Terminals are usually numbered. The numbers are used to make assembly and repair diagrams to make sure the switches are wired and assembled properly.

**2-1.1 Manual switch diagnostics** is very simple once the switch action is known. Answering a couple of questions will usually diagnose switch problems. Will the switch stay where it is supposed to if it is a maintain type switch? Will the switch release or does it seem to stick if it is a momentary switch? Do the contacts open when they are supposed to? (There is no continuity between the proper terminals of the switch.) Do the contacts close when they are supposed to? (There is continuity between the proper terminals of the switch.) ***Or simply, is there power through the switch when there is suppose to be power and is there no power through the switch when there is not suppose to be power?***

**2-2 ELECTRIC COILS** are not an individual component in our systems but coils are used in relays and solenoid valves and it is important to understand how coils function. A coil is nothing more than a long wire wrapped around a spool, like a spool of thread. When power and ground are applied to the opposite ends of the wire, it creates a magnetic field that makes the core move. This opens or closes the electrical contacts of a relay or opens or closes the seat of a valve.

All coils have a resistance value which can be checked but there is an easier way to check components that have a coil. Components with coils are rated for a particular voltage, 12 or 24 in our case. These components also have a minimum voltage at which they will operate or pull in and when they will drop out. An example of this is our solenoid valves. The valve must pull in at no more than 8.5 volts and stay energized (not drop out) until the voltage drops to 2 volts or less. If you check components with a coil in this manner, the resistance value of the coil is not needed. If a solenoid valve will not pull in until 9 volts, the valve is bad no matter what resistance the coil is producing. If a valve drops out at 4.4 volts, the valve is bad. Again the resistance does not matter. Sometimes the easiest test to do on a coil is just check continuity between the two sides of the coil. If there is no continuity, the coil is bad.

Components with coils can also be affected by the length of time they are on. The wire used to make coils is insulated. This insulation can deteriorate under an excessive heat situation. The longer a coil is on, the more heat can be generated. This depends on the design of the coil. If one of our small valves is on over 20 minutes, the coil can start to deteriorate and damage the valve. The relays we use for our master relay or the valves we use for our air leveling systems can be on for hours without damage. If the coil wire deteriorates enough, this can create a short or an open spot in the coil. A coil with a short will usually blow the fuse that protects that circuit. If there is no fuse or the fuse does not blow, the wires or other components in the circuit can be damaged. If there is an open spot in the coil, the component simply will not work. The coil will show no continuity between the two ends of the coil.

Finally, when the coil is turned off, it will discharge a large amount of voltage. This discharge can cause damage to the switch. By placing a diode in line with the coil, this will allow the voltage to dissipate through the coil instead of through the switch contacts. This is important because a component with a diode installed in the component must maintain the proper polarity when it is wired into the circuit. This is called a “back emf diode”. If the component is wired in reverse, this will ruin the diode because a direct short is created in the component. This will create a short in the circuit and blow a fuse or damage wiring or other components. Sometimes the diode will be completely destroyed. This will allow the component to work but will now have no protection against the voltage spike when the coil is turned off. Other components can now be damaged. For most components, we have protection built into the control circuit. Our large valves used to have the diode built into the valve. Large replacement valves still have the diode for use in older systems, but this same replacement valve is used for repairs in new systems also. It is just a good rule of thumb to not change the polarity of the wiring in a system. You never know when you may be causing an issue.

We will show you examples of coils with and without diodes when we discuss other components such as relays (next component we discuss) or solenoid valves.

**2-3 RELAYS.** Relays are electrically controlled switches. (They are sometimes referred to as solenoids but if it is used as a switch, it is a relay.) Pictured are several relays presently used by HWH. In the past, HWH has used different styles and brands of relays. Some of the older relays are still available but if not, the present relays can be adapted to any system produced by HWH.

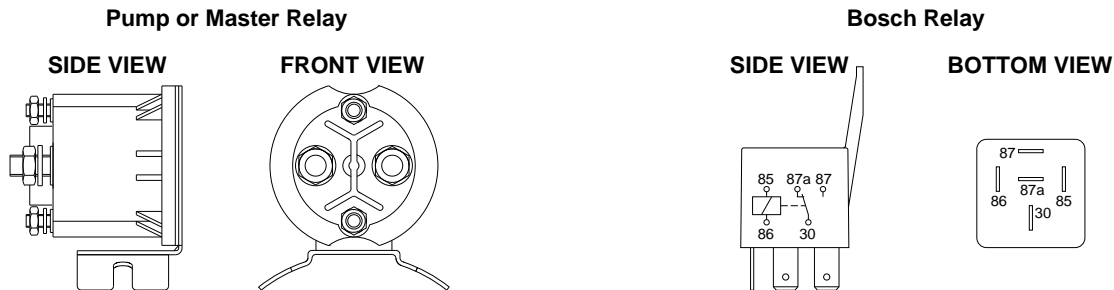

**Fig. 2**

A relay consists of an electrical coil and a set of contacts. The coil is used to produce a magnetic field that moves the contacts. The coil of a relay is designed to work with a specific amount of voltage. If an incorrect amount of voltage is used to operate a relay, the relay will probably malfunction. The coil of the relay will burn out if the voltage is too high or will not function if the voltage is too low.

The contacts of a relay have limitations. The contacts will have a maximum amount of voltage and current they can withstand without damaging the contacts. All of the relays we use are non-directional and the contacts can be used to switch + voltage or ground. Either terminal for the relay contacts could be the supply side or the output side. The relay coils are also non-directional. There is no diode installed on the coil of the relays we use. Either terminal for the relay coil could be the + voltage or the ground for the coil. A relay can have normally open contacts, normally closed contacts or both. Some relays can be wired to operate as normally open or normally closed. A relay of this type could be used to control two different circuits, one normally closed circuit and one normally open circuit.

Relays are also designed according to the frequency the contacts are operated. There are **continuous duty relays**. These relays can be on for long periods of time without causing damage to the relay, but should not be turned off and on rapidly in a short period of time. There are **intermittent duty relays**. These relays are designed to be cycled off and on while being used. ***It is important that the correct relay is used and although they look similar, one relay maybe continuous duty and the other intermittent duty. Our relays should not be confused with the Ford starter relay or other relays of that type.***

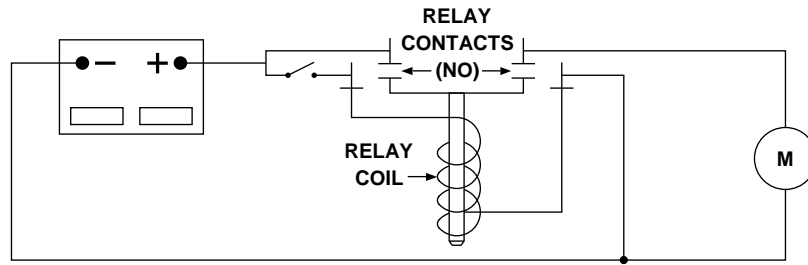

Fig. 3

We use relays for many different purposes. We use them to switch large amounts of current that a manual switch or a computer processor will not handle. They are used to send information to computer processors from limit switches or warning switches. They can also be used as a safety switch to interrupt a process that is reaching a critical condition that could create a system or component failure. Many of the relays we use are pc board mounted and are not field serviceable. The main relays we use that are serviceable are on the hydraulic pump motors and on our air compressor assemblies. There are two different types of relays used on the hydraulic pump motors, a continuous duty and an intermittent duty relay. The continuous duty relay is only used with automatic, computerized systems. This relay is called the *master* relay. Systems that do not use a hydraulic pump may have a master relay. It may be mounted in a control box or remote from the control box. System diagrams or schematics will supply this information. The intermittent duty relay is called the *pump* relay and is used with any system that has a hydraulic pump motor. The relay used on air compressor assemblies is a continuous duty relay. All three of these relays have normally open contacts. The coil of all pump and air compressor relays is controlled with a + signal except for the pump relay on 400 series leveling systems and 200 series Joystick leveling systems. A switched ground controls these relays. Safety and other relays may be controlled by either a + voltage or ground signal. You should always check system diagrams and/or schematics to determine the control signal for a relay.

We use a small Bosch relay as a safety switch with all four cylinder and other pressure sensitive room extension mechanisms. This relay is normally mounted on the pump motor. The Bosch relay can be wired as a normally open or normally closed relay. Check specific system wiring diagrams for use and orientation of the relay contacts.

**2-3.1 Relay diagnostics.** Before doing the actual diagnostics, it is important to know a few things about the relay and the circuit it is in. Are you switching + voltage or ground? Is the relay a normally open or normally closed relay? Is the relay coil controlled with a switched + voltage or a ground?

Most of the relays we use draw less than 1 or 2 amps so operating a relay does not create much of a load, a test light will usually do most of the diagnostics needed or at least give you the basic answers to the tests for relay diagnostics. When helping someone diagnose a relay problem, one statement I frequently get is; “*my test light will come on when I touch either of the coil terminals*”. You need to remember that a coil is just one long wire wrapped around a metal rod. **If there is + voltage on both relay coil terminals there is no ground for the coil. If there is a ground on both relay coil terminals, there is no + voltage to the coil of the relay.**

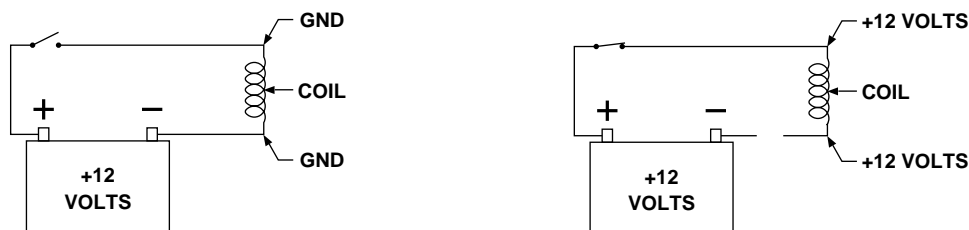

Fig. 4

Most of our relays should pull in at a minimum of seven to eight volts and stay on with less voltage. If a relay is the relay contacts to stick or burn out. Remember, the ground for the relay could be the problem as easily as the + voltage could be the problem. Whether it is a “voltage” problem or a grounding problem, low voltage will ruin a relay quicker than most other issues. Also a very common problem with the relays on the pump is loose connections or corrosion. An easy way to test a connection is with a voltmeter. The relays must be on and the pump motor should be running. (This method can be used to test any connection as long as the load for that connection is on.) Put one lead of the meter on the relay post and the other lead on the wire terminal. The meter should show zero voltage. Any voltage reading would indicate an unwanted resistance at the connection. Finally, there should be zero voltage drop between the input and output posts of a relay.

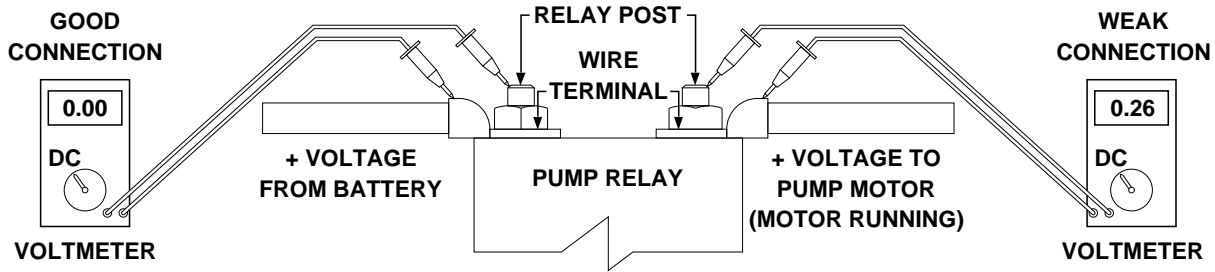

Fig. 5

Connections can also be tested by comparing the voltage at the post to the voltage at the wire terminal. The voltage should be the same when the exact same ground point is used to check the voltage. The main ground point for the system should be used when testing connections this way. The load needs to be running for this test procedure also.

**Normally open (NO) relay diagnostics.** If the relay will not turn on (close the contacts), the following tests should be made. These tests are made with the relay on. This is where a test light will give you the basic answers you are looking for. *It is always a good idea to check your test light with a known good voltage and ground source to verify that your test light is working. I speak from experience.*

1. Is there + voltage (or ground) to the supply (or input) side of the relay?
2. Is there + voltage to one of the coil terminals of the relay?
3. Is there ground to the other coil terminal of the relay?
4. If 1, 2, and 3 are yes, is there + voltage (or ground) to the output (switched) side of the relay?

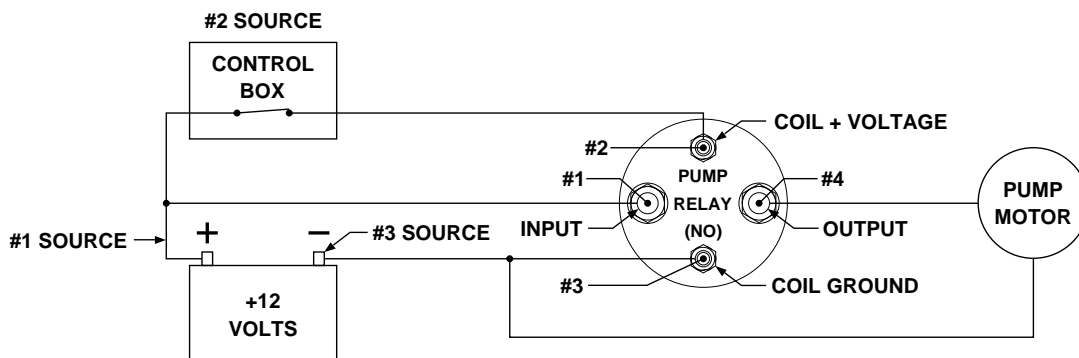

Fig. 6

As always, it is a matter of using the process of elimination. If the answer to #1 is no, there is no + voltage or ground to the supply side of the relay, check that source. If the answer to #1 is yes, check #2 then #3. If the answer to #2 or #3 is no, check their source. If the answer to #2 and #3 is yes, go to #4. If the answer to #4 is yes, the relay is good. If the answer is no, there is no voltage (or ground) on the output side of the relay, the relay is bad.

Diagnosing a normally open relay that is on (contacts closed) at all times is easy to diagnose. All that needs to be done is to remove the control wire or check the control wire for + voltage or ground, whichever is used to control the relay coil. If the control voltage or ground is not present or the control wire is removed and the relay stays on, the relay is bad. It is important to note that sometimes the relay contacts will open if the relay is tapped. It may not take much of a tap to cause the contacts to open. If the relay suddenly starts to function properly after being tapped, it was probably stuck contacts in which case the relay should be replaced.

**Normally closed (NC) relay diagnostics.** Diagnosing a normally closed relay is much the same as diagnosing the normally open relay. You just are looking for some different answers as you perform the tests. When diagnosing a relay that will not turn on, (open the contacts) you start by turning the relay on to perform the tests.

1. Is there + voltage (or ground) to the supply (input) side of the relay?
2. Is there + voltage to one of the coil terminals of the relay?
3. Is there ground to the other coil terminal of the relay?
4. Is there + voltage to the output side of the relay?

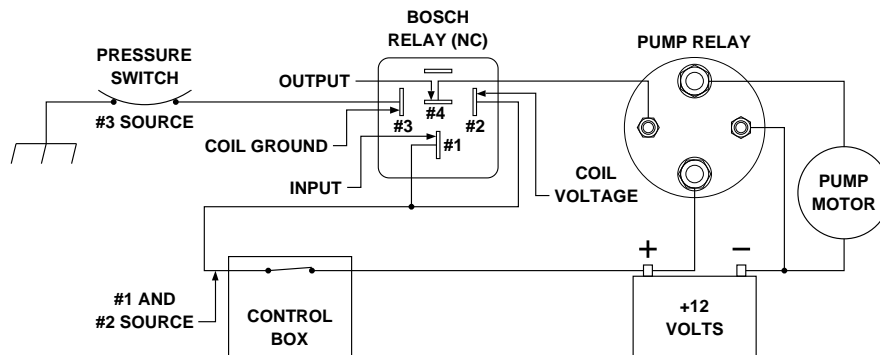

Fig. 7

Check #1. If the answer to #1 is no, there is no + voltage (or ground) to the supply side of the relay, check its source. If the answer to #1 is yes, check #2 then #3. If the answer to either is no, check the source for that terminal. If #2 and #3 are answered yes, check #4. (Here is the difference between a normally open and normally closed relay.) If the answer to #4 is yes, the relay is bad. If the answer is no, the relay is good.

As with a normally open relay, if the contacts of a normally closed relay will not close, remove the control voltage or ground from the relay. If the contacts remain open, the relay is bad.

When diagnosing any relay, it is important to remember that the wire connections to the relay may be the issue and not the relay. Many relays are changed because of a miss-diagnosed problem. A weak connection can seem to be a bad relay. When the relay is replaced, the problem is fixed, not because the relay is bad, but because the connections are fixed when the relay is replaced. ***When diagnosing a relay using the diagnostic procedure discussed above, put the probes of the test light or meter on the relay posts, not the wire terminals.*** If connections are weak, that will show up when testing.

**2-4 FUSES** are an important control device in any electrical system. Fuses are used to protect wiring or printed circuit boards from damage or fire. Damage or fire is caused by over heating due to excessive current draw because of a faulty component, circuit overload or a short. A fuse, very simply, creates a break in the circuit when its current rating is exceeded. We have used many different types of fuses over the years. We have used automatic circuit breakers, automotive glass fuses, large blade fuses, standard size automotive blade fuses, the newer mini-blade fuses, buss type fuses and poly fuses. The circuit breakers and large blade fuses are no longer used. The poly fuses are only used on pc boards in control boxes or panels. **Glass, buss and blade fuses** have a conductor that burns and creates a break in the circuit when the current rating of the fuse is exceeded. **Circuit breakers** have contacts that will open when the current rating of the breaker is exceeded.

Circuit breakers can be reset automatically or manually. The use of automatic circuit breakers is not recommended. **Poly fuses** are unique in the fact they don't have to be replaced or reset after "tripping". As the current rating of the poly fuse is exceeded, the heat will cause the material of the poly fuse to totally resist the flow of current. The poly fuse will remain "open" until current is removed from the supply side of the fuse or the overload or short is removed from the load side of the fuse. Fuse size is very important. Something that is quite often overlooked is the traces on pc boards. Fuses are also sized to protect these traces. **Correct fuse size must always be maintained.** When too large a fuse is used, the wiring or traces are put in jeopardy. Traces can easily be burnt when fuses are oversized and this usually is an expensive repair. Wiring can overheat which can cause a fire. This is an even more expensive repair. Too small of a fuse will not usually cause damage but will certainly affect the performance of the system by causing a break in the circuit even though the circuit is operating well within its rated capacities. The main thing to remember about fuses when diagnosing fuse issues is; **only an overload or short on the load side of a fuse will cause a fuse to open or trip. No issue on the voltage/current supply side of the fuse can cause a fuse to open or trip.**

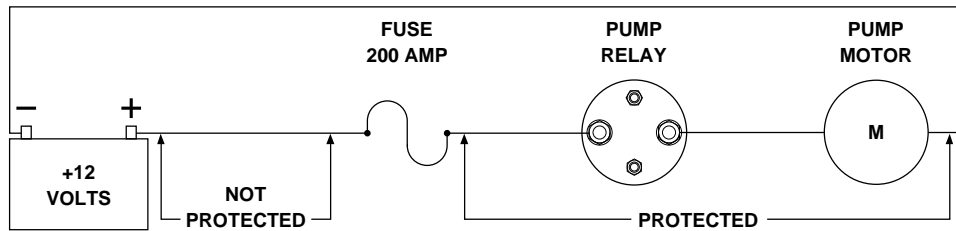

Fig. 8

**2-5 DIODES** are electronic devices used to control the direction current can flow. A diode will only allow current to pass through in one direction. The directions are referred to as forward and reverse bias. A diode installed into a circuit with a forward bias will allow the current to flow through. A diode installed with a reverse bias will block the flow of current. There are different types of diodes including LEDs which are "light emitting diodes". We use many diodes and LEDs in our systems, but most of them are mounted on pc boards or installed in a component such as the large solenoid valves and are not serviceable in the field. It is not even important to be able to diagnose diode issues when they are part of component. But sometimes when necessary, a diode may be used in a harness. When there is a diode in a harness, the harness will have a "DIODE" label at the point where the diode is installed. One way to check a diode with a meter is to set the meter to "DIODE CHECK". When checked in the forward bias, the meter should read approximately .5 volts. When checked in the reverse bias, the meter should read OL or open.

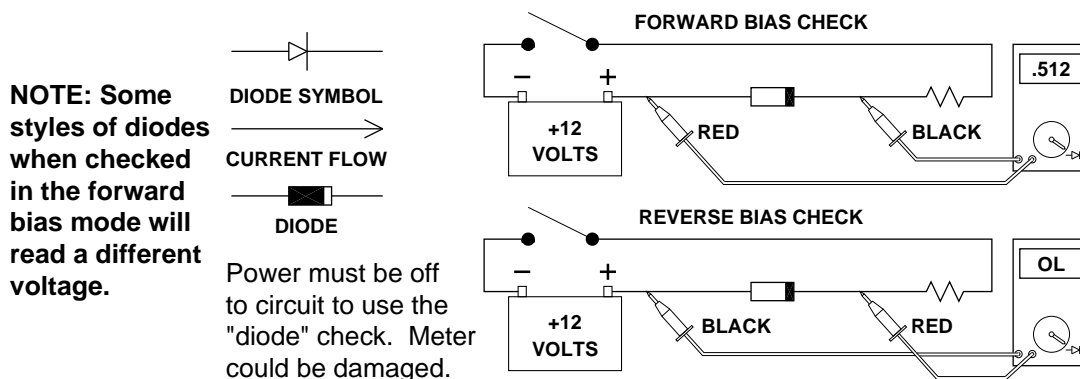

Fig. 9

**If the reading in both directions is "OL", the diode is open.**

**If the reading in both directions is 0.00, the diode is shorted.**

**If there is a diode in a harness wire, a continuity check of that wire cannot be performed.**

**2-6 TRANSISTORS** are electronic relays or switches. They are used to control the flow of current in a circuit. It will either allow the current to flow or stop the flow of current. There are three parts to a transistor, the base the emitter and the collector. There are two types of transistors but we are not going to discuss the construction or do an in-depth study of the theory of how the transistor works. Except for an old style solenoid valve, transistors are used exclusively at the board level of our components. I can think of no time (at the present) that you would have to do diagnostics that directly involve troubleshooting a transistor. It is necessary to understand what a transistor is and the basics of what it does when it becomes necessary to read a schematic.

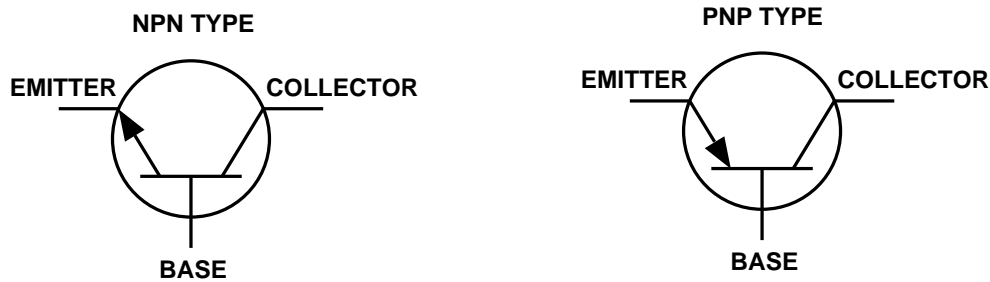

**Fig. 10**

In comparison to a relay, the base of a transistor (along with the emitter) is the coil and the emitter and collector are the contacts. The two types of transistors are the PNP and the NPN. The PNP transistor uses a ground to switch the base and the NPN uses a positive voltage to switch the base. When the base sees the switching signal, current can then flow through the transistor between the emitter and collector. The transistor symbol shows which way the current flows, always in the direction of the arrow.

**2-7 CONTROL BOXES AND PANELS** are the heart of HWH electrical systems. They can be very simple like the 100/110 system panels or very complex like the 2000 series CAN systems. Most systems will have one control box or panel but systems like the Active Air system or the 2000 series systems can have several different control boxes. A 110 panel has one small pc board on it but a 680 control box may have as many as 8 different pc boards in it. These pc boards can be very simple or very complex. For example, the 110 pc board has 11 resistors, 5 diodes, 1 transistor and 10 LEDs. That's not very many components considering you need 1 resistor for each LED. And that pc board controls the whole system. I'm not going to even try to count the components on one of the more complicated pc boards. Let me know if you want to, I will send you a schematic.

It may seem like I am trying to overwhelm you with how complicated systems are but that is not my intention. I just want you to know the range of what we deal with here at HWH. ***The important thing to realize is that no matter how simple or complicated the control box or panel is, the diagnostics for each one is fairly simple if you understand how the system operates and how the components function.*** Many of the system components that the control boxes or panels work with are the same no matter what system you are working on. A solenoid valve is a solenoid valve, a warning switch is a warning switch, a relay is a relay and etc. ***All any box or panel does is receive information and send out control signals. REMEMBER, POWER IN, POWER OUT.***

All boxes and panels have connectors to link them to the system components such as the valves, relays, warning switches or pressure switches to name a few. Although some are more readily available than others, there are diagrams available for all boxes and panels that will label the inputs and outputs. This will tell you which connectors and which pins are connected to which system components. And once you understand how the different components function, you are almost home. ***This section of the school (2. ELECTRICAL COMPONENTS) is probably the most important section of the Electrical School.*** Maybe the most important thing to remember about control boxes and panels, especially the computerized systems, is to not let them intimidate you. Understand the system components and diagnosing control boxes and panels, for the most part, will be easy.



Maybe the most important things to consider when working on one of our systems with a control problem is: “**Which system is it?**” This can be more complicated than diagnosing the problem. All of our different systems have a series number but this number is not noted anywhere on control boxes, touch panels or light plates. As of December of 2010 the different series we have available or were available in the past are:

- 100/110 series-independent, lever controlled manual leveling system. **HYD ONLY**
- 200/210/225 series-joystick controlled bi-axis leveling system. **HYD ONLY**
- 300 series-touch panel controlled computerized leveling system. **AIR ONLY**
- 310 series-touch panel controlled manual bi-axis leveling system. **HYD ONLY**
- 305/325 series-short board, touch panel controlled manual bi-axis leveling system. **HYD ONLY**
- 325 series-long board, touch panel controlled manual bi-axis leveling system. **HYD ONLY**
- 400 series-paddle switch controlled computerized leveling system-independent or bi-axis. **HYD ONLY**
- 500 series-touch panel controlled computerized bi-axis leveling system with 14” control box. **AIR & HYD**
- 510 series-touch panel controlled computerized bi-axis leveling system. **HYD ONLY**
- 600 series-touch panel controlled computerized bi-axis leveling system with 14” control box. **AIR & HYD**
- 610 series-touch panel controlled computerized bi-axis leveling system. **HYD ONLY**
- 610 series-touch panel controlled central grounded computerized bi-axis leveling system. **HYD ONLY**
- 625 series-touch panel controlled computerized bi-axis leveling system. **HYD ONLY**
- 625s series-touch panel controlled single touch computerized bi-axis leveling system. **HYD ONLY**
- 680 series-touch panel controlled computerized bi-axis leveling system-rooms with hydraulic locks. **AIR & HYD**
- 700 series-touch panel controlled single touch computerized bi-axis leveling system. **AIR ONLY**
- 725 series-touch panel controlled single touch computerized bi-axis leveling system. **HYD ONLY**
- 2000 series-touch panel controlled CAN computerized bi-axis leveling or room control systems. **AIR & HYD**

Most of our leveling systems have a repair manual that is available on the HWH web site but you need to know which system you are working on to get the correct manual. **There are several different 610,325 and 625 repair manuals. It is very important to get the correct manual.** On the HWH website under “Customer Support & Technical Service” you will find “Leveling System Identification”. This section will give you visual and written information to help identify which system you are working on. Click on “Leveling System Identification” to link to this site. You can also use the “Parts Catalog” on the web site under “Customer Support & Technical Service”. There is a “HWH Control Box quick reference guide” in the parts catalog.

It is also very important to get the correct part number when ordering repair parts. There are different control boxes, touch panels or light plates in every series of leveling system. The 2000 series CAN system has over 150 different control box numbers. There are 8 different light plates for the 200/210/225 joystick leveling systems. The differences could be kick-down or straight-acting jacks, spring or air suspension, how many room extensions the vehicle has or a variety of other reasons. Different controls are used for motorized or towable units, rooms with locks or travel clamps or maybe the vehicle has air leveling with or without a tag axle. Whichever series the system is, it is important to make sure the correct controls are used. It is also important to note that sometimes we use a generic type control box that will replace several different control boxes. If the replacement box does not have the same number as the original, it could be a good idea to check and make sure it is the correct box.

*Just because two control boxes, touch panels or light plates looks the same, it doesn't mean they are the same.*

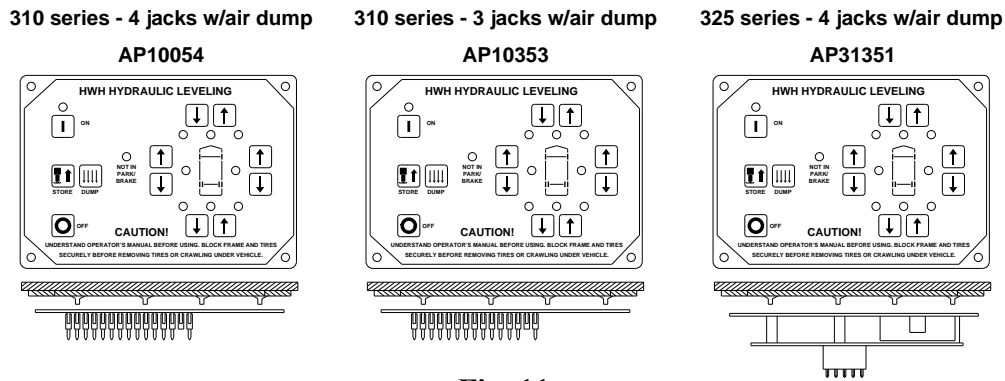

Fig. 11

You will notice that the touch panels in Fig. 11 all have the exact same lexan cover. There is no visible difference at all between the two 310 series panels. The only visible difference between any of the panels is that the 325 series panel has a different pc board and plug assembly. This difference would not be noticeable unless the panel was removed. Even then, you have to know what you are looking for. Control boxes are even worse. You could easily have 10, 20 or more boxes with no physical difference but due to programming differences in the computer chip, the boxes will have a different part number.

**2-7.1 Control box or panel diagnostics** as I said earlier, can be simple. I don't mean you will never encounter some system that makes you want to find a new profession. All of us, even our engineers have been there. But I can tell you from experience, 90% of the time we discover something simple that was missed because of inaccurate information or over-thinking the problem. A loose wire, corrosion, low battery voltage or something else that was overlooked. We have even seen a whole day wasted because nobody checked to see if the park brake was set.

The easiest way to diagnose an electrical problem if you don't understand the system or components is to use the correct repair manual. The HWH repair manuals are written in an order that follows the operation of the system. Anytime a problem is encountered while using the manual, the manual will explain what to check, where to check and what to check for.

The main thing to remember is the control boxes and panels function on the power in and power out theory. Making sure that the voltage and ground for the control panel or control box is within operating specs. is usually the first thing you will want to do. Once you establish you have good voltage and ground for the panel or box, you can diagnose the problem. The following are a couple of examples.

A solenoid valve will not open. Do you have power to the box? No power? If there is no power to the box the box cannot work. If there is power, then do you have power on the correct output pin for that valve? If there is power on the output pin for the valve, the problem is not the box. If there is no power on the output pin, check the appropriate fuse. If the fuse is blown, the problem is most likely not the box. If the fuse is good, the problem is most likely the box.

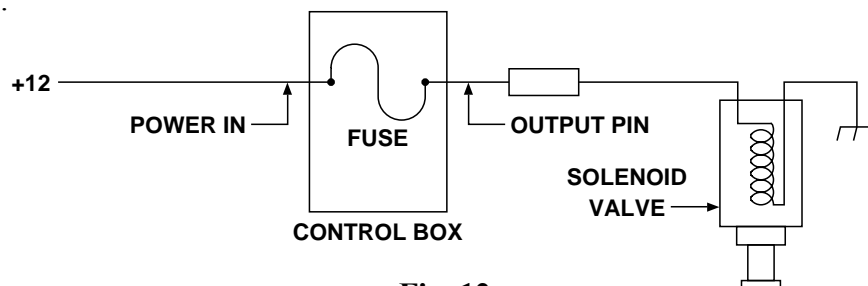

Fig. 12

One warning light will not come on. If other warning lights are working, voltage and ground is probably not the issue. (Still a good idea to check it.) Do you have a ground on the appropriate pin for that warning switch? No? The problem is not the box or panel. Yes? The control box or panel is most likely the issue.

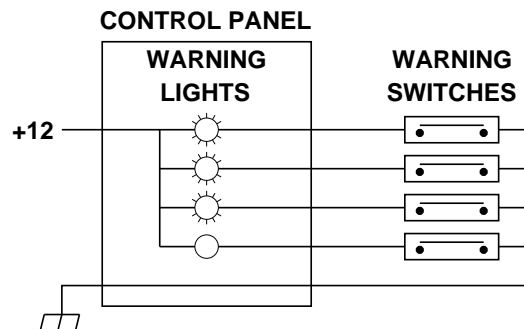

Fig. 13

On 325 series long board manually controlled leveling systems and all automatic systems from the 510 series system on, there is no good way to diagnose a problem that is isolated to either the touch panel or control box. These systems use multi-plex communications between the box and touch panel. There is no way to use a test light or multi-meter to check the communication signals between the box and touch panel. The only thing that can be done is to check the cable connecting the two. The cable can be checked for continuity from end to end and to make sure no wires are shorted to ground or together. Sometimes it will be necessary to try a different touch panel and if that is not the problem, then change the control box.

Another thing that is important to note about control boxes is that normally there are multiple power sources for the control box. Usually, ignition power is used for the control box itself and there is switched or unswitched battery power into the control box for external loads such as solenoid valves. Some systems may have as many as four different power sources. Make sure to review these issues before beginning diagnostics.

**2-8 WARNING SWITCHES (jack down indicator switches).** Both the kick-down style and the straight-acting or fixed style jacks have a warning switch to indicate the jack is in the vertical position or extended. Most warning switches are very simple electrically except the switch used for the early 610 series leveling system jacks. This was a three wire switch with resistors and will be discussed separately in this section. All jack warning switches, including the three wire switches, simply complete a ground circuit. This ground is used to turn on a red jack down indicator light on the control panel along with some type of master warning indicator such as a light or buzzer. It is also used to supply jack down information to the computer processor in automatic, computerized leveling systems.

**2-8.1 Kick-down style jacks.** The kick-down jack warning switch indicates the jack has swung to the vertical position. It does not indicate the foot of the jack has extended or that the foot is on the ground. Originally, the warning switch was attached to the cylinder of the jack with a band clamp. The switch is now screwed to the pivot point of the jack. All kick-down warning switches, except the three wire kick-down warning switches, are two wire switches. The wires coming from the switch point up when the jack is horizontal and point down when the jack is vertical. The electrical part of the warning switch is a small canister inside the main body of the switch. This canister has a small steel ball inside along with two contacts that attach to the wires of the switch. One wire is connected to ground and the other wire goes to the control panel or control box to supply a ground for the warning light circuit for that particular jack. As the jack swings to the vertical position, the ball in the switch rolls into the two contacts of the switch completing the circuit. This supplies a ground for the jack warning light and the processor if applicable. These switches can be adjusted to come on sooner or not come on as soon by bending the switch up (light doesn't come on as soon) or down (light will come on sooner). Older kick-down switches contain a mercury switch and should be disposed of properly when replaced. The older switches function the same way the new switches.

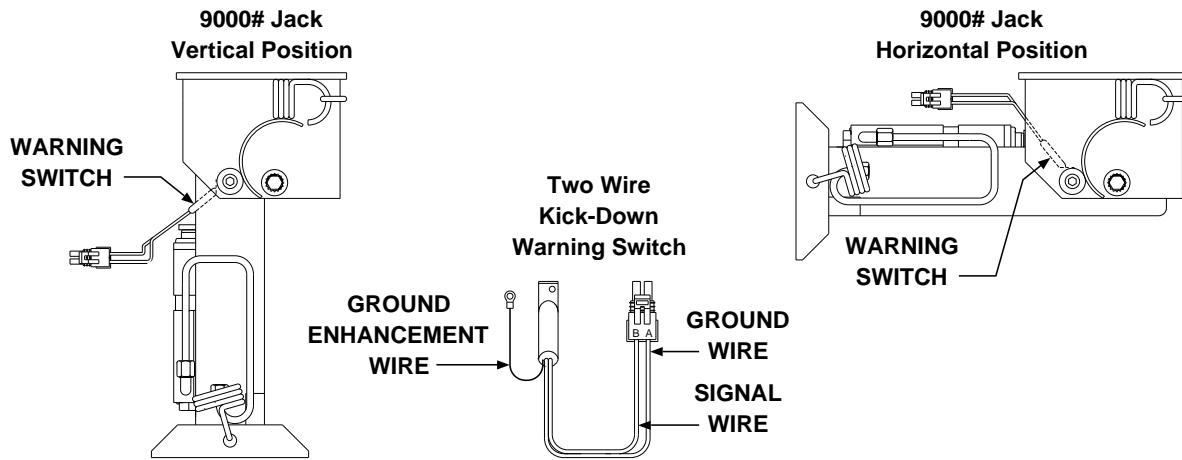

Fig. 14

The connection for the warning switch to the warning switch harness is presently a two pin Packard connector. The harness has two wires for the switch. One is the ground supply from the control box or panel the other is the “signal” wire for the warning light circuit at the control box or panel. Where the wires are inserted into the connectors for the harness and the switch, the connectors are labeled A and B. The ground wire is inserted in the A slot and the signal wire is inserted into the B slot. It is important that the wires are inserted into the correct slot. Newer switches have a small white wire with a ring terminal. The ring terminal goes under the screw that holds the switch onto the jack. This wire helps insure the cylinder of the jack is grounded. This is important on jacks with pressure switches used for automatic systems. The jack cylinder is normally grounded through the pivot bracket but the pivot point of the jack can create a weak ground connection for the cylinder due to dirt or corrosion, especially on jacks that may not be operated frequently.

Older kick-down switches are two wire switches but had either no Packard connector or a single pin Packard connector. Harness and ground connections were made with butt connectors, soldering or ring terminals. Replacement switches are supplied with an adaptor that allows you to connect to the existing harness and properly ground the switch. It is not recommended to use butt connectors unless the connection is covered with shrink tube when completed. Whatever type of connection is made, it needs to be waterproof. The ground connection will be a ring terminal and the important thing is to make sure the connection for the ring terminal is to clean metal and the completed connection is protected against corrosion.

**2-8.2 Straight-acting or fixed style jack warning switches.** The warning switches for straight-acting or fixed style jacks indicate the foot of the jack has extended slightly. As with the kick-down jacks, the switch does not indicate the foot of the jack is on the ground. The foot of the jack will extend between ¼ inch and 2 inches depending on the type of switch the jack uses. There are four different switches that have been used with straight-acting or fixed style jacks not counting the three wire switches that will be discussed later.

**2-8.2.1 The side port switch** was a single wire switch and as named, screws into the side of the jack cylinder. The switch has a spring that isolates two contacts when the jack is retracted. As the rod retracts into the barrel, the top of the rod hits the end of the switch, pushing the spring and end contact up. When the cylinder extends about 1 inch, the spring pulls the two contacts together supplying a ground from the body of the switch to the wire of the switch. The switch is a normally closed switch with the spring in the relaxed position. The switch wire should have a single pin Packard connector. The pivot point of a straight-acting jack with this switch can be a weak point for the ground circuit due to dirt or corrosion. Attaching a hose clamp/wire assembly to the jack cylinder and directly to the frame can help if this problem arises. Allow enough slack in the wire for the jack to pivot without putting a strain on the wire. Make all connections watertight to maintain a good ground.

Changing this switch will be difficult if the existing switch is removed with the jack retracted. The new switch cannot be inserted into the cylinder unless the cylinder is extended several inches. To replace a side port switch, extend the jack several inches. Remove the foot of the jack or place blocks between the foot and the barrel of the jack to prevent the rod from retracting. (When the switch is removed, the oil will be released from the jack and the rod will retract if not restrained.) Unplug and remove the switch from the jack and install the new switch. The switch needs to be tight but an o-ring seals the switch so be careful to not over tighten the switch. Do not use a thread sealant on the threads of the switch. Replace the foot and springs or extend the jack slightly so the blocks can be removed. If the switch is removed with the jack retracted, remove the spring from the end of the switch and use the old switch as a plug so the jack can be extended.

The drawings in Fig. 15 show the side port switch and also the 2 inch plunger warning switch. The plunger switch will be discussed next. Although neither of these switches is used in production at this time, replacement switches are still available.

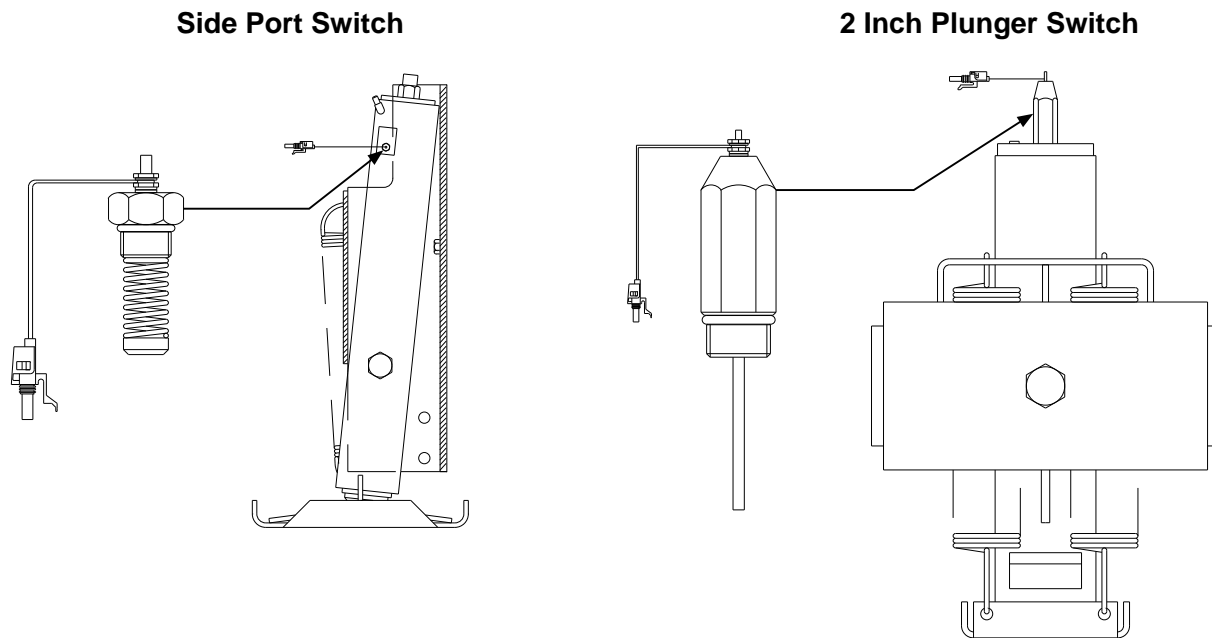

**Fig. 15**

**2-8.2.2 The 2 inch plunger switch** was also a single wire switch. This switch was only used with 24,000 lb. capacity jacks. The name of the switch says it all, the jack has to extend approximately 2 inches before the warning indicators come on. The plunger switch is a normally closed switch. The small rod coming from the bottom of the switch (opposite end from where the wire attaches) is the plunger. As the rod extends approximately 2 inches a spring in the switch pushes the plunger out allowing the contacts in the switch to close, which completes a circuit for ground from the body of the switch to the wire of the switch. This turns on the warning indicators. As the rod retracts, it pushes the plunger rod up which opens the contacts of the switch in turn opening the ground circuit. Like the side port switch, the pivot point of a straight-acting jack with a plunger switch can be a weak point of the ground circuit due to dirt or corrosion. Attaching a small band clamp/wire assembly to the switch and directly to the frame can help if this problem arises. Allow enough slack in the wire for the jack to pivot without putting a strain on the wire.

Depending on access issues, the replacement of a plunger switch is relatively simple. The only requirement is that the jack is fully retracted before removing the switch. Unplug the switch and unscrew the switch from the jack cylinder. A small amount of oil may come out of the top of the jack. Install the new switch and tighten. The switch seal is an o-ring so do not over tighten the switch. Do not use any type of thread sealant on the threads of the switch.

**2-8.2.3 The two wire magnetic warning switch** is the most recent type of warning switch. There are two versions of this switch. One has a **black** two pin Packard connector and the other has a **gray** two pin Packard connector. The switch with the gray connector is the only magnetic switch used for production now with all straight-acting or fixed style jacks. The connectors have keying slots so a switch with a black connector cannot be plugged into a harness with a gray connector. Neither can a switch with a gray connector be plugged into a harness with a black connector. Other than the connector, the switches look the same. The difference is the distance the jack will extend before the warning indicators come on.

The switch with a black connector will allow the jack to extend 1 to 1 ¼ inches before the warning indicators come on. The switch with a gray connector will allow the jack to extend ¼ to ½ inch before the warning indicators come on.

The magnetic warning switch is a normally closed switch. There is a magnet fixed to the top of the rod inside the jack. When the jack is retracted, the magnet is close to the switch. This opens the contacts so there is no ground circuit for the warning indicators. As the jack extends, the magnet moves away from the switch which allows the contacts to close. This provides a ground circuit for the warning indicators.

The harness has two wires for the switch. One is the ground supply from the control box or panel the other is the “signal” wire for the warning light circuit at the control box or panel. Where the wires are inserted into the connectors for the harness and the switch, the connectors are labeled A and B. The ground wire is inserted in the A slot and the signal wire is inserted into the B slot. It is important that the wires are inserted into the correct slot. Newer switches have a small white wire soldered to the ground wire of the switch and to the body of the warning switch. This wire helps insure the cylinder of the jack is grounded. This is important on jacks with pressure switches used for automatic systems. The jack cylinder is normally grounded through the pivot bracket but the pivot point of the jack can create a weak ground connection for the cylinder due to dirt or corrosion, especially on jacks that may not be operated frequently. Replacing an existing warning switch without the small white wire with a new switch will solve a grounding problem on an older jack.

Replacing a magnetic warning switch requires the jack to be fully retracted. Removing a warning switch with a jack extended will cause a considerable mess and could be a hazard if the vehicle is supported by the jack. The jack will retract if the switch is removed. To replace the switch, unplug the switch and unscrew the switch from the jack. Install the new switch and be careful to not over tighten the switch. The switch uses an o-ring seal. Plug the switch in and test the system.

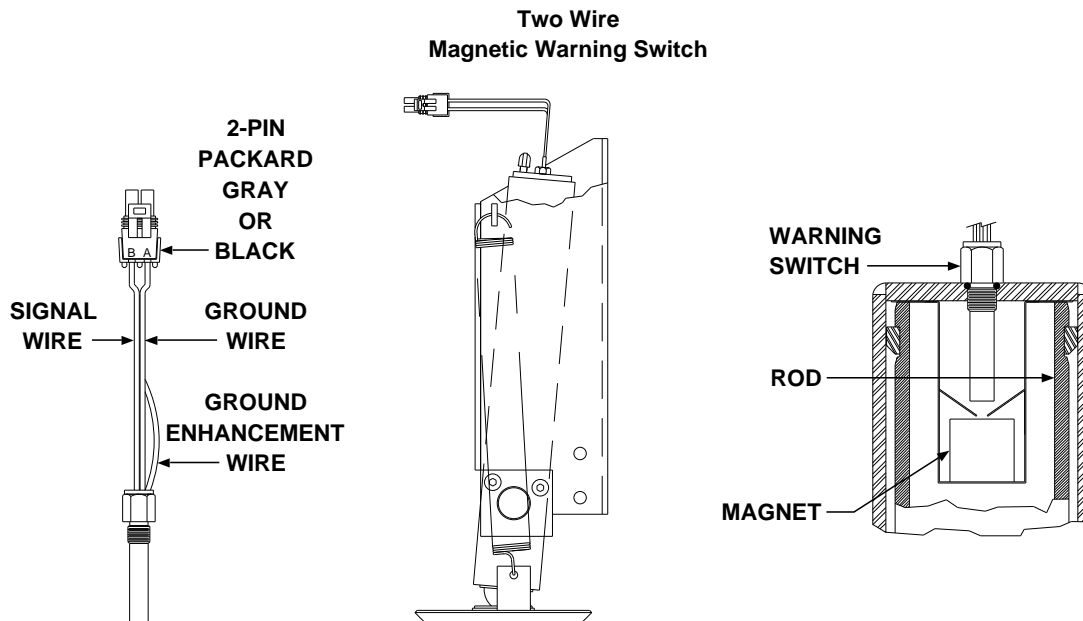

**Fig. 16**

**2-8.3 One and two wire warning switch diagnostics.** Warning switch diagnostics is usually a simple process of elimination. Start by isolating the circuit *or circle*. The main components of the circuit are the warning switch, the harness and the control box, light plate or control panel. The following diagrams show three circuits; a central grounded two wire warning switch (this would be what is presently being used), a non-central grounded two wire warning switch and a non-central grounded one wire warning switch. They are drawn with the switch open as if the jack would be retracted. The warning light would be off.

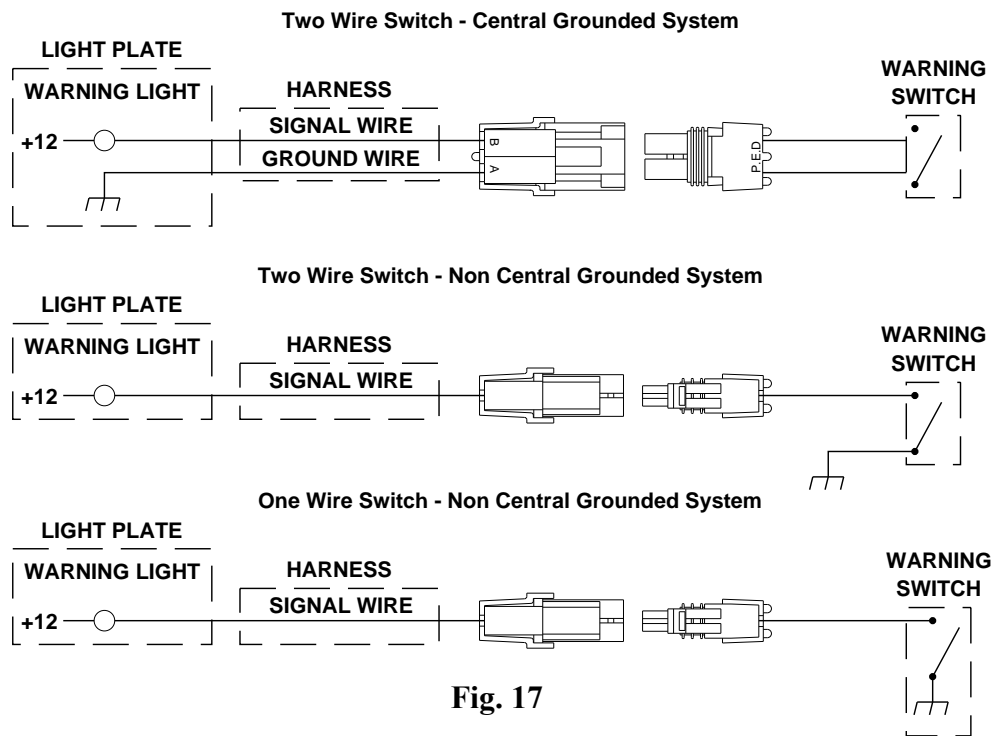

**Fig. 17**

On newer systems (since about 1994) the warning switches are centrally grounded at one main location with the rest of the grounds needed for the system, both for manual and computerized automatic systems. On older kick-down jack systems and single wire switches for straight-acting and fixed jacks, the grounds for the switches are dependent on the jack mounting and/or the pivot point of the jack. Warning switch repair on an older system may involve cleaning the warning switch ground wire connection to the frame or jack bracket or the addition of a ground wire to the cylinder for one wire switches.

Warning switches have only two positions. If the jack is retracted, the switch contacts should be open and the warning light for that jack should be off. If a kick-down jack is vertical or a straight-acting/fixed jack is extended slightly (1/4 to 2 inches depending on the jack and typed of switch) the switch contacts should be closed and the warning light for that jack should be on.

**2-8.3.1 If a jack is retracted and the warning indicators will not go out,** just unplug the switch or separate the harness from the warning switch on older systems and see if the indicators go out. If they do, the problem is at the switch. If the switch in question is a magnetic switch, remember there is a magnet in the jack that opens the switch contacts. The magnet could be the problem. If the indicators don't go out with the switch unplugged, the signal wire in the harness is shorted to ground or there is a problem with the light plate, control panel or control box. For the newer two wire switches with the small ground enhancement wire, make sure the ground wire in the switch and harness plug are in the A slot. If the wires are reversed in either the switch or harness plug, the warning indicators will be on all of the time when the switch is plugged into the harness. When the wires are reversed in one of the plugs, there is a direct ground on the signal wire as long as the pivot point of the jack has good conductivity to ground. Remember, the ground enhancement wire on the switch takes care of a weak ground point that may be at the pivot point of the jack. If using a meter to check the switch when the jack is retracted, the meter should show the switch totally open.

**2-8.3.2 If a kick-down jack is in the vertical position or a straight-acting/fixed jack is slightly extended, and the warning indicators are not on,** again unplug the switch or separate the switch from the harness. Locate a good ground point and ground the signal wire in the harness. This would be the wire in the B slot of a two wire harness. If the warning indicators come on, the problem is at the switch. If the indicators don't come on, the problem is the harness or the light plate, control panel or control box. For two wire switches, you should be able to short the two pins in the harness plug together and turn the warning indicators on. If the indicators come on, the problem is the switch. If the indicators don't come on, the problem is the ground in the harness, the signal wire in the harness or the light plate, control box or control panel. Using a meter to check for continuity through the switch to ground is not usually necessary. Grounding the signal wire (B wire) in the harness will give you the information you need.

**2-8.4 3 wire warning switches.** The 3 wire switches are only used on jacks for the early 610 series leveling systems that **ARE NOT** centrally grounded. There are two basic types of 3 wire switches. There is a switch for the kick-down jacks and one for straight-acting or fixed jacks. The early version of these switches had two single pin Packard connectors and a long ground wire with a ring terminal. The single pin shroud connector was for the jack pressure switch. The single pin tower connector was for the harness connection. On present switches, the ground wire is in a two pin tower connector with the signal wire for the switch. The jack pressure switch connector is still a single pin shroud connector. Early systems will have only one wire, the signal wire, to each jack in the harness. The later systems have two wires in the harness, a ground wire for the warning switch and the signal wire. Replacement 3-wire warning switches come with an adaptor that will connect a warning switch with a 2-pin Packard connector to a 1-wire harness with a single pin Packard connector or no connector.

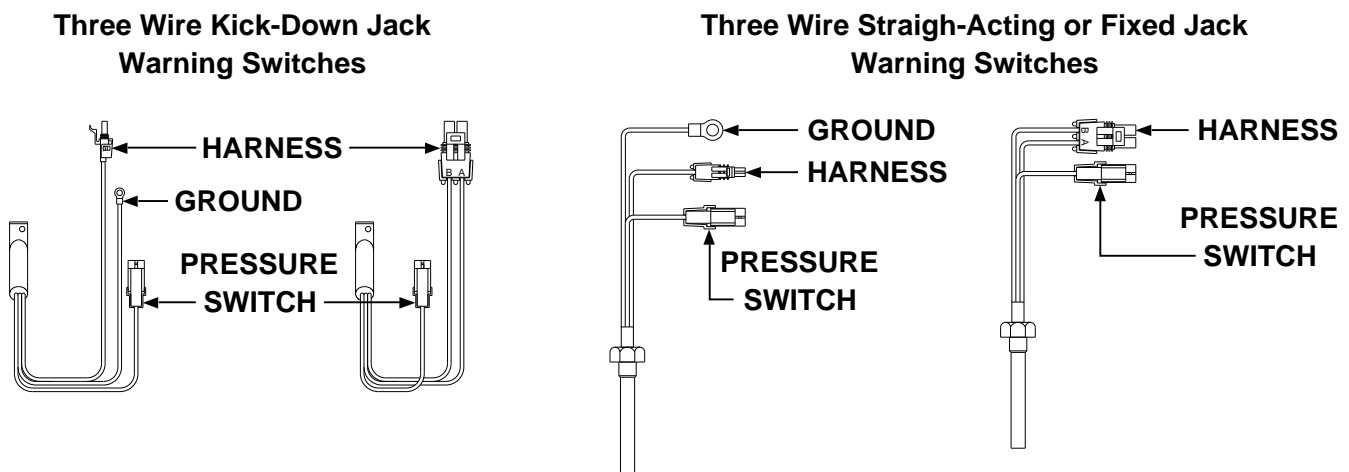

**Fig. 18**

The 3-wire warning switch was developed to allow the use of one signal wire in the harness to each jack even though each jack has two information switches. Each jack has a warning switch and a pressure switch. The warning switch is for the jack down warning lights and the pressure switch is used during the stabilizing mode of automatic leveling to let the computer know the jack is on the ground. The 610 non-central grounded leveling system will be discussed in greater detail in Lesson 13 of the HWH ONLINE SCHOOL.

The 3-wire warning switch has two resistors incorporated into the assembly. There is a 430 ohm resistor on the warning switch wire and a 100 ohm resistor on the pressure switch wire. These two resistors end up in a parallel circuit when both the warning switch and the pressure switch are on. The total resistance in this circuit is approximately 81 ohms. If only the warning switch is on, the circuit resistance is 430 ohms. The following diagrams show the 3-wire switch circuit in three steps, both switches off, with only the warning switch on and with both the warning and pressure switches on.



The diagrams show what the resistance values will be when measuring at different points on the switch. Actual measured values should be within between 5 and 10 percent. The switch circuit is the same for the kick-down or straight-acting style warning switch with either a single pin or 2-pin Packard connector.

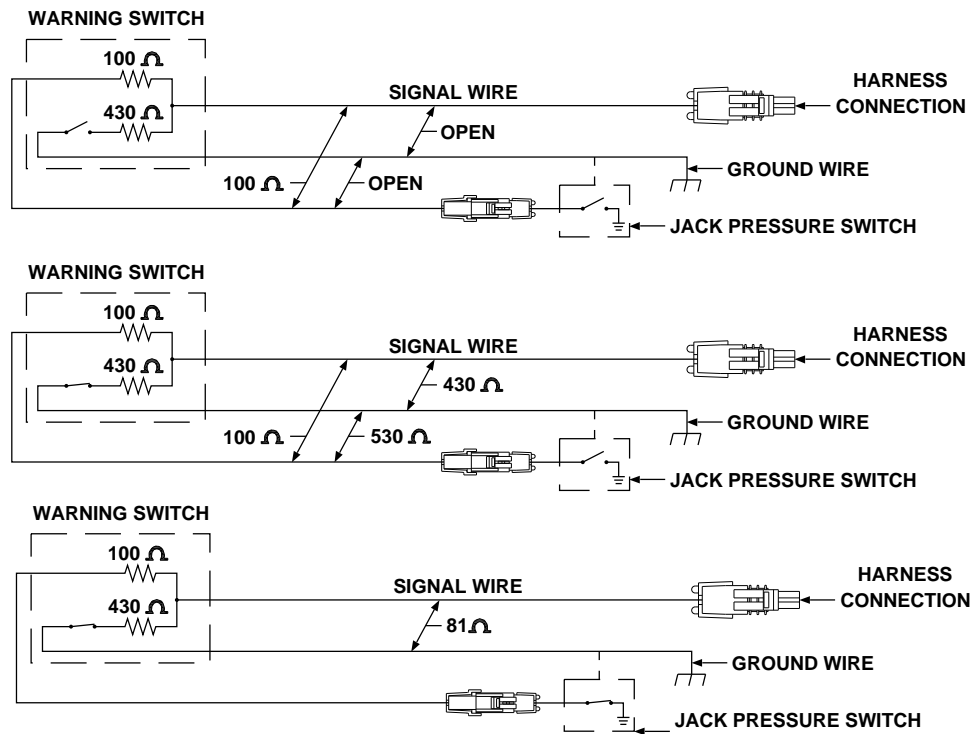
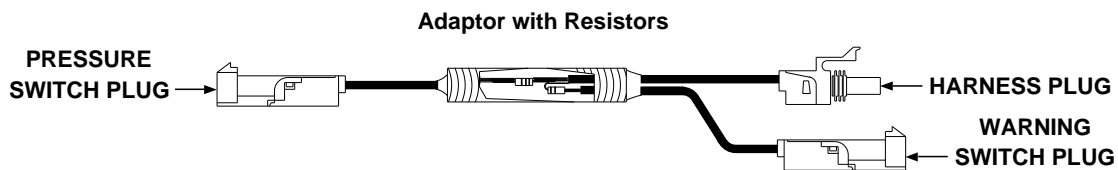

**Fig. 19**

**2-8.4.1 3 wire warning switch diagnostics.** The basic diagnostics for a 3 wire warning switch is the same as other warning switches. The function of the switch is to have open contacts so the warning light is off or have the contacts closed to turn the warning light on. If a jack is retracted and the warning light for that jack remains on, unplug the pressure switch from the warning switch. If the warning light goes out, the pressure switch is stuck on. If the warning light remains on, unplug the switch from the harness. If the warning light goes out, the problem is the warning switch or possibly the magnet with a straight-acting style jack. If the light does not go out, the signal wire (or the B side in a two pin plug) in the harness is shorted to ground or there is a problem with the touch panel or control box.

If a warning light will not come on when a jack is extended or vertical, unplug the harness and ground the signal wire (B side of a two pin plug). If the warning light comes on, the problem is the warning switch or the grounding of the warning switch. If the warning light does not come on, the problem is the wire in the harness, connections, the touch panel or the control box.

Some straight-acting jacks used with the 610 series non-central grounded system used the single wire side port or 2 inch plunger warning switches. A special adaptor with resistors built in is used with this type of system. The diagnostics remain the same as above. Simply unplug switches or ground wires to test the warning light circuit.



**Fig. 20**

The systems with three wire warning switches can experience severe grounding issues that can make the system operate very erratically during the automatic leveling procedures, especially during the stabilizing mode. For complete diagnostics of the 3-wire warning switch and pressure switch circuit, along with detailed instructions for grounding this system refer to ML9138 in the service manual section of the HWH web site.

**2-9 PRESSURE SWITCHES.** HWH uses pressure switches for many different reasons. Pressure switches are used with hydraulic leveling systems, room extension systems and air leveling systems. At this time, all pressure switches are used to complete a ground circuit except the pressure switches used on our air compressor assemblies used in air leveling systems. Pressure switches can be a one wire or two wire switch. The one wire switch is an internally grounded switch. These switches rely on a good ground through the piece of equipment they are attached to. Two wire switches rely on a ground supply wire in the harness. Some of the switches we use are produced by HWH but not all. We have used hydraulic pressure switches in the past that were produced by a different manufacturer and the pressure switches we use on air leveling systems are also produced by a different manufacturer.

The following are some of the pressure switches that have been used or that are still being used by HWH. There have been a few other different pressure switches used but these were/are the most common. All switches used by HWH can be diagnosed the same as these switches.

**Two wire air pressure switch used on air manifolds and air compressors. This switch is no longer used. It can be replaced with a new style air pressure switch.**

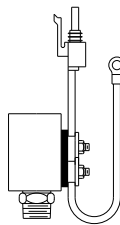

**Two wire air pressure switch used on air manifolds and air compressors. This switch is the current switch that is being used. It is available in several different pressure ratings.**

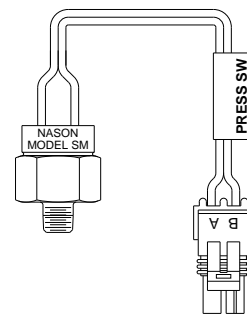

**Adjustable air pressure switch used only on air compressors. This switch comes with no wires and is wired during the assembly of the air compressor.**

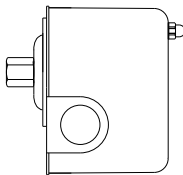

**Two wire hydraulic pressure switch. This switch was used primarily on leveling system manifolds. The normal setting for this switch is 3000 psi.**

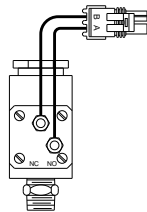

**One wire hydraulic pressure switch. This switch is produced by HWH. It is used on jacks, leveling or room manifolds and some synchronizing cylinders. The part number and pressure rating of the switch is identified on a part tag on the wire of the switch near the Packard connector.**

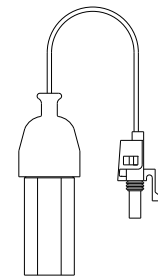

**Fig. 21**

**Important note: All one wire hydraulic pressure switches look the same. It is important to get the proper switch when replacing a hydraulic pressure switch.**

Pressure switches, like other types of switches, can be normally open or normally closed. A **normally open pressure switch** will have open contacts with no pressure. The contacts will close as the desired pressure is reached. Example: The 50 psi pressure switch on the hydraulic manifolds has normally open contacts. The circuit is open. When the pressure in the manifold reaches 50 psi, the contacts close which completes the circuit.

A **normally closed pressure switch** will have closed contacts with no pressure. The contacts will open as the desired pressure is reached. Example: The 20 psi pressure switch on an air leveling manifold has normally closed contacts. The circuit is complete. When the air pressure in the manifold is approximately 20 psi, the contacts of the switch will open. This will create a break in the circuit.

Pressure switches also have what is called a hysteresis. The quick explanation of hysteresis is: *the pressure the contacts of the switch open and close at is slightly different*. Example: The contacts of a 20 psi air pressure switch close at 20 psi. The pressure the contacts open at is slightly less, approximately 18 psi. In most cases, the hysteresis of the switch is not important for diagnostic purposes. The pressure differences we deal with in the systems are great enough that the hysteresis of the switch will not be noticeable. **The contacts of normally open switches will close on a rise in pressure. Example:** The 3000 psi hydraulic manifold pressure switch contacts will close as the pressure increases to 3000 psi. **The contacts of normally closed switches will close on a fall in pressure. Example:** The contacts of the 20 psi air manifold pressure switch will close when the pressure drops to 20 psi.

The only pressure switch that the hysteresis of the switch is important enough to note on diagrams or when performing diagnostics, is the air pressure switches used on air compressors for our air leveling systems. There are several types of pressure switches that are used and several different amounts of hysteresis in the switches. The contacts of an air compressor pressure switch will close as the pressure drops to a certain level. The contacts will open as the pressure increases to the desired level. Example: On the AP0198 air compressor, the pressure switch contacts will close when the pressure drops to 70 psi. This will turn the air compressor on. (If needed) The contacts of the switch will open when the pressure rises to 90 psi. This will turn the air compressor off. When diagnosing air compressor problems, it may be important to obtain the open and close pressures of the air compressor pressure switch.

Pressure switches are used in the systems for several different reasons. A pressure switch can be used as an **information switch, a limiting or safety switch or can be used as a warning switch**. The following list is the different switches used in our hydraulic and air systems.

**2-9.1 Jack pressure switch:** Jack pressure switches are a single wire switch produced by HWH. It is used as an information switch. The switch is a normally open switch and completes a ground circuit when the switch contacts close. Jack pressure switches, for the most part, do not have a specific pressure rating. The exception to this is a jack pressure switch set at 550 psi. This switch has its own part number. The switch setting depends on the size of jack and the weight of the vehicle. Jack pressure switches are adjustable and may need to be adjusted after installation. Switches installed at HWH on larger jacks are set at a higher pressure, but the replacement switches (except the 550 psi switch) are all the same setting, 140 psi. Jack pressure switches are used to let the system computer know that jack is on the ground. Most jack switches are used on computerized leveling systems during the stabilizing part of the leveling procedure. On towable units, the front jack pressure switches must be on to start an automatic leveling or store procedure.

**2-9.2 3000 psi hydraulic manifold pressure switch:** The 3000 psi manifold pressure switch is a single wire switch produced by HWH. This switch is an information switch. Older systems may have a two wire switch that was not produced by HWH. These switches can be replaced by the new 3000 psi switch. A few very early computerized systems had a 2500 psi switch. The 3000 psi switch is a normally open switch and completes a ground circuit when the contacts of the switch close as the system pressure reaches 3000 psi. Although the switch is adjustable, this should not be necessary. The 3000 psi manifold switch is only used on computerized hydraulic leveling systems or on room extension systems which have hydraulic locks or room systems with room in/out limit switches and air seals. Normally the switch is on the leveling system manifold but may be on a room extension manifold if the vehicle does not have HWH hydraulic leveling. The 3000 psi manifold switch monitors system pressure and is used to indicate an “excess slope” situation during automatic leveling.

**Example:** The two front jacks have extended as far as they can and the front yellow level light is still on. When the system pressure reaches 3000 psi and the switch contacts close, the controls stop the leveling procedure and turn on the “EXCESS SLOPE” light. With room extension, the controls must see the 3000 psi system switch when changing a sequence. **Example:** When the controls see an unlock switch, they must also see the 3000 psi system pressure switch before going to the next sequence, room extend or room retract. The same is true with the room in/out limit switches. When the controls see a room in switch, they must also see the 3000 psi system pressure switch before engaging a room lock or shutting the pump off.

**2-9.3 50 psi hydraulic manifold pressure switch:** The 50 psi manifold pressure switch is a single wire information switch produced by HWH. This switch is only used on 310 series, 305/325 series, 625 series and 2000 series leveling systems. This switch is a normally open switch and completes a ground circuit when the contacts of the switch close as the system pressure reaches 50 psi. This switch must be installed on the manifold so it comes after the shuttle valve in the hydraulic circuit. The 50 psi manifold switch is used to let the controls know the shuttle valve has shifted and jack solenoid valves can be opened. With manual leveling systems jack solenoid valves cannot be opened electrically until the controls see the 50 psi manifold pressure switch.

**2-9.4 5000 psi hydraulic synchronizing cylinder pressure switch:** The 5000 psi sync cylinder pressure switch is a safety switch that is only used on four cylinder room extension systems. The 5000 psi switch is a normally open single wire switch produced by HWH. Some four cylinder sync cylinders used a two wire, 4000 psi pressure switch. There is one pressure switch on each chamber of the sync cylinder for each room cylinder. Each switch is a normally open switch and completes a ground circuit when the contacts of the switch close as the pressure between the sync cylinder and a room cylinder reaches 5000 (4000) psi. This switch is important because if a four cylinder room extension cylinder jams during a cylinder retract procedure, the pressure between the sync cylinder and the jammed cylinder can exceed 10,000 psi. This will certainly damage cylinders and hoses. If the pressure reaches 5000 (4000) psi, the sync cylinder pressure switch contacts close. This opens a Bosch relay on the pump motor and turns the pump motor off. ***Never operate any four cylinder room extension if any one of the four 5000 (4000) psi sync cylinder pressure switches are unplugged.***

**2-9.5 Air compressor air pressure switch:** The air compressor pressure switch is a normally closed two wire information or control switch. This is the only pressure switch used by HWH to switch a positive voltage. This switch is used to keep the compressor off unless the vehicle system pressure drops below a specific level. There have been several different switches that are or have been used. One of the switches is a set pressure that cannot be changed and the other switch is an adjustable switch. It is also the only switch that the hysteresis of the switch is considered important. Hysteresis is the difference in pressure where the switch contacts open and close. This will be explained in detail a little later in this section, 4.9. When system air pressure is low, usually between 70 and 85 psi, depending on the switch, the switch contacts are closed and positive voltage transfers through the switch contacts to the contacts of the compressor relay. If the compressor relay is on, the air compressor will run. As the system air pressure increases to somewhere between 90 and 120 psi, again depending on the switch, the switch contacts open. This will eliminate positive voltage from the compressor relay coil and the air compressor relay will turn off. The compressor will not run, even if the system controls are sending a signal to turn the compressor on.

**2-9.6 Air bag air pressure switches:** The air bag pressure switches are on air manifolds used in HWH air leveling systems. These switches have all been normally closed, two wire switches. Present switches are a potted switch with a two pin Packard connector. The air bag pressure switches are used to complete a ground circuit when the contacts are closed. There are different arrangements of air bag pressure switches but the most common is one switch for each side of the front axle or suspension, one switch for each side of the drive axle. Different ratings of the air bag pressure switches are used.

There are 10 psi, 20 psi and 35 psi air bag pressure switches. And there may be a combination of these used on the same vehicle. These switches have dual functions. First, they are used as a warning switch. If a bag pressure drops to the switch rating, the contacts close which completes a ground circuit to the control system. This will turn on warning indicators. The other purpose of the air bag pressure switches is to keep the vehicle from twisting during a lower procedure. There are other programs but the most common program is this: If either front air bag switch is on (contacts closed), a front lower function will halt or cannot be performed, either manually or in the automatic mode. If either rear (drive axle) air bag switch is on (contacts closed), a rear lower function will halt or cannot be performed. Tag axle air bag pressure switches do not inhibit any leveling function and are only used as warning switches. Air bag pressure switches do not inhibit any raise function.

**Note: When an air bag pressure switch is acting as a warning switch, there is a delay in the control system between the time the switch contacts close and the warning indicators come on.**

Air leveling system programming tends to change from time to time. For systems produced after 2008, contact HWH Technical Services for current program information.

**2-9.7 System air pressure switches:** The system air pressure switch is a warning switch only used on the drive axle air manifolds. They are teed into the air supply fitting at the air manifold from the vehicle air system. These switches are normally closed two wire switches. Present switches will have a two pin Packard connector. Older switches may have a single pin Packard connector with the other wire having a ring terminal that is attached to the manifold. The system pressure switch will complete a ground circuit when the vehicle system air pressure drops to the rating of the switch. There are several different rated switches used. There is an 85 psi switch and a 100 psi switch. The system pressure switch is only used as a warning switch. When system pressure drops to the switch rating, the contacts of the switch close. This completes a ground circuit to the control system. The control system will then turn the warning indicators on. Unlike the air bag pressure switches, there is no delay between the switch contacts closing and the warning indicators coming on.

In wiring diagrams in owners and repair manuals, pressure switches are simply drawn as they physically look. When drawn in schematics, we use the following symbols. The pressure rating is listed next to the switch.

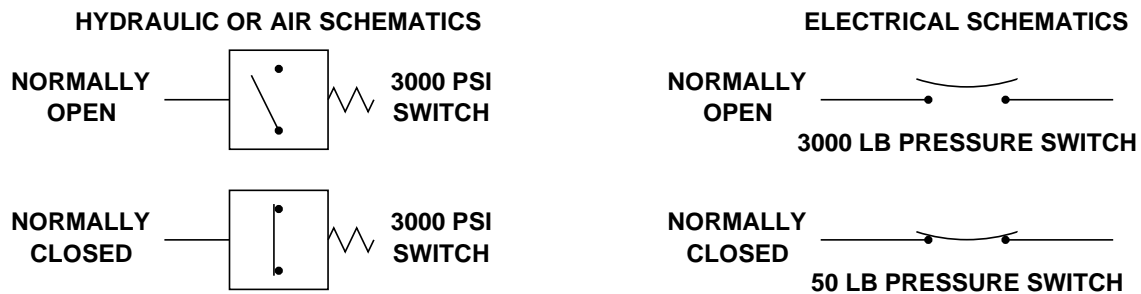

**Fig. 22**

**2-9.8 Pressure switch diagnostics.** Pressure switch diagnostics is much like diagnosing a warning switch; all the pressure switch does is open or close a circuit. Most of the diagnostics can be done with a test light, continuity tester or some jumper wires. In some cases, it may be necessary to have a pressure gauge available. When testing hydraulic pressure switches, the gauge needs to be capable of at least 5,000 psi. Most air systems we deal with would not exceed 150 to 200 psi. It is important to know if the switch is switching a ground or a + voltage. This information can be found in repair manuals or in wiring diagrams.

**Normally open pressure switches.** A normally open pressure switch should be totally open with 0 pressure in the system. If the switch is a two wire switch, the circuit should be open between the two wires of the switch. If the switch is a one wire switch, the circuit should be open between the switch wire and the body of the switch. When testing the continuity of the switch, it is best that the switch is unplugged. When the pressure in a hydraulic or air circuit reaches the rated pressure of the switch, the switch contacts should close. There should now be continuity through the contacts of the switch.

**Normally closed pressure switches.** A normally closed pressure switch should have very low resistance between the switch contacts with 0 pressure in the system. A two wire switch will show a closed circuit with little resistance between the two wires. A one wire switch will show a closed circuit with little resistance between the wire and the body of the switch. When testing the continuity of the switch, it is best that the switch is unplugged. When the pressure in a hydraulic or air circuit drops to the rated pressure of the switch, the switch contacts should close. There should be continuity between the contacts of the switch.

Knowing the function of the pressure switch will help determine if a pressure gauge is needed for the proper diagnostics of the switch. **Example 1:** A jack pressure switch is not functioning correctly. You do not need to take a pressure reading at the jack, a jack pressure switch should close when the jack has lifted the vehicle approximately 1 inch. The pressure at which this is achieved is not important, only that the vehicle lifts about 1 inch. **Example 2:** An automatic system will not show excess slope even though two jacks are fully extended and the vehicle is not level. It will be necessary to determine that the system can develop more than 3100 psi. The pressure switch will not close until the system reaches 3000 psi and the switch can be set at + or – 100 psi. The problem may be the switch but could also be a shuttle valve or the pump itself.

Pressure switches may have some tolerance. This would allow the switch to open or close at a slightly different pressure than the stated operating pressure of the switch. A 20 psi air pressure switch may operate at 19 or 21 psi. A 3000 psi hydraulic pressure switch may operate at 2900 or 3100 psi. If the stated pressure and actual operating pressure of a switch seems too extreme, contact HWH to obtain switch tolerance information.

**2-10 LIMIT SWITCHES.** Limit switches, for HWH, are only used with room extensions or other type of slide out systems. We use room in and/or room out limit switches, floor up/floor down limit switches, lock/unlock limit switches and clamp retracted limit switches for our electric travel clamps. We also use a vacuum switch on some air seal vacuum manifolds.

Limit switches are used to supply the system controls with information about the position of the equipment the switch is used for. This information is critical not only for the proper operation of a room or slide mechanism but also to prevent damage to the mechanism. Having a locking mechanism extend while a slide mechanism is moving will create an obvious problem.

HWH uses several types of limit switches. We use several styles of simple magnetic switches. We use the electronic Hall Effect switch. This switch is also activated with a magnetic field. We also use several different mechanical switches. The following are our presently used limit switches and their most common use.

**MAGNETIC ROOM POSITION SWITCH-NORMALLY OPEN CONTACTS**



**MAGNETIC PREVOST ROOM LOCK POSITION SWITCHES-NORMALLY OPEN CONTACTS**

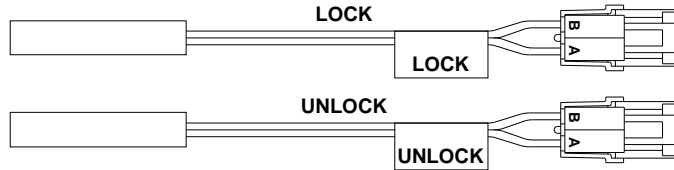

**MAGNETIC STANDARD ROOM LOCK POSITION SWITCHES-NORMALLY OPEN CONTACTS**

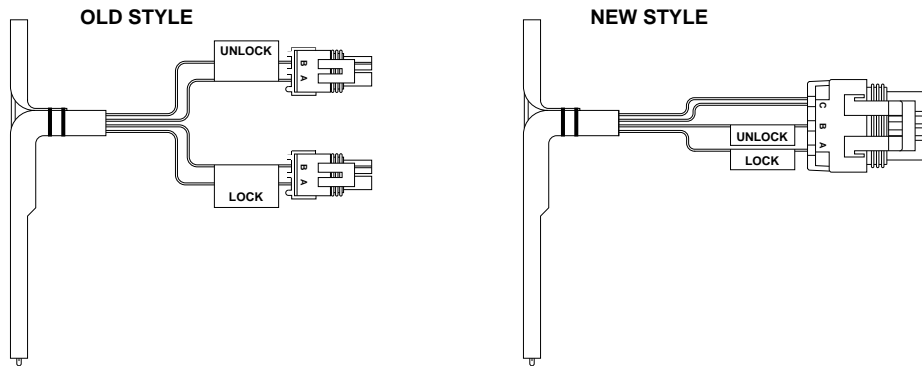

**3-WIRE HALL EFFECT ROOM POSITION SWITCH**

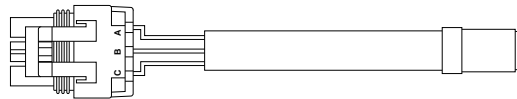

**SINGLE POLE -NORMALLY OPEN OR NORMALLY CLOSED  
MECHANICAL ROOM POSITION SWITCH**

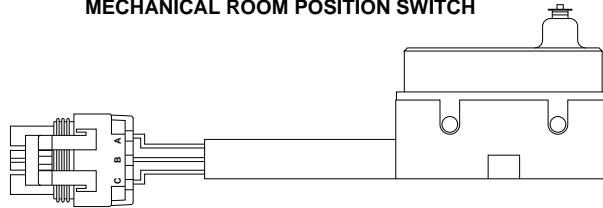

**MECHANICAL TRAVEL CLAMP POSITION SWITCHES**

**SINGLE POLE  
WIRED NORMALLY CLOSED**

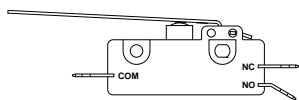

**DUOBLE POLE  
ONE SIDE NORMALLY CLOSED  
ONE SIDE NORMALLY OPEN**

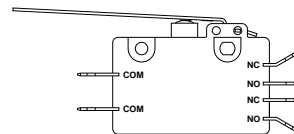

**Fig. 23**

Some limit switches are used to switch positive voltage and others switch ground. It is important to check wiring diagrams to determine what type of circuit the switch contacts are completing. Many of our room and lock limit switches do switch a positive voltage circuit. In the case of a cut or pinched wire, a fuse will blow instead of giving the controls a false reading of a completed ground circuit. Magnet and/or switch positioning is also important so the switch is not made too soon or not made at all.

**2-10.1 Limit switch diagnostics.** Before diagnosing limit switches make sure what kind of switch it is along with how and when the switch should function. Is the switch a room in or out switch, a floor up or down switch or is the switch a lock or unlock switch. Is it a magnetic, mechanical or Hall Effect switch? Should the switch function as a normally open or normally closed switch? Although the switches shown above give that information, it is important to remember there can always be exceptions to the rule. Does the switch complete a ground circuit or a positive voltage circuit? When you have this information, diagnosing the switch, even the Hall Effect switch should be simple.

Another important thing to consider when diagnosing limit switch problems is the adjustment of the switch. A large percentage of the time, the switch problem will turn out to be an adjustment problem. Make sure the magnet and switch are positioned properly. If the switch is a mechanical switch, the switch arm or the switch activating cam may need to be adjusted. It is also very important to make sure the room, floor, lock or seal are actually in the correct position for the switch to read. Rooms, especially with locks, will have a sequence that must happen for the room to operate properly. Sometimes the sequence involves the 3000 psi pressure switch with a limit switch before the sequence can continue. The problem may not always be the limit switch.

**Mechanical and magnetic limit switches.** These switches are like any switch. If the switch has normally open contacts, there should be no continuity from one side of the switch to the other when the switch is not activated. If the switch has normally closed contacts, there should be continuity between the contacts with very little resistance when the switch is not activated. The position of the switch contacts should change when the switch is activated.

**Example 1:** The switch is a magnetic room position switch to detect when the room is retracted. The switch is a normally open switch. The switch completes a ground circuit. As the room is retracting, there should be no ground on the signal wire of the switch. When the room becomes completely retracted, the magnet should line up with the switch. The contacts of the switch should close and there should be a ground on the signal wire of the switch. **Example 2:** The mechanical switch on an automatic travel clamp is a normally closed switch. With the travel clamp completely retracted, the switch is activated and the contacts should be open. When the clamp has extended slightly, the switch contacts should be closed. Because of the nature of this circuit that involves some diodes, the switch should be tested with the wires to the switch unplugged. This switch completes a ground circuit when the clamp is extending and a positive voltage circuit when the clamp is retracting. Because of the diode in the circuit, when extending the clamp, there would be a ground on both sides of the switch even with the clamp fully retracted.

**Hall Effect limit switches.** The Hall Effect switch is a solid state electronic switch that reacts to a magnetic field. The Hall Effect switch is used as a room position switch. The switch we use acts as a normally open switch that completes a ground circuit. The switch has three wires, a positive voltage wire, a ground wire and a signal wire. These switches all use a 3-pin Packard connector. The pins of the connector are labeled A, B and C. A is the ground wire. B is the + voltage for the switch. C is the signal wire. Most (if not all) controls will have indicator lights to show incoming signals. **Do not check the signal wire of a Hall Effect switch with a test light. Damage to the switch may occur.**



When a magnet is close to the switch, the switch is activated. This puts a ground on the signal wire. Make sure the room is in the proper position, fully extended or retracted. Most (if not all) controls will have indicator lights to show incoming signals. Check the appropriate indicator light. If the light is on, the switch is not the problem. If the light is not on, the proper way to check the switch is to first check for ground and positive voltage on pins A and B. Unplug the switch while testing. If either is missing, that must be addressed first. The switch cannot function without power and ground. If both are present ground the signal wire (pin C) in the harness. Check the control box to see if the controls recognize the ground signal. If the controls are seeing the ground signal, plug the switch back in and use an external magnet to activate the switch. Again, check the indicator light. If the indicator light is on, the switch is working. The problem is most likely the position of the switch or magnet. Adjust as necessary. If the indicator light does not come on, the switch is faulty.

**Vacuum switch for air seal manifolds.** This is a normally open switch that will complete a ground circuit when the contacts close. With no air exhausting from the manifold, the contacts of the switch should be open, no continuity between the wires of the switch. With air exhausting from the manifold and the air seal fully deflated, (this is a visual check) the contacts of the switch should close, completing a ground circuit. It may take several seconds after the air seal is fully deflated to activate the vacuum switch. Not all air seal manifolds will have a vacuum switch.

**2-11 SOLENOID VALVES-HYDRAULIC AND AIR.** Solenoid valves are used to direct the flow of fluid or air in our leveling systems and slide mechanisms. Solenoid valves consist of some type of seat and an electric coil. When the coil is energized, the seat is activated to open or close, depending on the type of valve. When the coil is de-energized, a spring moves the seat back to its normal off position. All valves except one hydraulic valve are controlled by switching the + voltage side of the circuit. HWH manufactures all of the hydraulic valves that used but none of the air valves. We will discuss the different types of hydraulic and air valves separately. We will then discuss the diagnostics of the valves jointly.

**2-11.1 Air solenoid valves.** We presently use seven different style air valves but there are multiple part numbers for some of these basic valves. The difference in the valves is the wire connections for the valve. All of our air valves are two wire valves. One valve may have a ring terminal on one wire and a Packard connector on the other. A different part number valve that uses the same basic valve may have two ring terminals. Other than changing wire ends, these valves are totally interchangeable. Older systems had harnesses with one wire going to each air leveling valve. The ground for the valve was done right at the manifold. Adaptor wires are available to adapt valves with two pin connectors to the old single pin harnesses. None of our air valve have a “back emf” diode built into the valve so either wire of any of the air valves can be + voltage or ground. (See section “4.2 Electric coils” for an explanation of the back emf diode.)

The following are the seven basic valves. Valves on older systems may look slightly different due to a different coil arrangement that was used. All of these valves have 12 volt coils:

**AP1940 AIR VALVE**

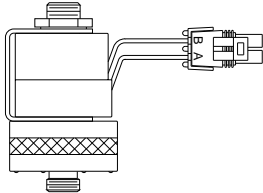

This is a normally closed valve and is activated by switching + voltage. This valve is the primary valve used on basic air leveling manifolds but is also used on air seal manifolds. Valves supplied before the mid-90s had a different coil arrangement.

**AP25428 HI-FLOW AIR VALVE**

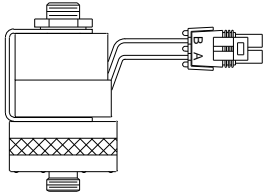

This is a normally closed valve and is activated by switching + voltage. This is a high flow valve and is used on tag axle air manifolds. This valve is not interchangeable with other hi-flow valves. **Be careful not to confuse this valve with the AP1940 valve. There is no visible difference between the two valves.**

**AP31928 HI-FLOW AIR VALVE**

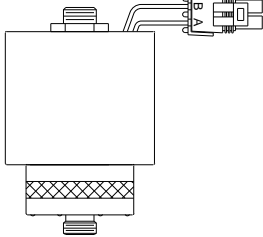

This is a normally closed valve and is activated by switching + voltage. This is a high flow valve and is used on active air system manifolds. This valve should not be interchanged with other hi-flow valves.

**AP31930 3-WAY AIR VALVE**

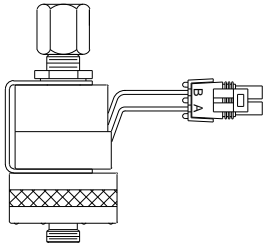

This valve will flow air through the top port when not activated. When activated, the top port is closed and the manifold port is open. This valve is activated by switching + voltage. This valve is used on tag axle air manifolds for the tag lift and also is used on the air seal manifolds.

**AP4480 AIR VALVE**

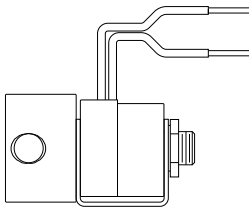

This is a normally closed valve and is activated by switching + voltage. This is the basic valve and is used in several different valve arrangements. This valve is not mounted on a manifold. It is used on older air leveling systems, on some air compressors and is used as a suspension air dump valve for hydraulic leveling systems.

**AP19508 AIR VALVE**

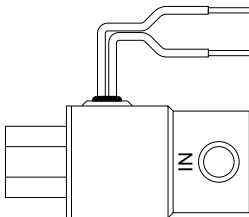

This is a normally open valve and is activated by switching + voltage. This is the basic valve and is used in several different valve arrangements. This valve is used on air compressors.

**AP5868 AIR VALVE**

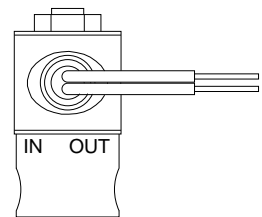

This is a normally closed valve and is activated by switching + voltage. This valve is used on air compressors.

**Fig. 24**

**2-11.2 Hydraulic solenoid valves.** Hydraulic solenoid valves direct the flow of fluid in our leveling systems, room extension systems and other slide mechanisms. There are presently two basic hydraulic solenoid valves. They are simply referred to as the “large” and “small” valves. The main difference between the two valves is the flow rate. The large valve has a bigger seat orifice than the small valve. Large and small valves should never be interchanged. The flow of fluid would be changed which can affect the operation of the system. Both the large and small valves are equipped with a ¼ inch valve release nut for manually opening the valve in the case of an electrical failure. When used with an auxiliary hand pump system, the small valve is equipped with a valve release cam lever to manually open the valve.

Note: As of April 2011, all small and large valves, 12 and 24 volt, for all leveling and room extension systems will be equipped with the valve release cam lever.

Both valves draw about the same amount of current, the large valve using slightly more. Also, due to the design of the valves, the large valve can remain on for a longer period of time without causing damage to the coil of the valve. Both the large and small valves are available with either 12 volt or 24 volt coils.

Except for one valve, the AP3572, all solenoid valves are operated by switching + voltage. This valve is only used with the 400 series paddle switch automatic leveling systems. This system was produced from 1985 until about 1992. The AP3572 valve is operated by switching a ground. This valve has a transistor attached to the body of the valve. One of the valve wires is +12 volts. The other wire is the signal or control wire. This wire controls the transistor on the valve. When a ground signal is supplied to the transistor, the transistor supplies a ground for the coil of the valve. Ground for the valve coil is supplied through the body of the valve. This requires a good ground for the manifold. If the manifold mounting becomes loose or corroded, this can cause a weak ground which will result in damaging the valve transistor. This would cause the valve to not function at all or to remain on constantly whenever +12 volts is supplied to the valve.

Until 2003, the large valves had a back emf diode installed in the valve. Because the necessary protection for the valves is now in the control box, the diode was removed. The small valves never had the back emf diode. Because this diode is still necessary in older systems, all replacement large valves have the diode.

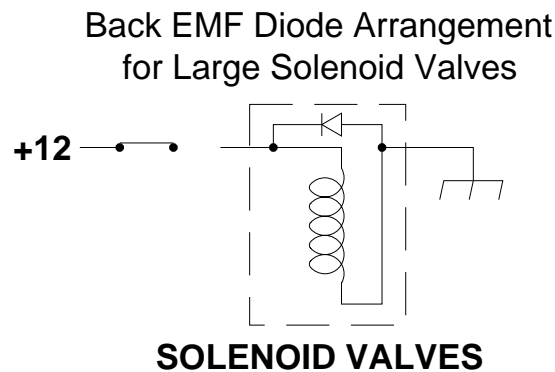

**Fig. 25**

Except for the AP3572 valve and a single wire, hex shaped valve with a groove, the AP5506, the RAP0642 is the replacement valve for all large valves. Some older large valves only had one wire and were internally grounded. An adaptor is available to upgrade to the new valve.

In production at HWH, some small valves had a filter screen around the seat and some did not. It is a good idea to make sure the screen or the band that keeps the screen in place does not remain in the manifold when the existing valve is removed. At the present time, all production and replacement valves are manufactured without the screen.

The following are the different hydraulic solenoid valves:

**AP3572**

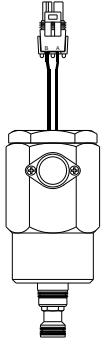

This valve is on used on the 400 series automatic leveling system. This valve must be replaced with a like valve. This valve has no manual release.

**AP5564**

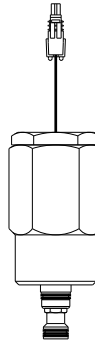

This valve is on used on the 510 series leveling system. This valve has no manual release.

**AP5506**

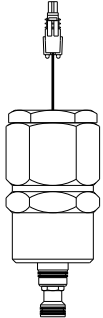

This is the stabilize valve for 510 series leveling systems. This valve must be replaced with a like valve. This valve has no manual release.

See the chart on the next page for a list of all previous and present day small and large valves for replacement information.

**Large 2-1/4" Round Valves**

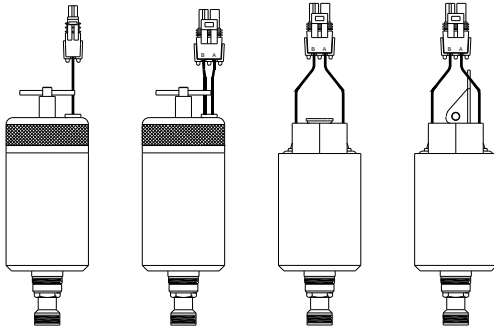

The 2-1/4" round solenoid valve was developed to replace the AP5564 hex valve. The original large round valve had (1) wire and a Tee Handle for a manual valve release. This valve has undergone several changes to evolve into the present day (2) wire round valve with a valve release cam lever for manual operation. Before the cam release lever, valves went from the Tee Handle to a 1/4" valve release nut. The present day 12 volt valve (as of May 2011) replaces all previous large 12 volt valves except the AP3572, the AP5506 and the AP47151, a present day hi flow valve. An adapter wire is needed when replacing older (1) wire valves. The large valves have mainly been used on leveling systems but were also used on early room extension systems. The large valve is also available as a 24 volt valve.

**Small 1-1/2" Round Valves**

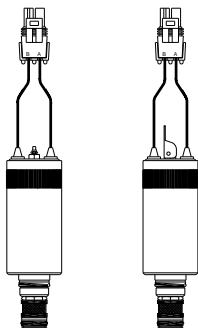

The small round valve was developed in the late 1990's to be used for room extensions. These valves were eventually used in leveling systems with smaller capacity jacks. The small valve has been produced with and without a screen around the seat of the valve. The original valve was equipped with a 1/4" valve release nut for manual operation of the valve. The present day valve (as of April 2011) has no screen and is equipped with a valve release cam lever. The small valve is available as a 12 or 24 volt valve. the present day small valve (12 or 24 volt) replaces all previous small valves (12 or 24 volt) except the AP41040, a hi flow small valve used with step covers.

**Fig. 26**

# VALVE REPLACEMENT CHART

## LARGE 2-1/4" SOLENOID VALVES

ORIGINAL PART #	DESCRIPTION	REPLACEMENT PART #
AP3572	12 VOLT VALVE WITH TRANSISTOR	RAP3572
AP5506	12 VOLT (1) WIRE HEX VALVE – HI FLOW	RAP5506
OBSOLETE AP5564	12 VOLT (1) WIRE HEX VALVE – NEEDS ADAPTOR WIRE	RAP0642
OBSOLETE AP0642	12 VOLT (1 OR 2) WIRE VALVE WITH DIODE AND TEE HANDLE	RAP0642
AP31628	12 VOLT (2) WIRE VALVE WITH RELEASE CAM – NO DIODE	RAP0642
OBSOLETE AP32629	12 VOLT (2) WIRE VALVE WITH 1/4" RELEASE NUT – NO DOIDE	RAP0642
AP36232	24 VOLT (2) WIRE VALVE WITH RELEASE CAM	RAP91883
AP39015	12 VOLT (2) WIRE VALVE WITH RELEASE CAM – WITH DIODE	RAP0642
OBSOLETE AP46254	12 VOLT (2) WIRE VALVE WITH RELEASE CAM	RAP0642
AP47151	12 VOLT (2) WIRE VALVE WITH RELEASE CAM – HI FLOW	RAP92824

## SMALL 1-1/2" SOLENOID VALVES

ORIGINAL PART #	DESCRIPTION	REPLACEMENT PART #
OBSOLETE AP14273	12 VOLT VALVE WITH 1/4" RELEASE NUT – NO SCREEN	RAP90729
OBSOLETE AP24604	12 VOLT VALVE WITH 1/4" RELEASE NUT – WITH SCREEN	RAP90729
OBSOLETE AP36233	24 VOLT VALVE WITH 1/4" RELEASE NUT	RAP91882
AP36234	24 VOLT VALVE WITH RELEASE CAM	RAP91882
AP41040	12 VOLT VALVE WITH RELEASE CAM – HI FLOW	RAP92108
AP42632	12 VOLT VALVE WITH RELEASE CAM – NO SCREEN	RAP90729
OBSOLETE AP46848	12 VOLT VALVE WITH RELEASE CAM – NO SCREEN	RAP90729

**2-11.3 Solenoid valve diagnostics.** All solenoid valves used by HWH, air and hydraulic, are tested the same way for electrical problems. The only exception is the AP3572 hydraulic valve with the transistor. We will discuss that valve a little later in this section. The two main questions that need to be answered before diagnosing the issue are: What is the operating voltage of the valve? Is the valve a normally closed or normally open valve?

To diagnose a valve that seems to be energized all the time you simply unplug the valve. If a normally closed valve remains open allowing fluid or air to flow, the valve is bad. If a normally open valve will not allow fluid or air to flow, the valve is bad. If when unplugged the valve returns to its normally off position, the problem is the controls.

When diagnosing a valve that will not energize, there are several things that can be done. The recommended way to diagnose this type of problem with HWH systems is to check the voltage for the valve. When making this test, the valve must be plugged in and turned on. The leads for the voltmeter must be connected to the power and ground supply for the valve where the valve plugs into the harness. If testing a single wire valve, the ground lead of the meter should be held to the body of the valve. **Do not poke holes in the wires or try to slide the test lead by the connector seal. The water tight integrity of the wire or connector will be damaged.** Use some short test leads to connect the valve to the harness or a testing adaptor is available from HWH for 2-pin Packard Connectors.

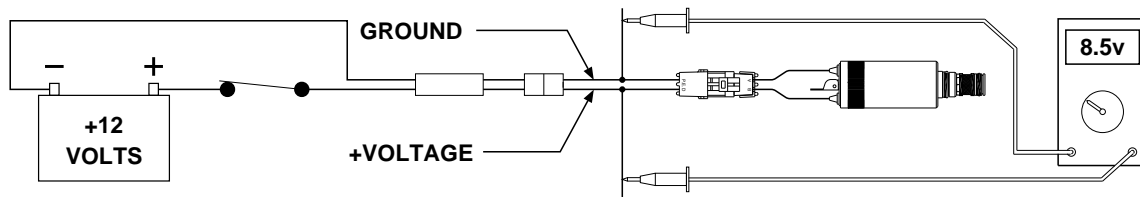

**Fig. 27**

If testing air solenoid valves, the valves should energize if there is a minimum of 8.0 volts at the valve. (12 volt valves) If testing hydraulic solenoid valves, valves with either a 12 volt or 24 volt coil should energize with a minimum of 8.5 volts at the valve. If you have the minimum voltage required, and a valve will not energize, the valve is bad. It is not necessary to check the resistance of the coil.

Two wire valves can also be tested with a simple continuity tester. There should be continuity, very little resistance, between the two wires of the valve. There should be no continuity, an open circuit, between either valve wire and the body of the valve. If the valve passes these tests, the valve should still be tested using the voltage method. The continuity tests will only tell you if the valve is bad, not if the valve will work.

**Diagnosing the AP3572 hydraulic solenoid valve with the transistor.** This valve is only used for the 400 series leveling systems. The control panel for this system was equipped with four paddle switches for manual control of the valves. Treat the valve like a single wire valve. While pushing the appropriate paddle switch to "RETRACT", check the voltage between the + 12 volt side of the valve and the body of the valve. If there is a minimum of 8.5 volts, the valve should operate. If it does not, the valve is bad. If the valve will not close, unplug the valve. If the valve does not close, the valve is bad. If the valve does close, remove the colored wire (not the red wire) from the harness plug. Plug the valve back in. If the valve opens, the transistor is bad and the valve should be replaced. If the valve does not open, the problem is in the controls. A quick check that you can make to see if the transistor is bad is to simply touch the valve. If the valve is scalding hot, the valve is bad. This test will only work if the control panel has been turned on for a few minutes.

**2-12 PUMP MOTORS.** The pump motor is the electrical component that creates the flow of fluid in the hydraulic systems. The motor is attached to the gears of the pump. When the motor turns, the gears of the pump turn. This creates hydraulic flow. The basic parts of the motor are the armature and commutator, the poles and field windings, and the brushes. I don't want to get into a too detailed explanation of how a motor works, so here is the condensed version. When current is applied to the armature and the field windings, it creates two opposing magnetic fields. Like fields repel and unlike fields attract. This is what makes the motor turn. As the armature revolves, the current flow through the armature is reversed every half turn between the brushes and the commutator. This is what keeps the motor turning. As I said, this is a very condensed explanation of how a motor works. There are many good books that will give detailed discussions about magnetism and motors if you are inclined to gain that knowledge. Be prepared for some in-depth thought.

What we will focus on is the fact that what is needed to make the pump motor function is + voltage and ground. Again, without getting into great detail, here are some basic things to remember about the pump motors:

1. When first turned on, there will be a large inrush of current to start the motor turning. This can create a momentary voltage drop on the pump motor circuit.
2. The current draw of the motor will increase as the load on the motor increases. As the hydraulic pressure in the system increases, resistance to the pump gears turning increases. This increases the load on the pump motor.
3. Cable size is very important for proper system operation. Too small a cable gauge (diameter) will cause an unacceptable voltage drop. This can cause erratic system operation or total system failure. Although HWH has used different size (diameter) pump motors in the past, present HWH pumps, except Oildyne pumps, are equipped with either a 3.7" motor or a 4.5" motor. HWH recommends a 2 gauge cable for the 3.7" motors if the cable length is less than 35 feet. Lengths over 35 feet may create an unacceptable voltage drop and need to be a larger gauge (diameter). HWH recommends a 1/0 gauge wire for the 4.5" motors if the cable length is less than 35 feet. Lengths over 35 feet may create an unacceptable voltage drop and need to be a larger gauge (diameter). The recommended fusing for the 3.7" motor is 150 amps. The recommended fusing for 4.5" motor is 200 amps.
4. Grounding of the pump motor is as important as the voltage supply cable. Except for one Fenner-Stone pump motor used in the early 1990s and the small Oildyne pumps, all other pump motors used by HWH are internally grounded. The motor relies on the mounting of the pump for a ground. If the mounting surface for the pump, such as a compartment floor, will not supply an adequate ground, a separate ground cable must be applied to the pump. It is important to remember that the ground for the pump must be at least equal to the size of the cable that supplies + voltage to the motor. Oildyne pumps and other present day pumps are supplied with a ground stud for centrally grounding the system. This stud can be used to attach a grounding cable to.
5. The motor armature is like a coil. As the amount of current flowing through the armature increases and the length of time the current is flowing increases, the temperature of the armature increases. Except for the Oildyne pumps, HWH pump motors have no thermal protection built in. The rule of thumb is the pump motors should not run continuously under full load for more than three minutes without a cooling period.

Although pump motors can be replaced, HWH does not have replacement motors for all different pump models. Contact HWH for pump motor replacement information. Some pumps have a coupler that joins the motor to the pump. This coupler is not supplied with the new motor, make sure to retain the existing coupler when removing the old motor. Be careful to not let the armature come out of the new motor housing. Reinstalling the armature can be difficult.

HWH uses a reversible pump manufactured by Oildyne. This pump has three leads coming from the motor. One lead is a ground. The other two leads determine the direction the motor spins. Power on one lead will turn the motor clockwise. Power on the other lead will turn the motor counter-clockwise.

**2-12.1 Pump motor diagnostics.** Pump motor diagnostics consists of checking the voltage at the motor and sometimes, checking the current draw of the motor with a clamp-on meter. Either test has to be done with the pump relay on, trying to run the pump. I like to use jumper wires to turn the necessary relays on. That way the tests are done without opening valves. This allows the tests to be done with the pump motor under a full load.

**Voltage test.** This test must be done while trying to run the motor. Check the voltage by putting the + meter lead on the motor + voltage stud. Use the pump housing for the ground lead. If you have a 8.0 volts or more, the pump motor should be running. 8 volts is not very good voltage and it should be determined why the voltage is that low but the pump motor should still run. If you have less than 8.0 volts, locate a good ground that is adequate for the motor and recheck. Resistance in the pump mounting could be the issue. Also check the voltage at the pump relay. Make sure the problem of low voltage is not a connection at the motor.

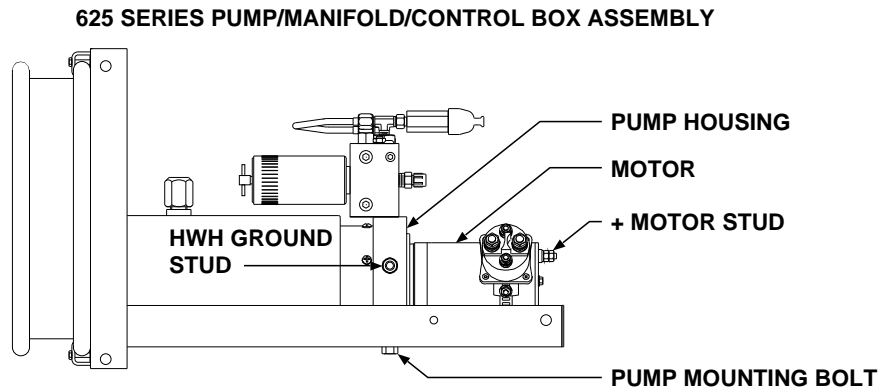

**Fig. 28**

Another problem that may occur is a noisy motor. If the bushings of the motor become corroded, this can cause a grinding noise in the motor. The motor should be replaced. This can be more common with systems that are not used regularly. None of the motors are sealed and water resistant. Moisture can build up in the motor causing oxidation between the shaft and bushing. If the motor is not run occasionally, this can turn into corrosion, causing a noisy motor. The motors have drain holes but this does not totally eliminate the moisture problem. It is a good idea to run the system once in a while.

**2-13 LEVEL SENSING UNITS.** HWH has had two basic sensing units over the years. The original sensing unit was a disk about 4" in diameter. It incorporated an arrangement of mercury switches attached to a plate. The present day sensing unit is an electronic level sensor. *The original mercury style sensing unit is not available anymore but can easily be replaced with the electronic sensing unit.* Both the original and present day sensing units were/are available in different configurations. It is important to get the correct sensing unit when replacing one.

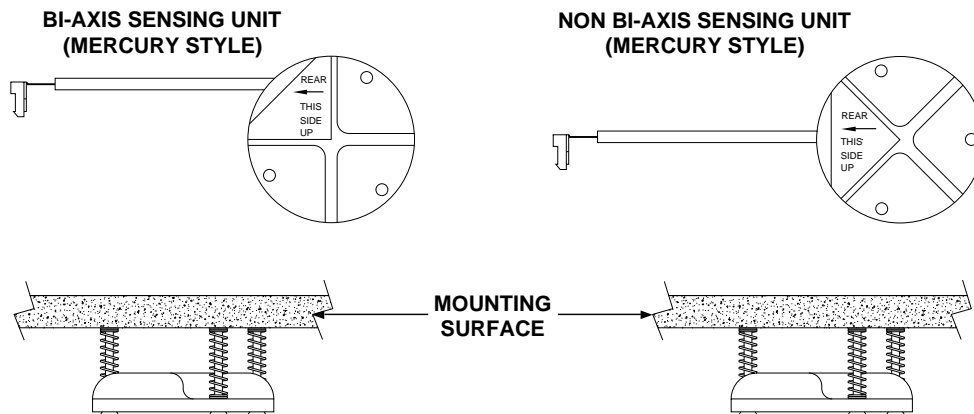

**Fig. 29**



The mercury sensing unit was produced in many configurations. The original ones had four wires with a ground strap attached to the housing of the sensing unit. More recent sensing units had five wires, one of the wires being the ground wire for the sensing unit. As shown in Fig. 29, all sensing units had a sticker that said “This side up” and had an arrow marked “Rear”. It was very important that the sensing unit was mounted properly. There were different sensing units for the old 400 series paddle switch systems. These sensing units had a shielding wire incorporated into the cable. There were also many different cable lengths in each style of sensing unit. The cable for the sensing unit and the sensing unit head were assembled as one piece and were always replaced as one piece.

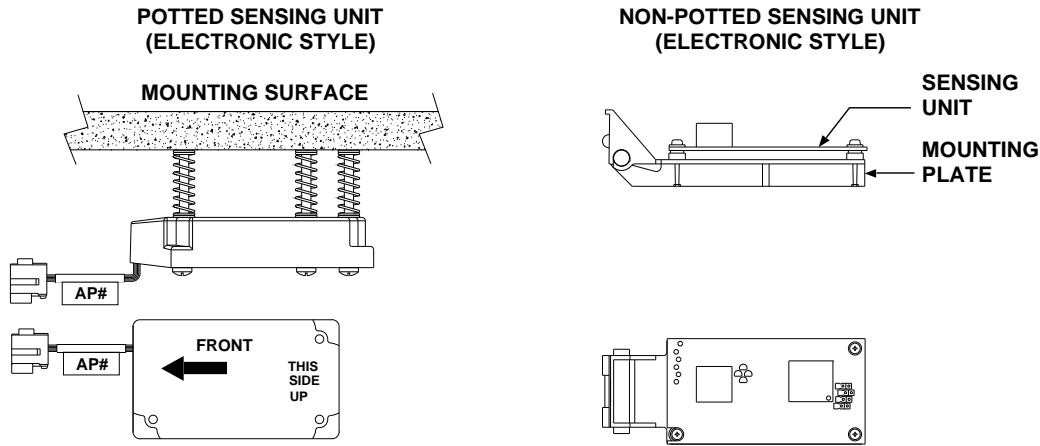

Fig. 30

The electronic sensing unit, like the mercury sensing unit is produced in different configurations, just not as many. The **non-potted electronic sensing unit** is used in most touch panel controlled leveling systems. The sensing unit is located in the control box. Although this eliminates the mounting of a remote sensing unit, it does require that the control box or the power unit control assembly be mounted securely to the vehicle. Bracing needs to be used when necessary to eliminate vibrations or shaking of the power unit or control box. It is also necessary that the equipment housing the sensing unit is mounted as parallel or perpendicular to the frame of the vehicle as possible. The sensing unit then needs to be programmed to determine the front of the vehicle and the type of suspension, air or spring. The non-potted sensing unit can be programmed at HWH or is available as a programmable sensing unit that can be easily programmed in the field. The programmable sensing unit is mainly used for aftermarket installations and repairs.

The **potted electronic sensing unit** is an electronic sensing unit encased in a plastic housing and sealed with epoxy. The potted sensing unit is mounted remotely from the control box, light plate or valve. Like the original sensing units, the potted sensing unit is marked with mounting instructions, “This Side Up” and an arrow marked “Front”. The sensing unit must be mounted per these instructions to function properly. **Please note the original sensing units had the arrow pointing “Rear” and the new potted sensing units have the arrow pointing “Front”.** The potted sensing units have only a short cable as part of the assembly. The cable that connects the sensing unit to the controls is a separate piece of equipment. The length of the cable can vary along with the type of connector needed to attach the cable to the controls. Because the potted sensing unit is always mounted in one direction, it does not have to be programmed for direction. It does however need to be programmed for suspension type and leveling format, either bi-axis or non- bi-axis leveling. The potted sensing unit is not programmable in the field and it is important to get the proper sensing unit for the type of suspension and leveling system the sensing unit is used with.

All leveling systems (at this time) that incorporate a level sensing unit have yellow level indicator lights on the control panel. These lights are controlled by the level sensing unit. Although the mercury style and the electronic sensing units are worlds apart in their design, they both do the same thing the same way. They control the yellow level indicator lights for all systems. For computerized systems, they give the processor the information needed to level the vehicle. The way this is accomplished is by completing a ground circuit on the four level sensor pins. Non bi-axis systems have a level light for each corner of the vehicle, left front, right front, right rear and left rear. Bi-axis systems have a level light for each end or side of the vehicle, front, rear, left side or right side. There is an electrical pin connection for each light. When the vehicle is low on a side, end or corner, the sensing unit completes a ground circuit on the appropriate pin. The only practical difference between the two types of sensing units is the electronic sensing unit is a six wire component and the mercury sensing unit is a four or five wire sensing unit. The sixth wire for the electronic sensing unit is a + voltage wire for the electronic equipment on the sensing unit.

**2-13.1 Level sensing unit adjustment.** All sensing units have to be adjusted after installation or if the sensing unit is removed and replaced. Electronic sensing units installed in control boxes will have to be programmed before adjustment. Although the mercury sensing unit is no longer available, it is possible that you may run into one that needs adjustment.

**The most important thing to understand about sensing units is the accuracy tolerance of the sensing unit.** All HWH sensing units have an accuracy tolerance. Due to the nature of leveling a vehicle, a sensing unit with a tolerance of 0 degrees will not function properly. Because of the movement of the vehicle, the level indicator lights will bounce back and forth as the vehicle approaches a level position. We have discovered over the years a tolerance of  $\frac{1}{2}$  to  $\frac{3}{4}$  of a degree is the best tolerance to obtain a reasonable levelness of the vehicle. On our adjustment sheets we change degrees to inches for our stated tolerance. We use the example of a 36 foot vehicle. When you do the math, the tolerance figures out to be 5.4 inches front to rear and 1 inch side to side. We use the same tolerance for the mercury and electronic sensing units. ***This means if the vehicle is leveling within the tolerance of the sensing unit, DO NOT adjust the sensing unit.*** Make sure the owner of the vehicle understands the level sensor tolerance. For a quick reference we tell people to use a round refrigerator bubble level. If  $\frac{1}{2}$  the bubble is in the bulls eye, the vehicle is level within the tolerance of the sensing unit.

Only the levelness of the vehicle can be adjusted. The tolerance is set and cannot be adjusted. Because a vehicle with an air suspension has less “bounce” while leveling, electronic sensing units for vehicles with an air suspension has a slightly tighter tolerance than the standard sensing unit for vehicles with spring suspensions. The air suspension sensing unit should not be used on vehicles with spring suspensions. The leveling system performance may be diminished.

Before adjusting a sensing unit, it must be determined what level is. Level is level when looking at a leveling instrument. BUT, this is not true when looking at a vehicle, especially a motor home. If the countertop is level, the floor of the vehicle may not be. If the floor is level, the refrigerator door may swing one way or the other. If possible, the owner of the vehicle should be consulted before adjusting the sensing unit. After determining what should be level and the vehicle is leveled to that object, it is a good idea to check several other places on the vehicle to make sure nothing will be to far from level compared to the main leveling point. It is also important to pay attention where the main leveling point is. If that point is in a room extension, the room should be extended with the main point level before adjusting the level sensing unit. Level with the room in may not be level with the room out, and normally the room will be out when the vehicle is leveled and in use. Finally, make sure the vehicle owner/operator knows where you have checked for the levelness of the vehicle. As I said before, not everything in a vehicle may be level to each other. It is important that levelness is checked from the same place every time. ***Limit movement in the vehicle when adjusting any sensing unit.***

Adjusting a mercury switch sensing unit is fairly simple and will be explained in one of the following sheets. The electronic sensing unit is a little more complicated to adjust properly. Pay attention to the “tweaking” instructions when adjusting an electronic sensing unit. It is also important to get the vehicle out of level and level the vehicle with the leveling system according to the yellow level indicators after adjusting the sensing unit. This is when the “tweaking” may take place. The following are the adjustment and tolerance sheets for the various styles of sensing units:

MI9543 Non-electronic sensing unit tolerances & adjustment (mercury style sensing units)

ML47509 Electronic sensing unit tolerances & adjustment-control box mounted

ML47508 Remote mounted “potted” electronic sensing unit tolerances & adjustment

**IMPORTANT: No matter what point of the vehicle is used as the “Level Point”, to check the repeatability of the sensing unit, a level should be placed as close as possible to the mounting area of the sensing unit. The flexibility of the vehicle will cause the levelness of the main “Level Point” to change in different parking areas. It is important to explain this to the vehicle operator.**

**NOTE:** As of Nov. 2010, 2000 series control boxes and all potted electronic sensing units have an adjustment enhancement that allows for a more precise level sensor adjustment. See adjustment sheets ML47509 (control boxes) and ML47508 (potted sensing unit) for detailed use of the adjustment enhancements.

**2-13.2 Sensing unit programming.** The electronic level sensing units that are installed in the control boxes have to be programmed to recognize the front of the vehicle and the type of suspension, spring or air. Sensing units set up for specific applications are programmed at the time of manufacture. This is done with the use of resistors placed where the programming pins would be on a programmable sensing unit. **Control boxes with a pre-programmed sensing unit must be installed in a specific direction.** The program chip on the sensing unit board will have a sticker that says “THIS SIDE UP” and an arrow pointing to “FRONT”. We also refer to the “direction” of the vehicle. No matter what the actual direction the vehicle is pointing, we always refer to the front of the vehicle as “North”. The rear of the vehicle is “South”. The passenger side of the vehicle is “East”. The driver side of the vehicle is “West”.

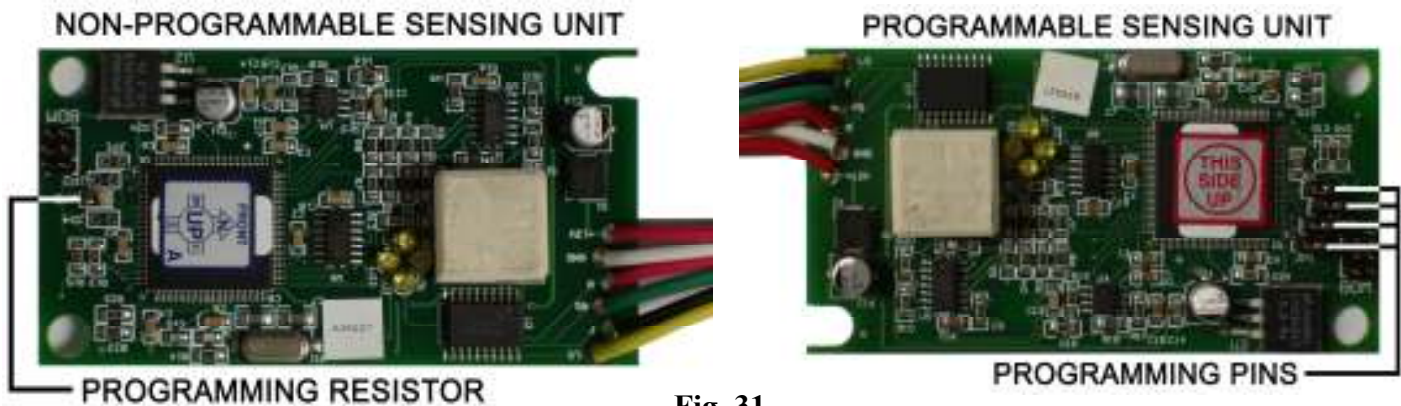

There are four jumpers on the programmable level sensor board which are labeled JP1, JP2, JP3 and JP4. JP1 and JP2 are used for programming direction. JP3 and JP4 are used to program suspension type.

The instruction brochure for programming of the electronic sensing unit is [ML31215](#). The brochure is printed on one sheet, front and back, and contains information about jumper placement for sensing unit direction and for selection of suspension type. Suspension selection is on the second page of the brochure. The instruction sheet has four different views of the sensing unit in relationship with where the front of the vehicle is. Pick the correct orientation of the sensing unit with the front of the vehicle. Move the appropriate jumpers according to the sheet. **Make sure the jumpers that are needed are connecting the correct jumper pins.** If power to the control box is not off and the sensing unit remains plugged in while programming the sensing unit, the new program will not override the existing program until power is removed from the control box. The program chip has to “reboot” like a regular computer to accept the new program.

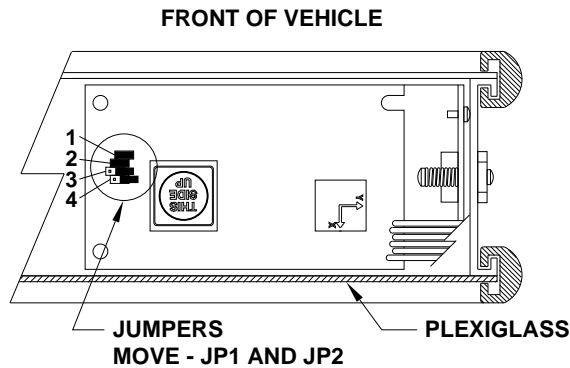

Fig. 32

**Hint:** To use the sheet properly, lay the sheet on a flat surface and rotate the sheet to determine the orientation of the sensing unit to the front of the vehicle.

**Another hint: Program the sensing unit before installing the power unit or control box in the vehicle. Depending on the mounting location of the control box, the rubber gasket that attaches the clear plastic cover to the box can be difficult to install properly. It is critical that the cover and gasket are installed properly to keep water out of the box.**

**2-13.3 Sensing unit diagnostics.** This is the easiest part of our sensing unit discussion. The only difference between diagnosing a mercury style and an electronic style sensing unit is the + voltage supply wire for the electronic sensing units. The potted electronic sensing unit may be a little more difficult to diagnose, but only because of the connectors used. We are developing a test plug for the potted sensing unit and it may even be available as you read this.

Testing for any style level sensing unit can be done with a test light. In fact, testing sensing unit problems is easier with a test light than a meter. Present day systems will either have a five pin connector for mercury sensing units or a six pin connector for electronic sensing units. I usually start my diagnostics at the control box or the control panel, where ever the sensing unit attaches to. For five pin mercury sensing units there are five questions:

1. Is there a ground on the ground supply pin?
2. When you ground the pin for the front level light, does that light and only that light come on?
3. When you ground the pin for the rear level light, does that light and only that light come on?
4. When you ground the pin for the left side level light, does that light and only that light come on?
5. When you ground the pin for the right side level light, does that light and only that light come on?

If the answer to all five questions is “yes”, the problem is the sensing unit.

If the answer to any of the five questions is “no”, there is a problem with the control box or panel.

When making these tests, after checking the ground supply pin, use that pin to test the other four pins.

When testing electronic sensing units of either style, there are six questions to answer. Five of the questions are the same as with the mercury sensing unit.

1. Is there a ground on the ground supply pin?
2. Is there + voltage on the + voltage supply pin?
3. When you ground the pin for the front level light, does that light and only that light come on?
4. When you ground the pin for the rear level light, does that light and only that light come on?
5. When you ground the pin for the left side level light, does that light and only that light come on?
6. When you ground the pin for the right side level light, does that light and only that light come on?

If the answer to all six questions is “yes”, the problem is the sensing unit.

If the answer to any of the six questions is “no”, the problem is the control box or panel.

Check the ground pin against the + voltage pin when making the tests. If your light does not come on, you know there is a problem with the control box or panel. If those two pins are ok, use the ground pin to test the other four pins for the level sensing lights.

**Hint: If testing an electronic sensing unit that is mounted in a control box and you have no diagrams handy, the sensing unit board is labeled with the wire function where the wire attaches to the board. LS is the yellow wire (left side). F is the black wire (front). RS is the green wire (right side). R is one of the red wires (rear). GND is the white wire (ground) and +12V is the last red wire (+ voltage). You can follow the wires to the connector to determine which pin is which.**

There are several other issues that may arise with sensing units that there is really no test for. In most of these cases, you have to make a judgment call. If a sensing unit does not want to adjust, it seems like the sensing unit is too sensitive, you may have to replace the sensing unit. If the complaint is the sensing unit will not stay in adjustment, the problem is more than likely the mounting of the sensing unit or power unit. The sensing unit must be mounted to a solid surface that will not flex or move. Sometimes, a power unit may need a brace to limit movement and vibration. Think about where the sensing unit is mounted. Is it in a compartment? Maybe the sensing unit is bumped when the compartment is loaded or unloaded. Just make sure the sensing unit is mounted solidly and protected from being bumped.

**2-14 ELECTRICAL CONNECTORS AND WIRE TERMINALS.** This section is one of the more important sections of ELECTRICAL COMPONENTS. The reason I say this is that very often connectors are overlooked as the possible weak point of a circuit. The purpose of a connector or terminal is to pass current from one set of wires to another or to pass current from a wire to a component terminal.

The way to view a connection is not to see one connection point but to see each connection point as multiple connections. When two wires are jointed through a connector there is not one connection but instead, there are three. When a wire is attached to a component such as a relay, there is not one connection but there are two connections at that point. The following examples will show you what I mean.

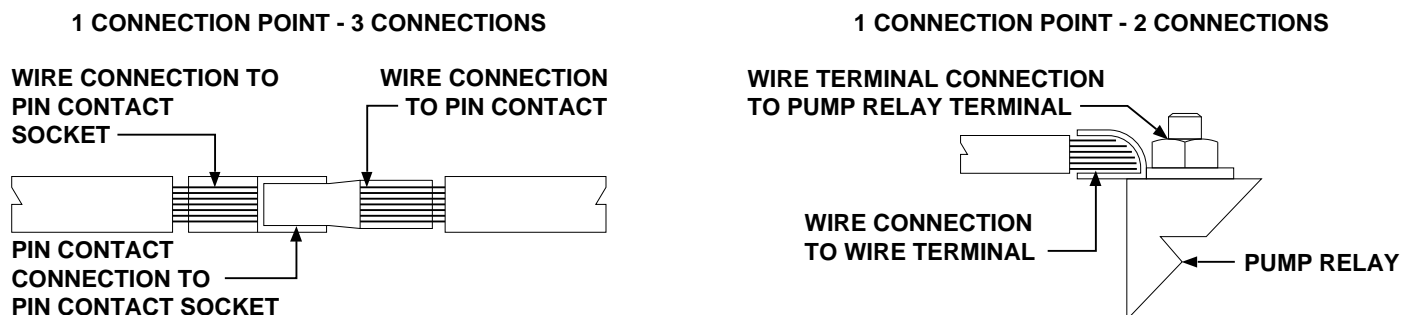

Fig. 33

There are several reasons a connector can be a weak point in a circuit. There may be corrosion or some other type of contaminant on the pins of a connector. Even water tight connectors can be susceptible to this problem. The pins may not fit tight together, causing a loose connection; more resistance in the circuit. A wire may not be properly crimped into the pin, again causing a loose connection. A pin may not be properly inserted into the connector. When the mating connectors are pushed together, the improperly inserted pin may push back causing a weak or loose connection. Often, when a connector or connection is not considered when diagnosing issues, a complete harness or component is replaced. Although the problem is fixed, the actual problem was not addressed. It is even possible the problem may return if the connector that was the issue is not the one that is replaced. The reason the problem is or seems to be fixed is that when the new connector is assembled to the existing connector, good enough contact is made so the problem seems to be gone for the time being. Or if the problem was with the connector that is replaced, the repair ends up being more expensive than it should be. That is a disservice to the customer or the company that may be paying warranty. Connector issues can usually be fixed by taking care of one wire or pin connection if the connector housing is not damaged. It also may kick a warranty claim back if the part tests good when returned under warranty.

**2-14.1 Common types of connectors and terminals used by HWH.** In this section we will discuss the different connectors and terminals we use along with the insertion and removal of connector pins and the assembly of the wire to a connector pin or terminal. This will include discussing the proper tools and techniques used to accomplish this

The type of connector or terminal used is normally determined by the application. Maybe moisture or some other type of contamination is an issue. The number of wires that need to be in one connector may limit the type of connector available. We use single wire connectors and multiple wire connectors including a round Deutsch connector capable of joining up to 31 wires. Current carrying capabilities may be the determining factor. Some connectors are limited to a maximum wire size which limits the current capability of that connector. **It is important when making repairs that correct connector, pin and wire size are maintained. It is also important to use the proper equipment and assembly procedures when repairing or working with connectors.**

There are some important things to understand that are common to most connectors:

1. Connectors have mating halves, usually a male and female connector half. Each of these halves house a contact. These contacts are referred to as the male pin or the female socket, also referred to as a sleeve. For the remainder of this section we will refer to these as the pin or socket. Normally the pin will be housed in the female half of the connector. The socket will be housed in the male half of the connector. *Be careful, this is not a 100% rule.*

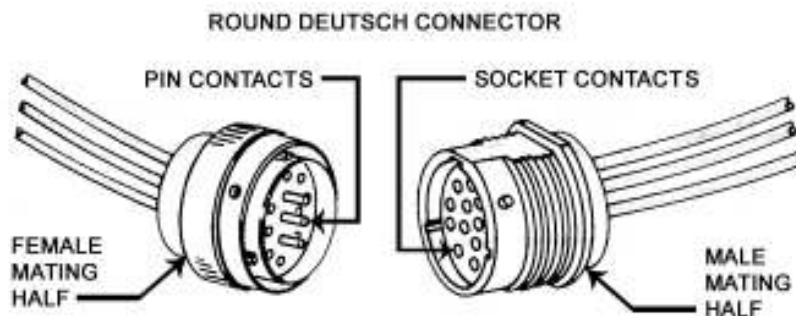

**Fig. 34**

2. The mating halves will have a locking mechanism or latch to keep the connector from accidentally coming apart while in use. *It is important to make sure the locking mechanism is latched when connecting the two mating halves. This insures a good quality, solid connection of the contacts and when applicable, insures a moisture tight seal. It is equally important to understand the locking mechanism and not force the connector apart without unlatching the lock when separating the connectors. Forcing the halves apart would probably ruin at least one half of the connector. See figures on the next page.*

### PACKARD WEATHER TIGHT CONNECTOR

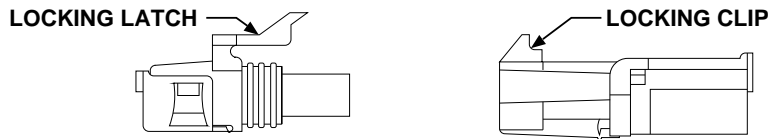

Fig. 35

3. Mating halves will usually have some type of mating guide or pin arrangement that will not allow the two halves to be connected improperly. *It is important to note that some connectors can be plugged in backwards or upside down if forced. Also, where there are multiple connectors of the same type present, it is sometimes not possible to use a special pin arrangement or some type of keying pin. It is always best to mark connectors before removing them or check wiring diagrams for correct wire and connector arrangements.*

### UML CONNECTOR (UNIVERSAL MATE-N-LOCK)

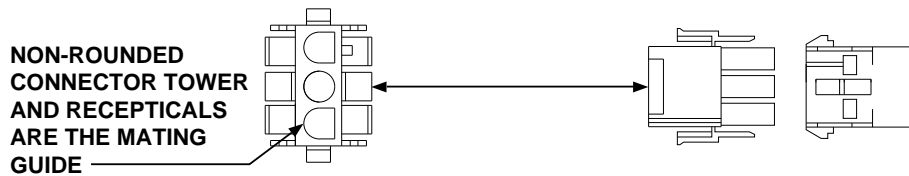

Fig. 36

4. Most connectors have pins and sockets that can be remove and replaced if necessary. This is true of most of our connectors. The only connector we use that does not have replaceable pins and sockets is one of the MTA connectors we use. We use two styles of MTA connectors one has replaceable pins/sockets and the other does not. *Some of the connectors we use need a special tool for pin removal. It is important to use the correct tool to eliminate damage to the pin or socket. There are also special tools for crimping the wires to the contacts. Sometimes the special tool is the only tool that will do a proper crimp.*

### PACKARD CONNECTOR CRIMPING TOOL

### PACKARD PIN/SOCKET REMOVAL TOOL

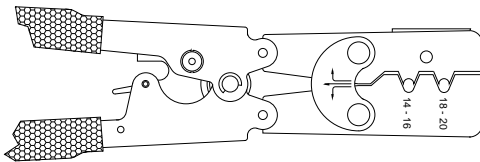

Fig. 37

5. The contact pins and sockets will have some type of latching mechanism to make sure the contact will not push or pull out of the connector. *If the contact is not seated properly into the connector, the contact can be pushed out when the mating halves are assembled or could be pulled out inadvertently if the wire is pulled on. This can create an open or weak connection. Even worse, this very often will be an intermittent problem. It is a good idea to pull gently on the wire after inserting the contact into the connector. This will insure the wire is crimped properly and that the contact is latched in the connector.*

### DEUTSCH CONNECTOR

### UML CONNECTOR

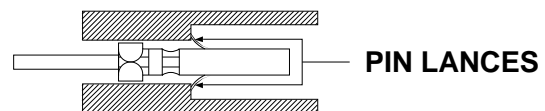
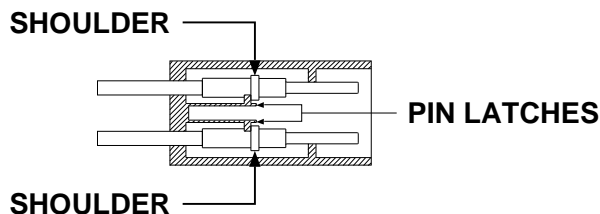

Fig. 38

6. Multiple pin connectors will have pin locations numbered or labeled. Connectors may also have a locating tab. This tab indicates where pin 1 is. This labeling identifies the wire location in the connector for assembly or repair. This information is available on harness drawings, system schematics and wiring diagrams in repair manuals or many operators' manuals. *It is important that correct wire location is maintained. Improper system operation or damage to components can occur if correct wire location is not maintained. Mark all wire locations before removal. Refer to drawings when necessary, do not "guess" or work from memory.*

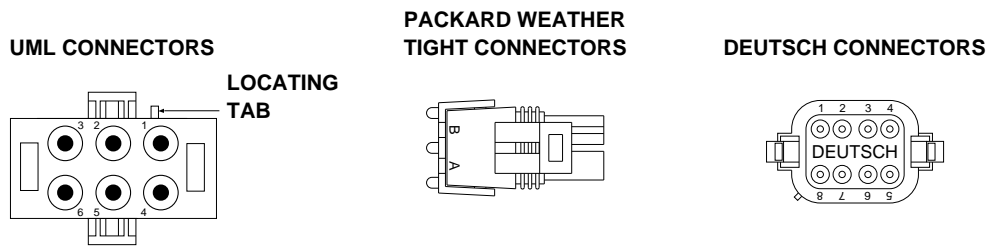

Fig. 39

The following are different types of connectors used by HWH:

**2-14.1.1 Deutsch connectors.** The Deutsch connector is a water tight connector. The connector has a seal where the wires enter the connector and another seal for the two mating halves. We refer to the halves as the plug and the receiver. The Deutsch connectors are available in several different shapes with various wire size and contact capabilities. The Deutsch connectors we use at this time, all use the same pins or sockets. There is a pin or socket for 12 gauge wires, a pin or socket for 14 and 16 gauge wires and a pin or socket for 18 and 20 gauge wires. The pins and sockets have a latching shoulder and the mating halves have latching fingers to hold the contacts in place. The mating halves of the connector have keys and keyways of different sizes so the connector cannot be plugged in incorrectly. The mating halves also have a latching mechanism to keep the connector from coming apart. There is a key pin available so like connectors cannot be plugged in to the wrong mating half. There is also a cavity seal that must be installed in any wire seal holes that are not used so the water tight integrity of the connector is maintained.

**Round Deutsch connector.** The round Deutsch connector has a capability of 31 wires. The wire size can vary from 20 gauge to 14 gauge wire. The mating halves have keys and keyways to assure proper connection. One mating half has a locking ring to lock the mating halves together. The locking ring also pulls the connector together as it is turned. This Deutsch connector requires a special tool for the removal of the wires and pins. The numbering for wire placement with this connector is a little different. The center wire is number 1 and subsequent numbers work out from the center wire in a circular pattern.

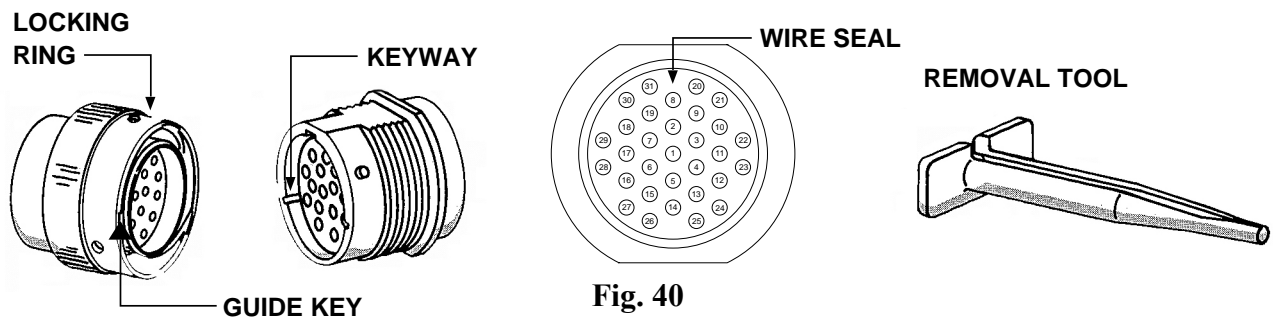

Fig. 40

**Wire and pin removal for the round Deutsch connector** is accomplished with a special tool. This tool must be used so the connector housing is not damaged. The tool has a slot for the wire to lay in. Then the tool is slid along the wire through the wire seal until you feel the tool bottom out. This will spread the latching fingers so the pin can be removed. **Be careful to not damage the wire seal when inserting the removal tool.** Gently pull the wire and tool out together. **Do not force it.** If the wire will not come out easily, reinsert the tool and try it again.



**Square, rectangular and triangular Deutsch connectors.** These Deutsch connectors come in various wire number or size capacities and also in different colors. We use 4, 6, 8 and 12 pin connectors. The triangular connector is a 3 wire connector. We also use these connectors in gray, green, black and brown. The different color connectors have different keys and keyways so that one color cannot be plugged into a different color. **It is important to know that the early brown and green 12 pin connectors could be plugged in upside down if pushed hard enough. The keying has been changed for these connectors to fix that problem. An older male connector can be used with the new receivers but the new male connector will not plug into an old style receiver. Make sure all plugs are positioned properly before plugging them in. Check wiring diagrams if necessary.** One size connector is used for 14 to 20 gauge wires. A larger connector is needed for 12 gauge wires. The contacts for these connectors are locked into the connector with a latching finger for each pin. After all wires are inserted into the connector, a wedge is pushed into the connector to keep the latching fingers in place. The mating halves also have a latching mechanism to keep the connectors from coming apart. The 4 pin, 6 pin and triangular connectors have a single latch. The 8 and 12 pin connectors have 2 latches. These latches will be on opposing sides. Simply depress the latch (or latches) on the plug side and pull the connectors apart. The connectors are labeled on the wire insertion end of the connector. The square and rectangular connectors are numbered. The triangular connector uses the letters A, B and C.



**Fig. 41**

**Wire and pin removal for square, rectangular and triangular Deutsch connectors** does not necessarily need a special tool although a removal tool is available. A small pocket screwdriver with a flat blade of about 1/8 inch wide will work just fine for the plug half of the connector. For the receiver side a small screwdriver and a small needle nose plier will work. First, the wedge must be removed. Use the screwdriver to pop the wedge out of the plug or use the pliers to pull the wedge out of the receiver. After the wedge is removed, use the small screwdriver to hold the latching finger away from the pin. While holding the latching finger, gently pull the wire out of the connector.

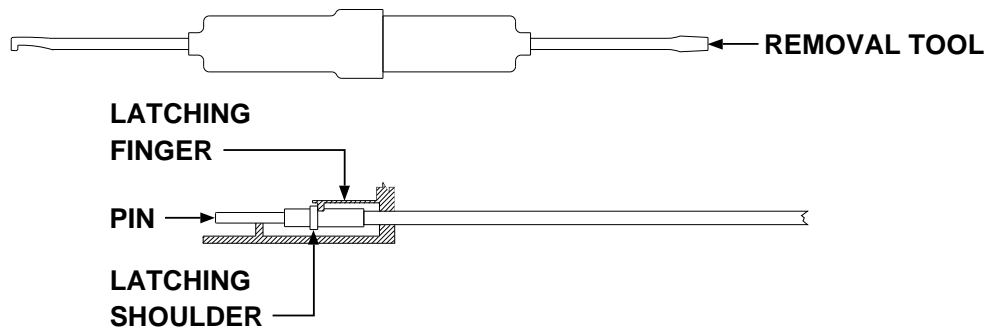

**Fig. 42**

**Wire and pin assembly for Deutsch connectors.** Crimping of wires into the contacts for the Deutsch connectors is the same for all Deutsch connectors used by HWH at this time. We use three different sizes of pins and sockets. One size for 18 and 20 gauge wires, one size for 14 and 16 gauge wires and one size for 12 gauge wires. The pins and sockets for the 14 and 16 gauge wires have a green stripe around the wire receptacle. The size difference for the 12 gauge pins and sockets is obvious.

It requires a special tool to perform the wire crimp for the Deutsch pins and sockets. The tool has several adjustments that must be made before crimping a wire into a contact. There is a wire size selector and a contact depth adjustment screw.

The following is the proper procedure for crimping Deutsch connector contacts:

1. Strip ¼ inch of insulation from the wire.
2. Lift and turn the wire size selector to the appropriate wire size.
3. Select the correct pin or socket for the gauge of wire used.
4. Insert the contact into the crimping tool.
5. The end of the contact should be flush with the crimping tool cover. If adjustment is needed, loosen the lock nut for the contact depth adjustment screw and turn the screw until the contact is at the proper depth. Tighten the lock nut.
6. Insert the wire into the contact and pull the crimping tool handles together until they release.
7. Remove the wire and contact from the tool. Make sure all wire strands are in the contact and gently try to pull the wire from the contact to check the crimp.

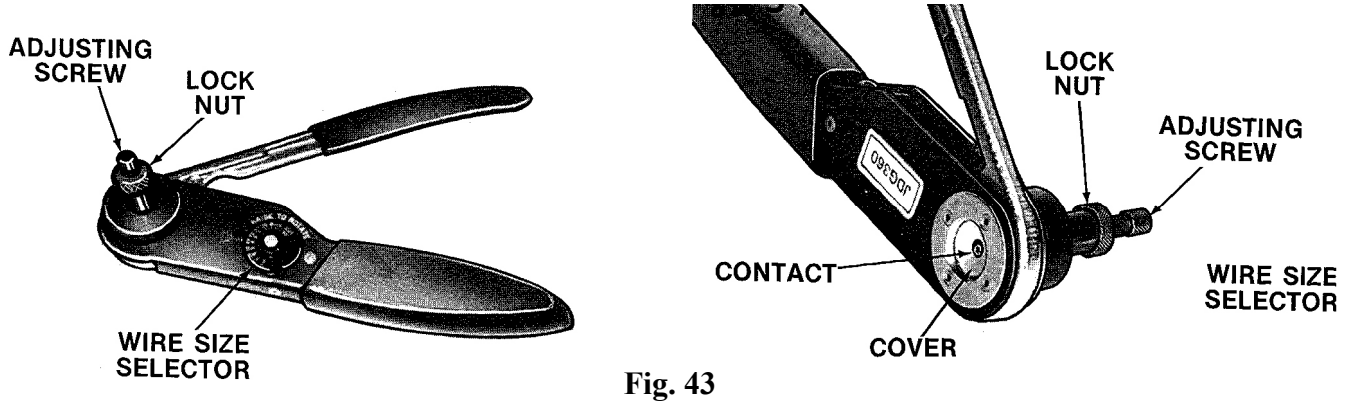

Fig. 43

**Contact and connector assembly for Deutsch connectors** is fairly simple. The wire and contact assembly just pushes into the connector through the wire seal. **Be careful to not damage the wire seal while inserting the wires into the connector. Refer to drawings to make sure the wires are in the correct position in the connector.** To install cavity seals or key pins, simply push the cavity seal or key pin through the wire seal in the correct position. When all contacts, cavity seals and key pins are installed, push the wedge in place. **Make sure all seals are in place and gently pull on the wires to make sure they are locked in place by the wedge.**

**2-14.1.2 Packard Weather Pack Connectors.** We simply refer to these connectors as Packard connectors. Packard connectors are water resistant and are available with different number of wire capacities and in different colors. We use single pin, 2 pin, 3 pin and 4 pin connectors. The 4 pin connectors are available in a flat or square pin arrangement. The 2, 3 and 4 pin connectors are labeled with letters for wire placement, A, B, C or D. Most of the connectors we use have been black, but several years ago we started using gray colored Packard connectors for jack down warning switches. We also use a 3 pin red connector on Hall Effect switches. The different colored connectors are keyed so they cannot be plugged into each other. **We do not use key pins with the Packard connectors so it is important to mark connection and refer to diagrams when disconnecting and reassembling components with the same colored connectors.** Packard connectors have a latching mechanism to hold the mating halves together. You just lift the latch over the locking clip and pull the connectors apart. The contacts have locking lances to keep the contacts in the housing.

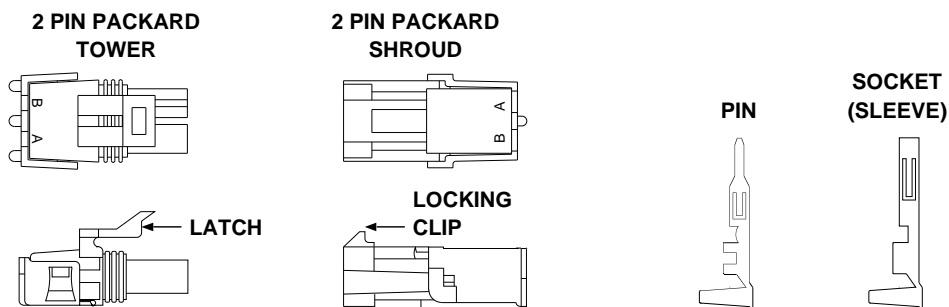

Fig. 44

**Wire and contact removal for Packard connectors** is accomplished with a special tool. Connectors with similar contacts use a like tool but the diameter of the contacts is slightly different. Using the wrong tool may not work and could cause damage to a contact or housing. When the tube of the tool is slid over the contact, the tube compresses the locking lances allowing the contact and wire to be removed from the housing. To remove the wire and contact, first the wire cover protector must be opened. There is a small locking tab on each side of the cover. The sides of the cover must be lifted over the tabs. Gently push and hold the wire and contact assembly into the housing. Slide the removal tool over the contact until it bottoms out. Hold the tool tight against the housing and pull the wire assembly from the housing.

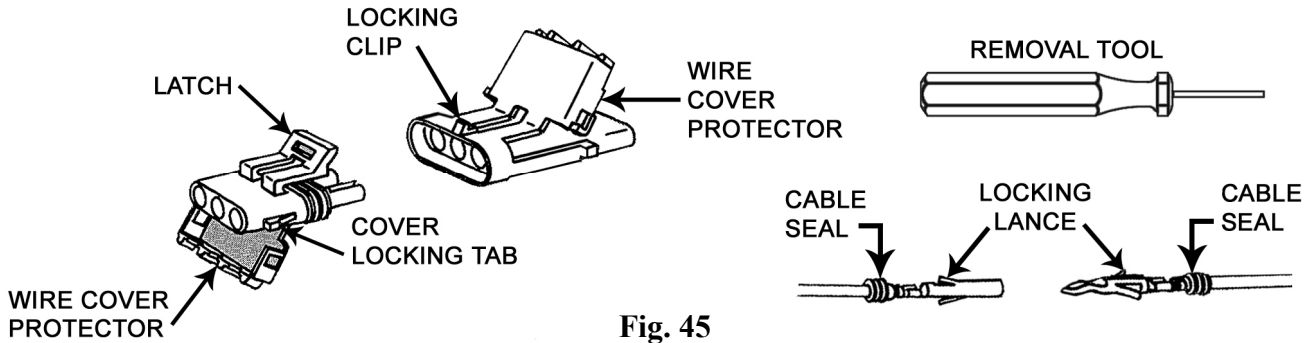

Fig. 45

**Wire and contact assembly for Packard connectors** can be done with a special crimping tool that is available or with a standard terminal applicator designed for crimping Packard contacts. The Packard contacts and wires are assembled with two crimps. One crimp is for the bare wire connection the second crimp is for the wire seal. The special tool does both crimps at the same time. A standard terminal applicator requires making two separate crimps. The special tool is available from HWH. There are different cable seals for different sizes of wire:

Green---18 to 20 gauge wire

Gray----14 to 16 gauge wire

Blue-----10 to 12 gauge wire

The following are the steps for assembling the wire to the Packard contact using a **standard terminal applicator**:

1. Select the proper size seal and slide the seal onto the wire before stripping the insulation. This helps prevent the wire strands from being separated.
2. Strip ¼ inch of insulation from the wire.
3. Position the wire crimp barrel in the crimping tool and close the handles just enough to hold the contact in place. Make sure the crimp wings are centered.
4. Insert the bare wire into the wire crimp barrel of the contact and squeeze the handles together. Remove the contact from the crimp tool and gently try to pull the wire from the contact to check the crimp.
5. Reposition the contact in the crimp tool with the seal crimp wings centered in the crimp tool. Make sure the small part of the wire seal is positioned in the seal crimp wings and pull the handles together. Do not try to pull the seal from the crimp, just make a visual inspection to make sure the seal is crimped to the contact.

Using the **special Packard crimp tool** is the same basic procedure as above except the bare wire and wire seal need to be positioned at the same time because the tool makes both crimps at once. When using the special tool, pull the handles together until they release. This assures a proper crimp and releases the contact.



Fig. 46

### STANDARD TERMINAL APPLICATOR

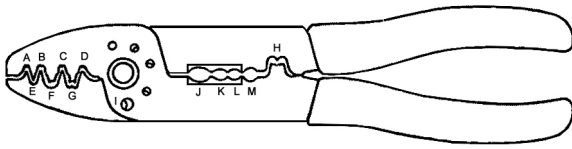

### SPECIAL PACKARD CRIMPING TOOL

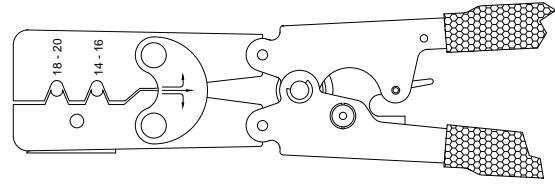

Fig. 47

**Contact and connector assembly for Packard connectors.** The wire and contact assembly just pushes into the housing. The wire cover protector must be open to install the wires. Hold the wire directly behind the wire seal and push the wire/contact assembly into the housing. You will feel a light snap as the locking lances catch on the housing. Push the cover protector closed until the cover snaps over the locking tabs. Give the wire a light tug to assure the wire assembly is securely in place. Check that the wires are in the correct slots before reconnecting the plugs.

**2-14.1.3 UML (Universal Mate-N-Lock) connectors.** These connectors are not weather tight and should not be used where water or moisture is a concern. We use only one style of UML with several different wire number capacities ranging from 2 pins to 15 pins. The mating halves have an arrangement of D shaped towers and receivers. This assures the plugs will be connected correctly. The mating halves also have a latch mechanism to make sure the connectors will not come apart inadvertently. The contacts have locking lances to keep the contacts from coming out of the connectors. *It is important to note the UML contacts and the Packard contacts are very similar in appearance. The UML contacts are slightly smaller. These contacts are not interchangeable. They use different crimping and removal tools.* The pin contact is usually used with the receiver half of the connector and the socket is used with the tower half. We do not use key pins but sometimes when necessary, we reverse the placement of the pins and sockets to assure that different UML connectors with the same number of wires are not plugged in together. The connectors are numbered on the wire insertion side for wire placement. There is a locating tab to find location of pin 1. There is a special removal tool for the UML contacts. This tool should be used to eliminate the chance of damaged contacts or housings. There are two crimps for the UML contacts, a bare wire crimp and an insulation crimp. This can be accomplished with a standard crimp tool. The two crimps are done individually with the standard crimp tool. There is also a special crimping tool available from HWH that performs both crimps at the same time. The special tool is fairly expensive but does a much nicer job than the standard crimp tool.

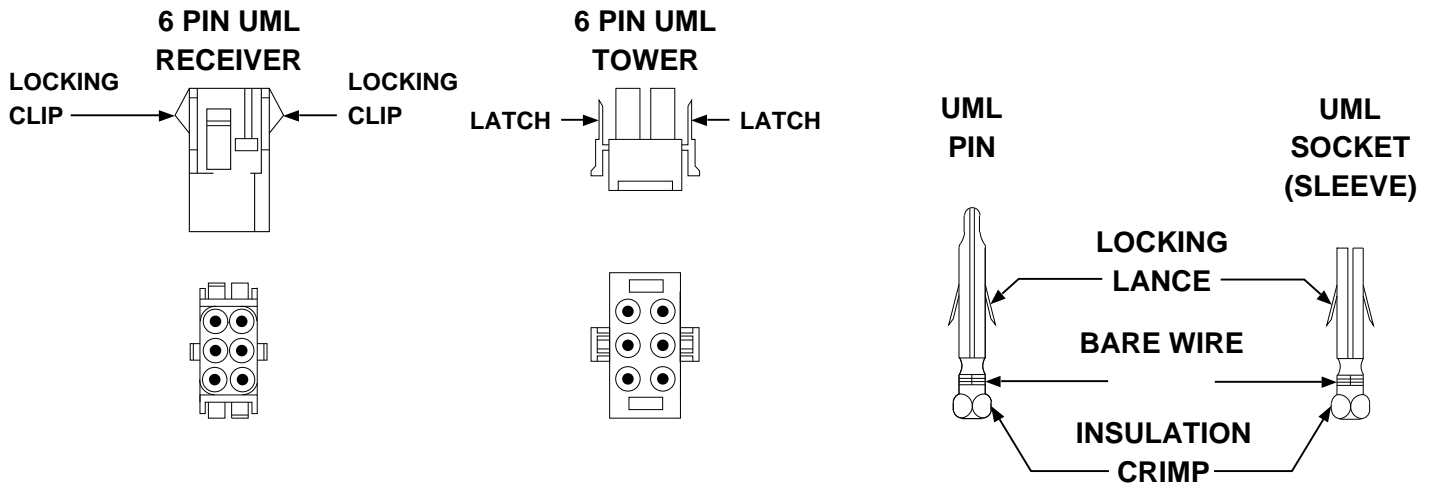
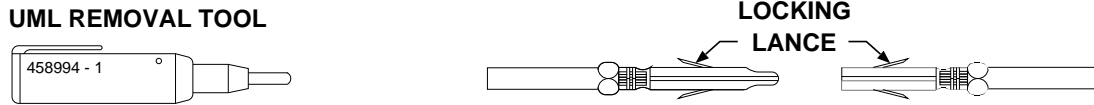

Fig. 48

**Wire and contact removal for UML connectors.** The locking lances on the contacts must be compressed to remove the wire and contact from the connector. The removal tool for the UML contacts is a plunger style tool. Slide the tube of the removal tool over the contact until the tube bottoms out on the connector. Push on the tool. This will pop the wire out of the connector. If the wire does not pop out, try pushing the wire farther into the connector while sliding the removal tool onto the contact. Then push on the tool. The wire and contact should push out of the connector.



**Fig. 49**

**Wire and contact assembly for UML connectors.** A standard style crimping tool is available from HWH to make the UML wire and insulation crimps. This is a reasonably priced tool. Terminal applicators from other sources to do the UML crimps are available also. HWH can supply the special crimp tool that performs both crimps at once but this is a very expensive tool and is not really necessary to have. The crimp tool from HWH for the UML connectors is adequate and will be the only crimp tool discussed in this section. HWH uses contacts that will accommodate 12, 14, 16 or 18 gauge wire. Contacts for smaller gauge wires are available.

The following steps are for making the two crimps to apply the wire to the UML contacts:

1. Strip ¼ inch of insulation from the wire.
2. Choose the appropriate wire crimp position on the tool.
3. Position the wire crimp barrel in the crimping tool and close the handles just enough to hold the contact in place. Make sure the crimp wings are centered.
4. Insert the bare wire into the wire crimp barrel of the contact and squeeze the handles together. Remove the contact from the crimp tool and gently try to pull the wire from the contact to check the crimp.
5. Reposition the contact in the crimp tool with the insulation crimp wings centered in the crimp marked “INS”. Pull the handles of the tool together.
6. Remove the wire and contact assembly from the tool and visually inspect both crimps.

**AMP UML CRIMPTOOL**

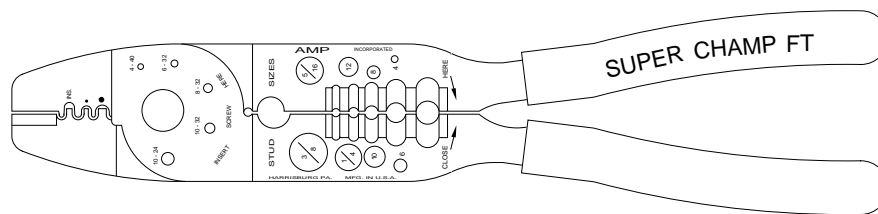

**INSULATION CRIMP BEFORE CRIMPING**

**BARE WIRE CRIMP DONE**

**BARE WIRE CRIMP AND INSULATION CRIMP DONE**

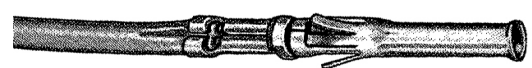

**Fig. 50**

**Contact and connector assembly for UML connectors.** The wire and contact assembly just pushes into the housing. Hold the wire directly behind the wire insulation crimp and push the wire/contact assembly into the housing. You will feel a light snap as the locking lances catch on the housing. Give the wire a light tug to assure the wire assembly is securely in place. Check that the wires are in the correct slots before reconnecting the plugs.

**2-14.1.4 MTA (Mass Termination Assembly) connectors.** We use two types of MTA connectors; a self-stripping connector and a crimp style connector. These are not weather tight connectors and should only be used where water or moisture is not a concern. MTA connectors can be plugged in backwards relatively easy and although a keying pin can be used to assure the connector is plugged in properly, not all MTA connectors will use a key pin. It is also easy to plug in an MTA connector off one or more pins in either direction when a key pin is not used. It is important to use connection diagrams and make a close visual inspection of the connection to prevent connection problems.

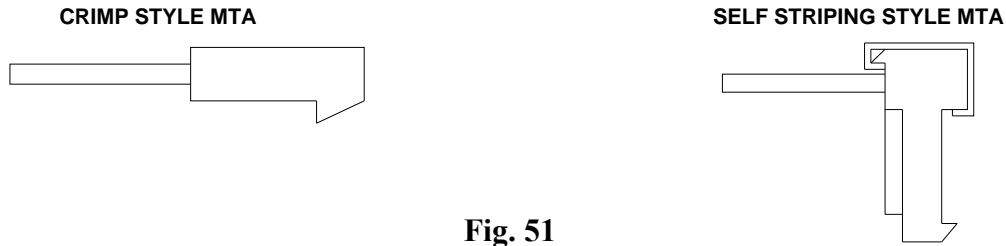

**Fig. 51**

MTA connectors are available as two mating halves, the plug and the receiver but the MTA connectors are not normally used this way. The MTA plug is normally used to attach a harness or a sensing unit to a control box or control panel pin header that is soldered to a pc board. MTA connectors have a locking mechanism to keep the plug from coming loose. When the connector attaches to a pin header, the lock is a friction style latch. If the MTA plug is used with a receiver, there is a latch that has to be pushed down to separate the two mating halves. *When separating the two mating halves or removing an MTA connector from a pc board header, do not pull on the wires.*

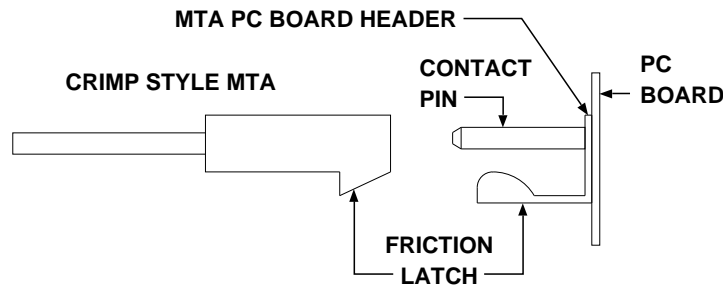

**Fig. 52**

**Wire or contact removal from MTA connectors.**

**Self-stripping style MTA connectors.** The self-stripping MTA connector has an insulating cover that snaps over the wire insertion area. This cover must be removed first. When the wire is pushed into the MTA connector, it is pushed by two small latches that hold the wire into the connector. To remove the wire, you must pull the wire by these two latches. It is best to try to “roll” the wire out of the connector. Do not jerk the wire from the connector, this may cause the contact to be pulled from the connector. If the original wire is to be reinserted into the connector, approximately 3/8 of an inch of wire should be removed from the wire first.

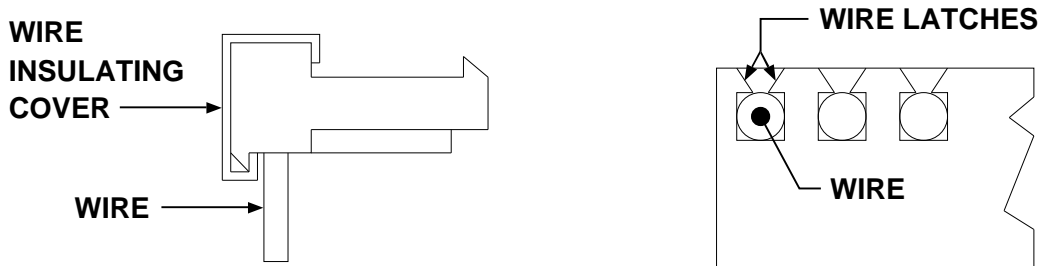

**Fig. 53**

**Crimp style MTA connectors.** The contact for the crimp style MTA connector has a locking lance to latch the contact into the connector housing. Use a small .050” blade screwdriver to depress the locking lance then gently pull the wire/contact assembly from the housing. If reinserting the original contact back into the housing, use the screwdriver to lift the locking lance slightly. This will help the lance to catch on the housing when reinserted.

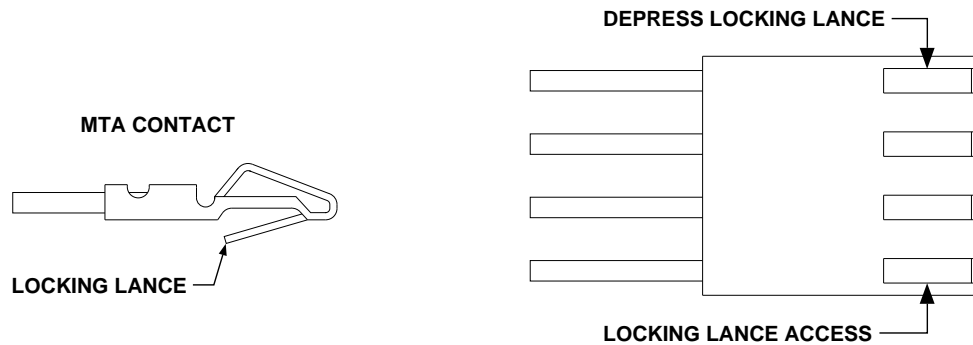
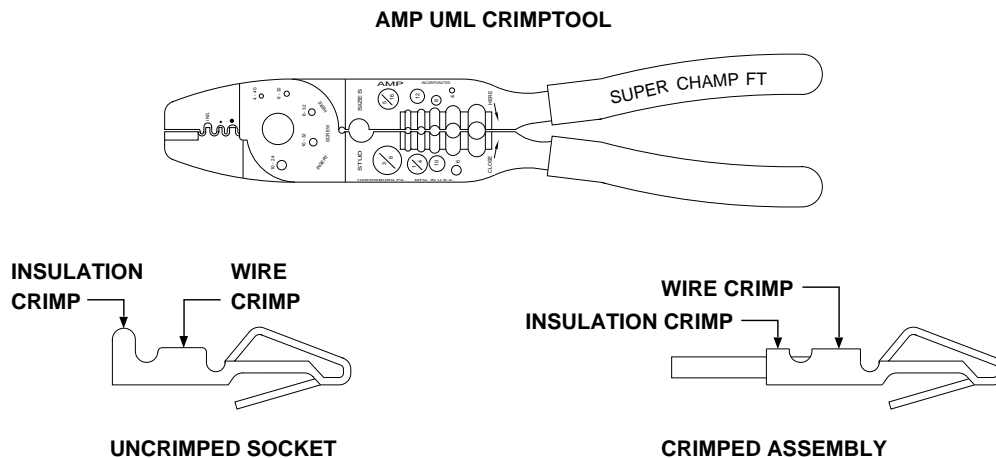

**Fig. 54**

**Wire and contact assembly for the crimp style MTA connector.** The MTA contact has two crimps; one for the bare wire and an insulation crimp. The same crimp tool that HWH supplies for UML connectors is used to crimp the wire to the MTA contact. The wire range for these contacts is 18 to 24 gauge.

The following steps are for making the two crimps to apply the wire to the MTA contacts:

1. Strip 1/8 inch of insulation from the wire.
2. Choose the appropriate wire crimp position on the tool. The crimp with the orange dot will do 12 and 14 gauge wire.
3. Position the wire crimp barrel in the crimping tool and close the handles just enough to hold the contact in place. Make sure the crimp wings are centered.
4. Insert the bare wire into the wire crimp barrel of the contact and squeeze the handles together. Remove the contact from the crimp tool and gently try to pull the wire from the contact to check the crimp.
5. Reposition the contact in the crimp tool with the insulation crimp wings centered in the crimp marked “INS”. Pull the handles of the tool together.
6. Remove the wire and contact assembly from the tool and visually inspect both crimps.



**Fig. 55**

**Wire/contact and connector assembly for MTA connectors.**

**Self-stripping style MTA connectors.** The wire pushes into the connector at a 90 degree angle and is held in place with a retaining latch. When the wire is pushed in, a slot in the contact cuts through the wire insulation to connect with the wire strands. The end of the wire should be cut as straight as possible. The insulation should not be stripped from the wire.

There are several hand tools available to perform this job. The MTA wire insertion T-handle is an inexpensive tool that is used to insert the wires. The end of the tool has teeth that fit into the connector and connector contacts. This tool will only insert one wire at a time. It is best to have a solid surface to rest the connector against while pushing the wire into the connector. Lay a wire in the appropriate slot of the connector and use the T-handle to push the wire into the connector. Push the T-handle as far as it will go. The other tool available is fairly expensive but is a good tool to have if it is necessary to insert a number of wires into MTA connectors. This is a pistol grip tool that will advance the connector to the next slot each time the trigger is pulled. After the connector is inserted into the tool, the wire is inserted into a slot in the tool until the wire bottoms out. Pulling the trigger will push the wire into the connector to the proper depth and advance the connector to the next slot. If a wire is not needed in the next slot, simply pull the trigger to advance the connector. Check wiring diagrams to make sure the wires are in the proper slots.

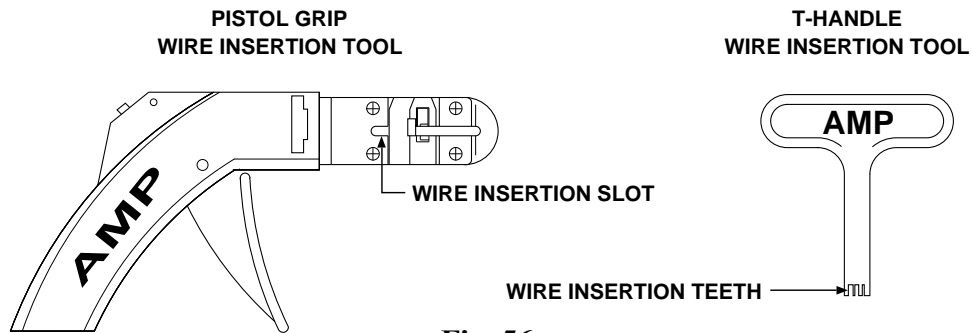

Fig. 56

**Crimp style MTA connectors.** The wire and contact assembly simply pushes into the housing. It will only push in one way. Push the assembly into the connector until you feel the locking lance “click” into place. Gently pull on the wire assembly to make sure it is locked in place. Check wiring diagrams to make sure the wires are in the proper slots.

**2-14.1.5 EJS connectors (Econoseal J series by AMP).** This is a weather tight connector. It has two mating halves, the plug and the receptacle. The plug has the pin contacts and the receptacle has the socket contacts. We use a 6 pin and a 12 pin connector in this style. This style connector is used on the main harness connection along with the level sensing unit connection to the 210/225 joystick valve. It is also used to connect the potted electronic level sensing unit to a harness. The mating halves are keyed and cannot be plugged in backwards. The mating halves have a locking mechanism to keep the halves together. The latch must be depressed to separate the mating halves. The pin and socket contacts are held in the housings with a spring type latch and wedge. The connectors are a two crimp connector. One crimp for the bare wire, the second crimp is for the wire seal. *It is important to note there are no markings or tabs to indicate correct wire positions on the EJS connectors. You must use wiring diagrams and orientate the wires in the connectors as shown in diagrams.*

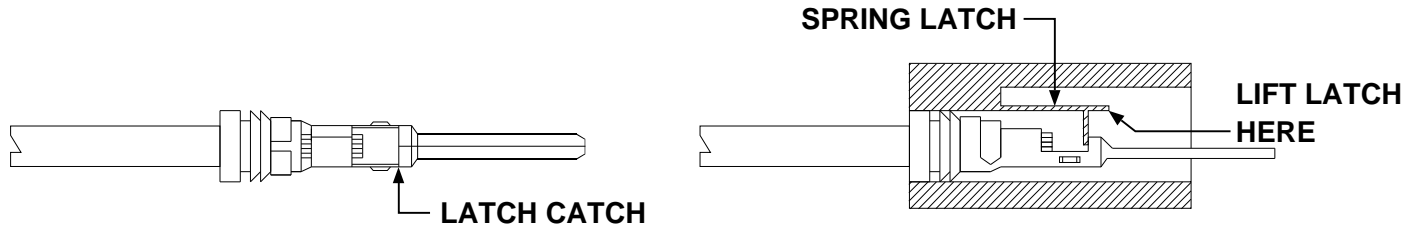

Fig. 57



**Wire and contact removal from EJS connectors.** The contact removal from the EJS connectors can be accomplished with an electronic screwdriver with a .050 blade. First, remove the wedge from the connector. After the wedge is removed, use the screwdriver to lift the spring latch while gently pulling the wire and contact assembly from the housing. The latches are small and can be hard to see. **Do not force the assembly out. This could ruin the assembly and the housing.**

**TOP AND SIDE VIEW OF WIRE AND PIN ASSEMBLY**



**Fig. 58**

**Wire and contact assembly for EJS connectors.** A standard style crimping tool is available from HWH to make the EJS wire and wire seal crimps. This is the same tool used for UML and MTA crimp style connectors.

The following steps are for making the two crimps to apply the wire to the EJS contacts:

1. Slide the wire seal onto the un-stripped wire with the small end of the seal towards the end of the wire.
2. Strip 1/8 inch of insulation from the wire.
3. Choose the appropriate wire crimp position on the tool.
4. Position the wire crimp barrel in the crimping tool and close the handles just enough to hold the contact in place. Make sure the crimp wings are centered.
5. Insert the bare wire into the wire crimp barrel of the contact and squeeze the handles together. Remove the contact from the crimp tool and gently try to pull the wire from the contact to check the crimp.
6. Position the small end of the wire seal onto the wire seal crimp wings.
7. Reposition the contact in the crimp tool with the wire seal crimp wings centered in the crimp marked "INS". Pull the handles of the tool together.
8. Remove the wire and contact assembly from the tool and visually inspect both crimps. Do not try to pull the wire seal from the crimp.

**AMP UML CRIMPTOOL**

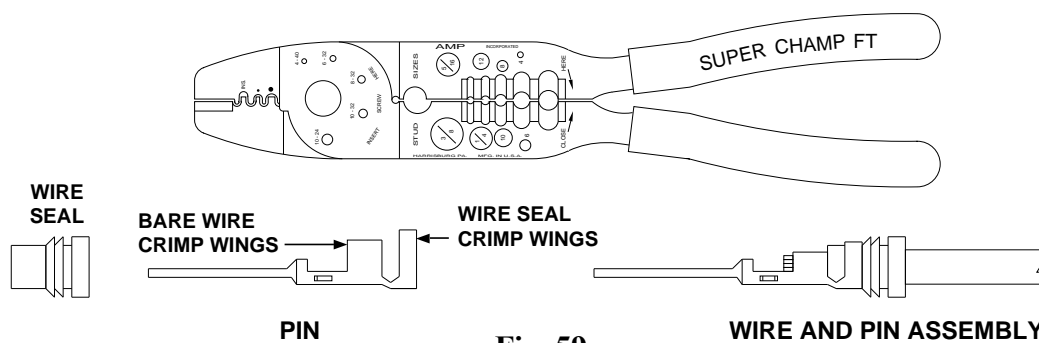

**Fig. 59**

**Contact and connector assembly for EJS connectors.** The pin contact is used with the plug and the socket contact is used with the receptacle. The contacts can only be inserted into the housings one way. They should push in fairly easy. **Do not force the contact into the housing.** When the contact is fully inserted into the housing, you should hear a "click" as the contact spring latches snap into place. Make sure the wire seal did not pull out of the crimp as the assembly was pushed into the housing. Give the wire assembly a gently tug to insure the contact is latched in place. Install the wedge. You will here a "click" as the wedge snaps into place.

**Remember, the housings have no markings so it is important to pay close attention to wiring diagrams to make sure the wires are all in the proper position.**

**2-14.1.6 Solderless crimp-on terminals and quick disconnects.** There are many types of these terminals available. The main terminals we use are ring terminals, spade terminals and quick disconnects. We sometimes refer to the quick disconnects as fast-ons. Another common crimp style terminal is the butt connector. We do not usually recommend the use of butt connectors. It is hard to inspect a butt connector to make sure the wires are properly crimped into the connector. Also, butt connectors are not weather proof and many times these connectors are used in harsh environment areas. If butt connectors are used, the finished connection should be protected with a glue filled shrink tube. In the few instances we supply a harness with butt connectors, we also provide the shrink tube. One connector we do not approve of is the Scotch Lock type connector. ***When two or more wires are spliced together, the approved method is to solder and shrink tube the splice.***

Most crimp on terminals are available with insulated or non-insulated wire crimp areas. Quick disconnect terminals are available fully insulated, both the wire crimp area and the terminal connection area. Many terminals including butt connectors are now available with some type of shrink tube that protects the wire crimp from moisture and corrosion. When using these terminals, it is important to contact the manufacturer to obtain crimping and heating information for the assembly of the wire and terminal. Some of these terminals need to be assembled with a specific tool to eliminate damage to the terminal during assembly. ***It is important to understand that insulated terminals are NOT weather tight. The wire crimp must be protected from corrosion if the connector is used in a harsh or wet environment.*** When using a solder-less terminal in a wet environment, it is best to use a non-insulated terminal and cover the wire crimp with a glue filled shrink tube. Make sure the shrink tube covers the end of the crimp as well as any bare wire. If the end of the crimp is not covered, the wire crimp will still corrode, ruining the connection.

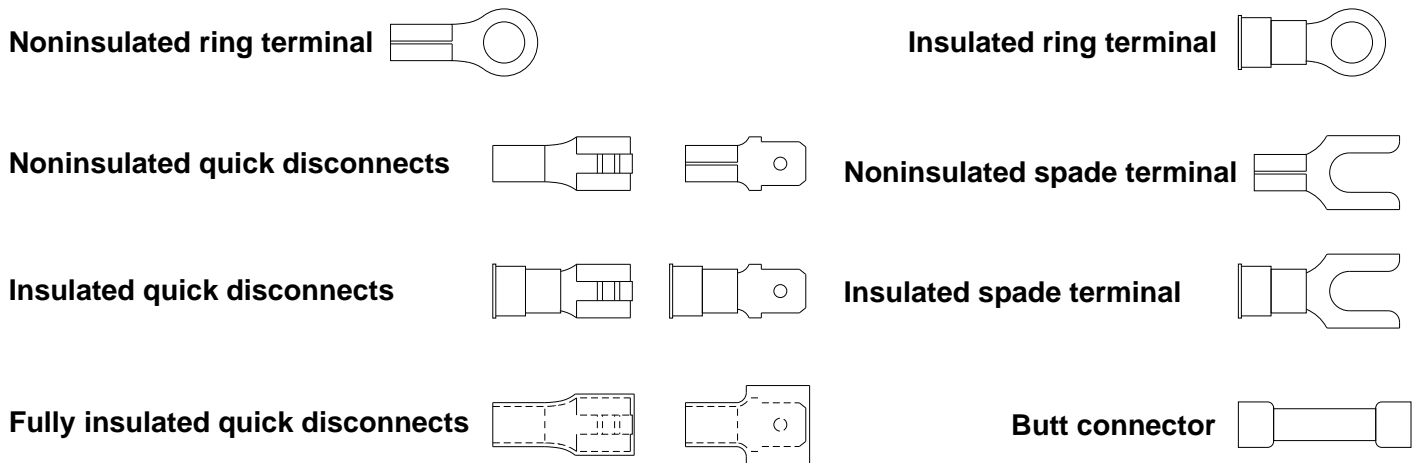

**Fig. 60**

There are different terminals for different gauges of wire. Normally one size terminal will do 10-12 gauge wire, the next size is for 14-16 gauge wire and the smaller crimp-on terminals will do 18-22 gauge wire. It is important to get a terminal with the correct barrel (wire crimp area) for the wire size that is used. It is also important to use a terminal with the correct size of terminal connection. Do not use a ring terminal for a ¼ inch stud or bolt when a #10 bolt or stud is used. Do not try to drill ring terminals to a larger size. This will weaken the terminal and lower the current capacity of the terminal. It is acceptable to crimp more than one wire into a solderless terminal but only if the barrel of the terminal is large enough to accept more than one wire.

***Shrink tube*** is available in different sizes and with or without some type of sealing glue. Make sure the correct size of shrink tube is used when necessary. Too large a size may not shrink down enough to protect the connection. Too small a size may shrink too much and split. This also will not protect the connection.

**Crimping solderless terminals.** To start, always use a good quality crimping tool. The heavier the crimping tool is the easier it is to obtain a good, solid crimp. If using a special terminal, check if the manufacturer requires a special crimping tool. For stripping insulation from the wire, use a wire stripper that is designed to be able to strip specific wire gauges. Do not strip more insulation from the wire than is needed. Normally, about ¼ inch is adequate. Do not use side cutters or a knife to strip wire. This could nick some of the wire strands causing them to eventually break. This will decrease the current carrying capability of the wire. Many crimping tools have a hump on one half of the crimp and a half circle on the other half of the crimp. Most solderless terminals have a closed barrel for the wire crimp. This barrel usually has a seam. When crimping the terminal, make sure the hump of the crimp tool is placed opposite the barrel seam. This will keep the seam from spreading when the crimp is made.

### HEAVY DUTY CRIMP TOOL

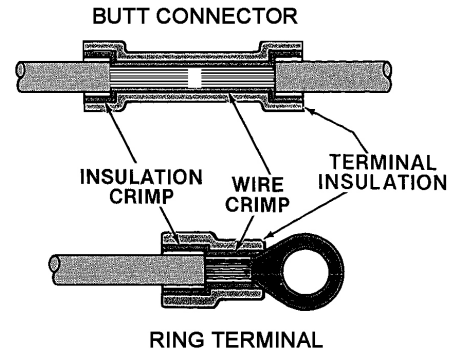

Fig. 61

## 3. ELECTRICAL TEST AND REPAIR EQUIPMENT.

The first section explained how different electrical components function along with basic diagnostics for those components. This section will deal with the test and repair equipment needed to put the first section to work. The two main pieces of test equipment we will discuss are the test light and the volt meter or multi-meter.

**3-1 TEST LIGHTS.** There always seems to be a discussion about what is the best piece of equipment to use when testing electrical equipment. Many instructors I have talked to and many books I have read refuse to even give the test light a passing mention about its value. One instructor I knew made his students throw their test lights away when they started the school. The test light is a valuable piece of test equipment. It is certainly true that a test light will not give you a voltage reading, but it will give you a “go/no go” indication. Testing a relay is a good example. Our pump and master relays are four post relays. The large posts are the contacts and the small posts are for the coil. Do you have power to the relay? Do you have power through the contacts of the relay? Do you have a ground for the coil? Do you have power to the other side of the coil? These are questions that can be answered accurately with a test light. And in many cases because of the location of the equipment, it is easier to access the relays with a test light instead of trying to find a way to read the meter while holding the leads in place. It may be necessary to use a meter in cases when a voltage problem is suspected, but most of the equipment we use will operate at a low enough voltage that a test light normally will give you the information you need to make a repair. A relay will turn on with 8.0 volts. If you have less than 8.0 volts, your test light will be dim. **Like all tools, you need to know your test light. Also, you get what you pay for. Buy a good test light and know its capabilities. IF YOU ARE NOT SURE OF YOUR TEST LIGHT OR THERE IS ANY SUSPICION OF A VOLTAGE ISSUE, CHECK THE VOLTAGE WITH A METER BEFORE CHANGING PARTS.**

**Remember, the statements made in this school are based on experience with the equipment used by HWH and do not necessarily apply to everything that you will work on in the RV industry.**

Here are some rules for using the test light for diagnostics:

1. Know your light. Know the difference between “bright” and “dim”. At what voltage do you start to notice a difference?
2. Know the equipment you are testing. At what voltage will the equipment function? ***Should you use a test light on certain pieces of equipment?*** Although most of the HWH equipment is designed so a test light can be used, **some equipment can be harmed by using a test light.** The Hall Effect switches and pressure transducers (not pressure switches) we use should not be tested with a test light. There are other pieces of equipment this is true of. Do not use a test light on printed circuit boards unless a service manual or service representative directs you to do so. **If in doubt, ask.**
3. Know the voltage you are dealing with. A 12 volt test light will burn out quickly on a 24 volt system.
4. Be careful with the test light probe. Because of the length of the probe, it is easy to create a short to ground when testing a + voltage source. It is a good idea to cover all but approximately ¼ inch of the test light probe with shrink tube to insulate the probe. Many newer test lights have this done.
5. Make the end of the probe a little dull after purchasing the light. This will keep you from piercing the wire insulation with the test light probe.
6. Remember a test light assembly is like two large gauge wires with a very small gauge wire connecting the two. A test light can and will complete an open circuit that could cause a component to turn on. How much of a load a test light could turn on will depend of the test light. This can be a useful feature of the test light but could also create a safety issue. **Know what you are testing so you do not create a hazard.**
7. Make sure the test light is working. Check the light with a known good ground and + voltage source.

**3-1.1 Selecting a test light.** As was stated earlier, “you get what you pay for.” Don’t skimp on price when purchasing test equipment. Get a good quality, reliable test light with a durable cord and insulated alligator clip. I like a light with a medium length insulated probe and a coiled wire. I do not like the LED test lights. It is easier to see a difference between bright and dim with a standard bulb. There are many different styles with different features such as ground or + voltage detection. There are also kits available that come with pin adaptors that allow the light to be easily connected to different plugs. It is a good idea to purchase a test light that has an easily replaceable bulb. ***Purchase a test light that you are comfortable with using and understanding.***

**3-2 DIGITAL MULTIMETERS, VOLTMETERS, ETC.** Although in the Test Light section we discuss the usefulness of the test light, you can only get an accurate measurement of voltage or resistance with a meter. **That is why it is important to know how to use YOUR meter.** This section is not going to explain how to use a particular meter. There are many different styles, brands and price ranges when considering meters. This section will discuss general information to aid in the use and selection of Multimeters.

**3-2.1 Selection of a meter.** Up to a point, how much you spend on a meter should not be a consideration. There are very inexpensive meters available but again, you get what you pay for. \$30 won’t buy you much of a meter. That doesn’t mean you should run out and spend \$500 or \$600 either. The two main considerations when purchasing a meter are quality and features. For quality, do some shopping. Talk to several experienced techs and get some opinions. Whether it’s from an on site tool truck or a supply catalog, make sure warranty and service is readily available for the meter. For features, you need to understand what you are going to work on. If your work is limited to HWH type equipment, you won’t need the same features in a meter that a tech working on generators, converters and inverters may need. When comparing Digital meters you will hear the term “True RMS” as a meter feature. If you need “True RMS” (Root-Mean-Square) explained, you don’t need this feature. If you are a tech that understands “True RMS”, you probably already have a “True RMS” meter. Please do not take offense to this. As a tech working only with HWH equipment, I did not know what a True RMS meter was good for nor did I care. In fact, although I now understand “True RMS”, I still don’t care if I am using a True RMS meter. I only bring up the subject to help you decide on a meter. Don’t spend money you don’t need to. You can always upgrade someday if necessary.

Another choice is between a digital or analog meter. The digital meter is by far the most popular among service techs. The digital meter is easier to read and less awkward to use than most analog meters. My preference is a digital meter BUT there is one advantage to an analog meter. If you are looking for a voltage spike or dip, a digital meter may not react quick enough to catch the spike or dip. The needle of the analog meter will react to the spike or dip. This could be a useful feature but I still recommend a digital meter. It just may be helpful to know where to get your hands on an analog meter if you need one.

These are a few things I would look for in a digital meter:

1. Quality
2. Serviceability
3. Auto Range feature.
4. Relative mode. Everything has resistance, even the meter probes. The Relative Mode compensates for the probe resistance to give you an accurate reading when measuring resistance. You simply hold the probes together and push the REL button. This will “0” out the meter.
5. Adaptability. Will the meter accept and have available accessories such as alternate style probes, clamp on amp meter or a temperature probe?
6. Price.

**3-2.2 Digital multimeter functions.** Most digital multimeters will have the same standard functions. The more expensive the meter, the more functions the meter may have. In this section we will concentrate on the standard functions as these are the functions you will need when diagnosing HWH equipment.

These are the symbols that will be on the meter selector dial:

 This is for measuring Volts AC (Alternating Current). Normally you will not need this scale but we have done a few 110 volt pieces of equipment.

 This is for measuring Volts DC (Direct Current). This will be the main scale that you will use.

 This is for measuring Milli-Volts DC. This scale reads thousandths of a volt. If mV is preceded by a number such as 300, that means this scale will read up to .300 of a volt. To read a greater voltage, you have to go to the V scale.

$\Omega$  This is for measuring resistance or ohms. Most meters will have multiple ranges. These ranges are:  
 $\Omega$  Up to 999 ohms depending on the meter  
 $K\Omega$  Up to 999,999 ohms depending on the meter  
 $M\Omega$  1,000,000 or more ohms  
Most meters will have an auto range function or a manual range function. The auto range function will automatically range needed to read the resistance. The manual range function is just what it says. You pick the range you want to work in. The auto range function is what most people usually use.

 This is a diode test.

 This function is an audible “beep” indicator for continuity.

A This is for measuring amps or current, either AC or DC. Less expensive meters may have a separate selection on the dial for Amps AC and Amps DC. The dial may also be marked mA to measure milli-amps or thousandths of an amp. Maximum measuring capability for most meters is 10 amps.

$\mu A$  This is for measuring micro-amps or millionths of an amp. This may be on more expensive meters.

**3-2.3 Reading the digital multimeter.** The best thing I can say about learning to read a digital meter is to study the manual that comes with the meter. The screen of the meter will give you the information that you need but different meters will have different ways the information is presented. For example, I have one meter that on the right side of the screen it will indicate VAC (Volts AC) or VDC (Volts DC). My other meter (a more expensive unit) indicates V (Volts) on the right side of the screen for both AC and DC volts measurements. On the left side of the screen it indicates AC for AC volts measurements and nothing for DC volts measurements.

There are two main things that you have to pay attention to while reading the meter. First is any letters, words or symbols on the screen after you select a function and when you take a reading. This tells you the function and range the meter is operating in. The second thing is where the decimal point is. Most meters will have multiple ranges. Each range starts at 0 (the screen might show 0.00 but that is still 0) and will have a maximum. Using the Auto Range feature, if the meter is so equipped, is usually the easiest. The meter will automatically pick the range (not function) that is needed. You just note the position of the decimal point and the letter indicating the range to get the correct reading. Some meters have a range maximum in multiples of 2, 3, or 4. For example, a meter with a multiplier of 4 would have the following ranges when the dial is set to  $\Omega$ .

- 400  $\Omega$  0 to 400 ohms 400 ohms is the maximum reading for this range.
- 4 K $\Omega$  0 to 4,000 ohms 4,000 ohms is the maximum reading for this range.
- 40 K $\Omega$  0 to 40,000 ohms 40,000 ohms is the maximum reading for this range.
- 400 K $\Omega$  0 to 400,000 ohms 400,000 ohms is the maximum reading for this range.
- 4 M $\Omega$  0 to 4,000,000 ohms 4,000,000 ohms is the maximum reading for this range.
- 40 M $\Omega$  0 to 40,000,000 ohms 40,000,000 ohms is the maximum reading for this range.

If using manual range selection the screen will indicate OL for over limit whenever the range limit is exceeded. Some meters may have a different indication. One of my meters indicates OUCH whenever a range limit is exceeded.

It is important to understand the range symbols and how to translate the figures.

<b>M is MEGA</b>	MEGA is x(1,000,000)	6.4 M $\Omega$ is 6,400,000 ohms
<b>K is KILO</b>	KILO is x(1,000)	21.3 K $\Omega$ is 21,300 ohms
<b>m is milli</b>	milli is .001 or 1/1000	329 mA is .329 amps
<b><math>\mu</math> is micro</b>	micro is .000001 or 1/1,000,000	6,729 $\mu$ A is .006729 amps

The symbol **M** moves the decimal point 6 spaces to the right.

The symbol **K** moves the decimal point 3 spaces to the right.

The symbol **m** moves the decimal point 3 spaces to the left.

The symbol  **$\mu$**  moves the decimal point 6 spaces to the left.

The following example is what a meter with a maximum multiplier of 4 would read when measuring a circuit with 36,178 ohms of resistance when using the manual mode in all the  $\Omega$  ranges:

- 400  $\Omega$  – OL
- 4 K $\Omega$  -- OL
- 40 K $\Omega$  – 36.18 K $\Omega$
- 400 K $\Omega$  – 36.2 K $\Omega$
- 4 M $\Omega$  -- .036 M $\Omega$
- 40 M $\Omega$  -- .04 M $\Omega$

In the AUTO mode, the meter will automatically go to the smallest range the read the resistance. The AUTO range would go to the 40 K $\Omega$  range and read 36.18 K $\Omega$

Some meters just use a straight reading for each range,  $\Omega$  is 0 to 999, K $\Omega$  is 0 to 999,999 and M $\Omega$  is 0 to 1,000,000 plus. **Whether in AUTO or manual mode, you must know how to read the ranges or scales on your meter.**

Here are a few problems to practice converting meter readings from one scale to another. The answers are at the end of this section, **3-2.4**. Don't worry about a maximum multiplier or rounding the numbers off. These may not be readings you will see on your meter. This is just to help you understand how to transpose the numbers.

- |                                     |                                     |
|-------------------------------------|-------------------------------------|
| 1. $42.3 \Omega =$ _____ $K\Omega$  | 6. $.625 A =$ _____ $\mu A$         |
| 2. $1.73 M\Omega =$ _____ $K\Omega$ | 7. $8.36 V =$ _____ $mV$            |
| 3. $236 mV =$ _____ $V$             | 8. $147,568 mA =$ _____ $A$         |
| 4. $639.7 K\Omega =$ _____ $\Omega$ | 9. $22.35 M\Omega =$ _____ $\Omega$ |
| 5. $36.1 \mu A =$ _____ $mA$        | 10. $.71mV =$ _____ $V$             |

**➤ Diode Check.** Refer to section **2-5** for the correct information on testing diodes. The important thing to remember about checking a diode is if the diode is installed on a circuit board or is in a circuit with other components, the diode test may not be accurate. One of the diode legs needs to be disconnected from the circuit to get accurate test results.

**))) Audible “beep” continuity test. The “beep” test is only a basic test for continuity. It is not a very accurate test. Most meters will “beep” with up to a hundred ohms of resistance, some at a higher level.** Here are a couple of examples why the “beep” test is not a reliable test. Example 1: A 100 foot piece of 16 gauge wire only has .2525 ohms of resistance. The “beep” test certainly does not tell us that piece of wire is not damaged. If the 100 foot piece of 16 gauge wire was cut and is now only equivalent to a 30 gauge wire, it still would only have 10.32 ohms of resistance. The damaged wire could cause a significant voltage drop causing a piece of equipment to fail even though the “beep” test indicated continuity. Example 2; A circuit with a load that has a coil with approximately 1 ohm of resistance, such as our hydraulic solenoid valves, has a wire that was tested by someone poking a test light into the wire. The wire now has a corrosion resistance of 1.5 ohms. With a system voltage of 12.5 volts, the voltage drop across the corrosion is 7.5 volts. The solenoid valve will not work because of the wire but the “beep” test showed good continuity through the wire. I am not saying to never use the “beep” test, just **don't rely on the “beep” test to be conclusive in connection and resistance issues.**

**3-2.4 Using the multimeter.** The two main things you will use the multimeter for are checking voltage and resistance. These two checks will take care of continuity tests. Remember, the “beep” test is very inconclusive. The diode test is not a very common test either. If a diode is causing an issue with a circuit board, you don't have to diagnose the bad diode. If a circuit board is failing, we replace the board, not internal components. If the problem diode is in a harness, power is getting through when it shouldn't or power isn't getting through when it should. Either way, a voltage test will show the problem. Even checking resistance will not be very common when compared to checking voltage.

The main thing to remember when **checking resistance** is that **the circuit must be off**. It is also best that the circuit or component is isolated. The main problem with checking circuit or component resistance is obtaining a resistance value. The other issue is the capability of the meter that is available. For example, our large solenoid valve coils only have approximately 1.2 ohms of resistance. Without a meter with a “relative” function, you cannot get an accurate measurement. Here are some resistance values for several gauges of stranded wire. These values are per 50 foot of wire at 68 degrees Fahrenheit.

- 10 gauge--.054 ohms
- 12 gauge--.0855 ohms
- 14 gauge--.1365 ohms
- 16 gauge--.2175 ohms
- 18 gauge--.346 ohms

As you can see, you need the size and length of wire to determine resistance of the wire in the circuit. Even small gauge wires have a very low resistance factor. Voltage drop for individual components is the best way to diagnose component issues.

Using a meter to check **voltage** is the most reliable and accurate way to check voltage and corrosion or connection issues. (I still like a test light for initial quick tests especially when a component will not function at all.) Checking voltage drop is the best way to diagnose a circuit. There are three main things to do when checking voltage drop with a meter:

1. You want to check as close to the component with the component plugged in as possible. This should be the component connector or connection post. If necessary, use some type of jumper wire to make this possible. We have some special adaptors to make this possible.
2. Always check voltage between the + voltage supply and the ground connection for the component. This could be a wire, a mounting bolt or a special ground connection such as a ground stud. **Do not use a separate frame ground for the initial check.** If the problem is the ground for the component, you could get an acceptable voltage reading using a frame ground. If the initial reading indicates low voltage, then use a known good ground to make a check. This will let you know if the ground is the problem.
3. **You must have the component or a load turned on to check voltage drop.** Checking voltage with no load will not give a correct reading for the voltage drop across a component. Even long runs of wires or diodes in the circuit will not cause a voltage drop if there is no current flowing through the circuit. The only way to create a current flow is by having a load on the circuit.

Using the voltmeter **to find an open in a circuit** is a simple process and usually has only one issue, tracing the circuit through the vehicle. (You can also do this with a test light.) I like to start at the + voltage source and work my way to the load. Measure the voltage to a known ground. If possible, using the ground source for the circuit is the best. You might find the ground is the issue before going too far. As you work your way through the circuit, the voltage should be the same. If there is any voltage differences as you go, there is some type of load on the circuit. The open in the circuit is somewhere between the last good voltage reading you got and the first 0.00 reading you get.

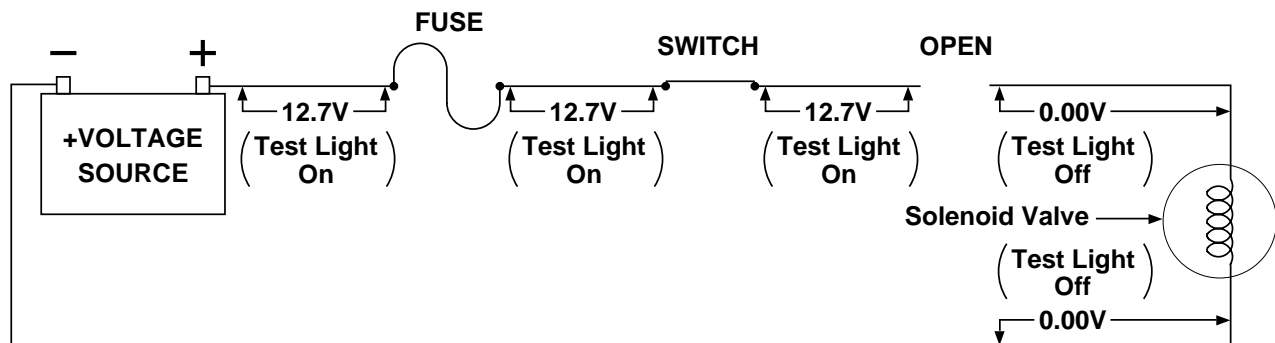

Fig. 62

Review the other sections of this school. There are a lot of good examples of how to check circuits and system components.

Answers to the exercise in the “Reading the digital multimeter” section.

1. .0423 K $\Omega$
2. .00173 K $\Omega$
3. .236 V
4. 639,700  $\Omega$
5. .0361 mA
6. 625,000  $\mu$ A
7. 8,360 mV
8. 147.568 A
9. 22,350,000  $\Omega$
10. .00071 V



**3-3 OTHER TEST AND REPAIR EQUIPMENT.** There is any number of pieces of equipment you could own but most of what you need has already been discussed in this school. However, there are some things that you will need or find useful when working on HWH equipment.

**3-3.1 Clamp-on amp meter.** This meter is necessary to check the current draw of pump motors. (Most digital multimeters are only good for testing up to 10 amps.) This meter is available several different ways. It can be purchased as a stand alone meter. It can also be purchased, in most cases, as an accessory for your digital multimeter. The accessory amp meter will have a dial to zero out your multimeter. The multimeter has to be set to the mV scale on the selector dial. Then you clamp the amp meter around the cable supplying + voltage to the pump motor. With the pump motor running, read the number on the multimeter screen. You may want to take a voltage reading at the same time.

**3-3.2 Wire strippers.** There are many different types of wire strippers available. Sometimes a crimping tool will have wire stripping capabilities. The automatic wire strippers are my favorite. I suggest a stripping tool with multiple wire gauge holes that are labeled. When the wire is inserted into the proper hole and the handles are pulled, the wire insulation is cut to the correct depth and then the wire is pulled to remove the cut piece of insulation. **Just make sure you use a good stripper, no teeth, knives, wire cutters or nail clippers.**

**5-3.3 Test leads.** Like everything else, test leads come in all sizes, shapes and forms. The main thing to remember about a test lead is it is just a wire, so it needs to be sized properly so it does not add to the circuit problem. This is especially important when using the lead as a jumper to run a piece of equipment. I have several different leads I use. I have a fairly long lead with a 12 gauge wire. I have another similar lead that has an automotive style fuse holder. Both of these leads have alligator clips on both ends. I have several different leads in a smaller gauge wire that have one or two pin male or female Packard connectors. These are useful when dealing with components like warning switches or pressure switches. I also have an adaptor that plugs in between the harness and air or hydraulic solenoid valves. This adaptor has a positive and negative lead with alligator clips. I can connect my volt meter to the adaptor to monitor voltage to a valve with the valve plugged in and energized. It is also a good idea to have a 6 or 8 foot number 2 battery cable with clamp ends applied. This can be used to supply + voltage to a pump motor or to supply a ground for the pump motor. Whatever you have, make sure you have an assorted supply of good test leads and jumper wires or cables. No bare wires, coat hangers or screwdrivers please. HWH has an assortment of jumpers and test leads or test harnesses available to ease diagnostics on HWH equipment. Most of these are listed in our parts catalog that can be viewed on line at [www.hwh.com](http://www.hwh.com).

#### ASSORTED TEST LEADS

Multi-purpose voltage and ground test pigtail. This pigtail will plug in between any component with a 2-pin Packard connector and its harness connection. It allows you to check voltage drop.

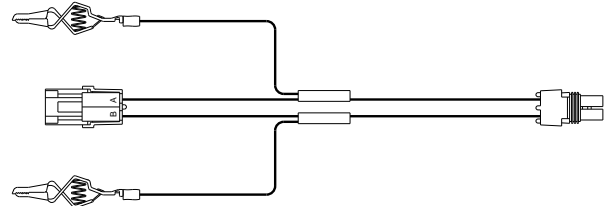

Multi-purpose switch test pigtail. This connector has a black and a gray 2-pin Packard connector. This pigtail plugs into the harness not the component.

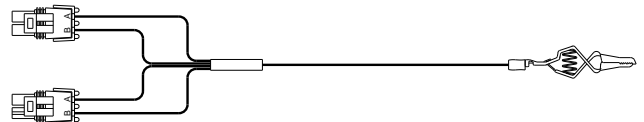

Single wire switch test pigtail. This connector has a black 1-pin Packard connector. This pigtail plugs into the harness not the component.

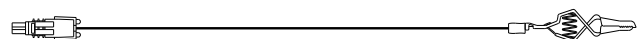

**Fig. 63**

**3-3.4 Soldering equipment.** We recommend that when wires need to be spliced and some type of connector is not used, the splice is accomplished by soldering the wires together. Butt connectors should rarely be used and are not as reliable as soldering. If the right equipment and solder is available, soldering does not take much more time than crimping some type of connector. If you are repairing a pin type connection, we do not recommend soldering. Fix the connection with a like connector.

Several basic types of soldering tools are available. There is the soldering gun, stylus type electric soldering irons and the butane powered soldering irons. Among these are many brands, styles and price ranges. I like the butane irons. They are totally portable and the tips heat very rapidly. Most butane kits also come with attachments that will heat the shrink tube that should be used over every solder splice. You only need the one kit to do the job.

After selecting a soldering tool, you need the correct solder. A small diameter, flux core solder is the easiest to work with. We use a .032 diameter flux core solder. **Do not use an acid core solder on electronics. The acid core solder will create a corrosive effect.**

A soldering technique is something you have to develop for yourself. Practice with the soldering tool you choose so you are used to it when the time comes for an actual repair. Here are some soldering tips:

1. Give yourself, when possible, plenty of bare wire to work with so you can tightly twist the splice wires together. Do not try to solder corroded wires or terminals.
2. Remember to put the shrink tube onto one of the wires BEFORE you solder the splice. Don't let the shrink tube get too close to the splice while soldering. You don't want to shrink the tube before it is in place.
3. Don't get the wires too hot. This can damage the wire insulation and cause shrink tube to shrink before it should.
4. Don't try to "coat" the splice with solder. Heat the wire so the solder can "wick" into the wire strands. Apply the heat to the bottom of the splice if possible. A small drop of solder on the soldering tip can help transfer the heat to the wire when the tip is applied to the wire.
5. Don't use too much solder. Excess solder could cause a problem for the shrink tube. Excess solder can "wick" up into the wires, damaging insulation. This will also cause the wire to be stiff away from the splice. When all the visible wire strands are coated, that is enough solder.
6. Allow the splice to cool slightly before trying to move the shrink tube into place. Too soon may cause the shrink tube to stick before it is in the proper position.

---

This is the end of this school at this time. There may be future additions to this such as a schematic or diagram reading section. Check the school outline from time to time. We will mark future additions as "New". I hope this has been informative and helpful. Remember, this school is based on information pertaining to equipment and diagnostics that is used by HWH Corporation.

The following is a test that will cover a little of everything that was discussed in this school. Down load the test and email it to [school@hwh.com](mailto:school@hwh.com), we will correct it and send it back to you.

We appreciate any input that will help make this and other online HWH schools better. If you find mistakes, feel free to let us know so we can correct it.