

## X5L



- Extra vacuum level to 27.9 -inHg
- Small size and low weight
- Use in tightly sealed or non-porous applications

Supplied with push-in hose connector for compressed air (for pumps for connection plate A & B2). Supplied with push-in hose connector for compressed air and external flow-through silencer (for pumps for connection plate C).

### Technical data

Description	Unit	Value
Feed pressure, optimum	psi	58
Feed pressure, max.	psi	101.5
Noise level	dBA	62–66
Temperature range	°F	-4-176
Weight	oz	1.16 (A), 2.19 (B2), 1.69 (C), 0.46 (Z)
Material		PA, POM, SS, NBR (Viton/EPDM), Al (B2 only), ABS (C only)

### Vacuum flow

Feed pressure psi	Air consumption scfm	Vacuum flow (scfm) at different vacuum levels (-inHg)										Max vacuum -inHg
		0	3	6	9	12	15	18	21	24	27	
58	0.83	1.02	0.51	0.25	0.23	0.21	0.18	0.15	0.12	0.06	0.01	27.4

### Evacuation time

Feed pressure psi	Air consumption scfm	Evacuation time (s/cf) to reach different vacuum levels (-inHg)									Max vacuum -inHg
		3	6	9	12	15	18	21	24	27	
58	0.83	4.82	23.2	48.2	76.5	110	153	210	300	637	27.4

See page 28 for recommended hose dimensions for compressed air, vacuum & exhaust connections.

## Ordering information

	Description	Part No.
A	Vacuum pump MINI X5L, conn. A, NBR seals	X5A5-AN
A	Vacuum pump MINI X5L, conn. A, NBR seals, non-return valve	X5A5-ANA
B	Vacuum pump MINI X5L, conn. B2, NBR seals	X5A5-B2N
C	Vacuum pump MINI X5L, conn. C, NBR seals	X5A5-CN
C	Vacuum pump MINI X5L, conn. C, NBR seals, non-return valve	X5A5-CNA
D	Vacuum pump MINI X5L, conn. Z, NBR seals	X5A5-ZN
D	Vacuum pump MINI X5L, conn. Z, NBR seals, non-return valve	X5A5-ZNA

Viton® or EPDM seals optional (i.e. Part No. X5A5-AV or X5A5-AE)

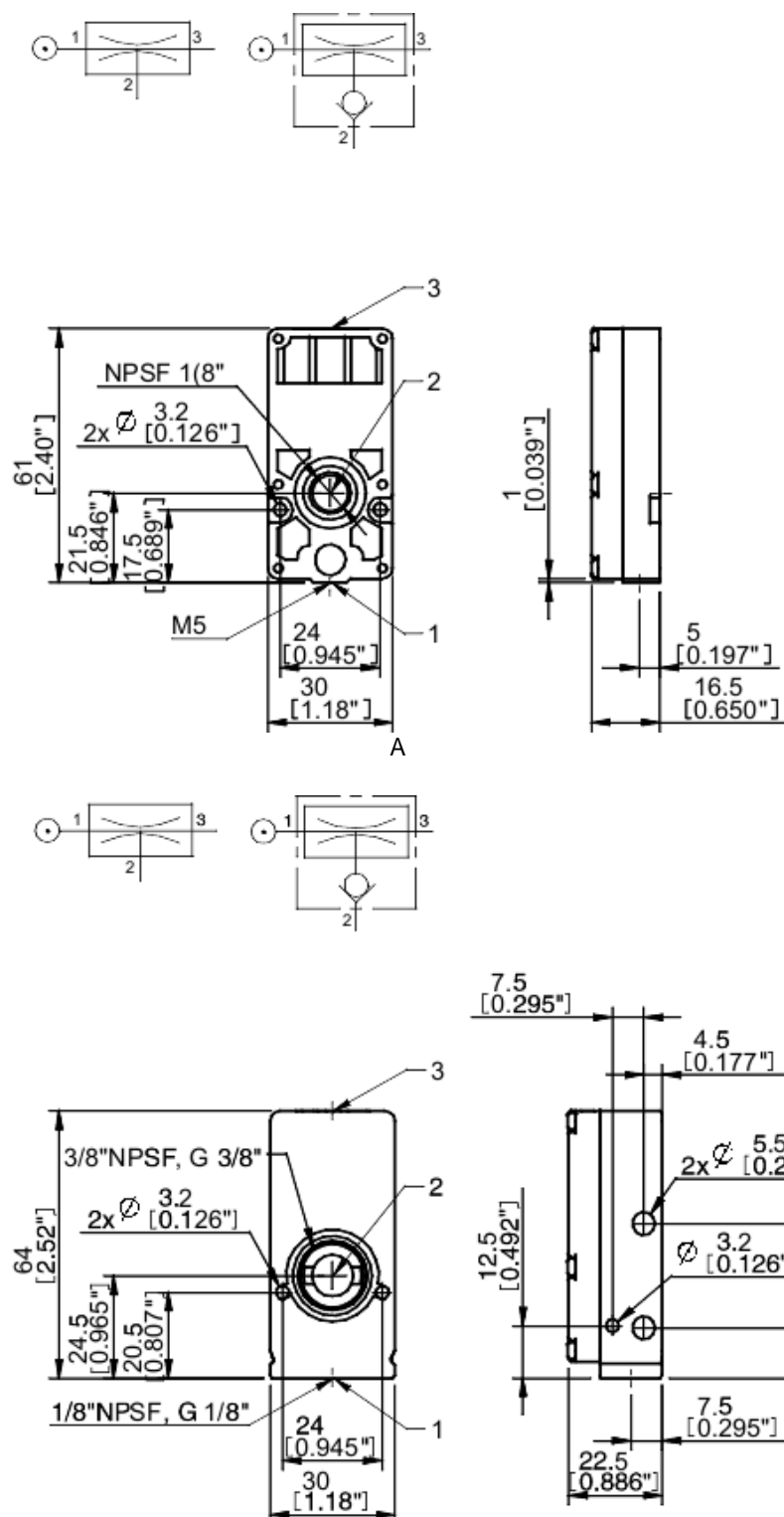

B

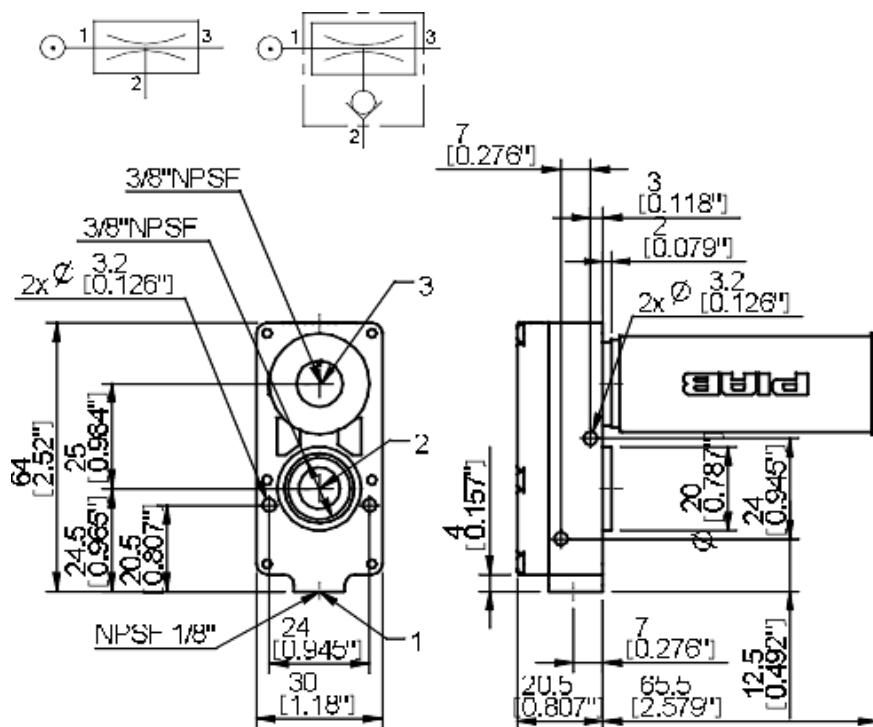

C

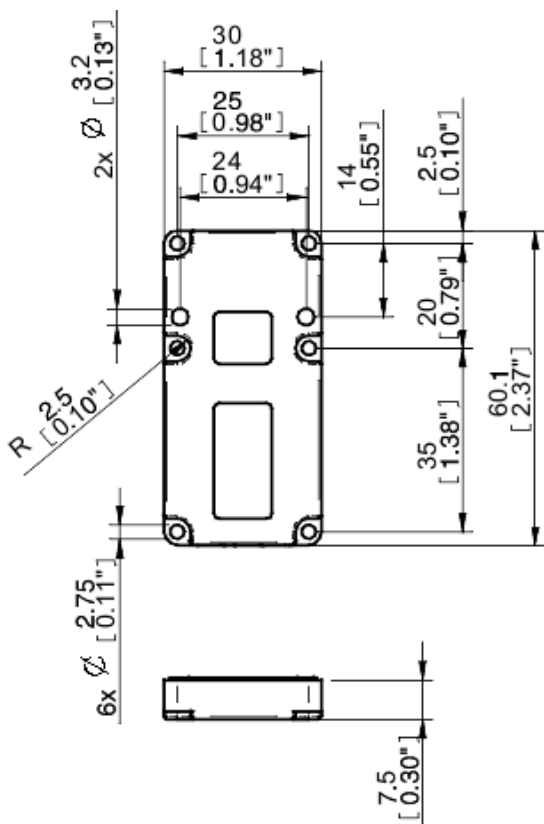

D

Ordering information, accessories

Description	Part No.
Seal kit MINI 5-28, NBR	32.01.097
Seal kit MINI 5-28, Viton®	32.01.097V
Seal kit MINI 5-28, EPDM	32.01.097E

*Seal kits include flap valves, gaskets and compressed-air filters.*