

7 TOOLS

Section	Page
7.1 DIAGNOSTIC REQUEST SWITCH	7-3
7.2 VEHICLE ELECTRONIC PROGRAMMING SYSTEM	7-5
7.3 DIAGNOSTIC DATA READER	7-7
7.4 DETROIT DIESEL DIAGNOSTIC LINK	7-27
7.5 DDEC REPROGRAMMING SYSTEM	7-29
7.6 DDEC ENGINE PROTECTION SIMULATION KIT	7-35
7.7 DDEC MANUALS	7-37

THIS PAGE INTENTIONALLY LEFT BLANK

7.1 DIAGNOSTIC REQUEST SWITCH

The Diagnostic Request Switch is used to activate the CEL/SEL lights to flash codes. Active codes are flashed on the SEL and inactive codes are flashed on the CEL (see see Figure 5-6). Inactive codes are flashed in numerical order, active codes are flashed in the order received, most recent to least recent. The Diagnostic Request Switch can be used as the SEO switch also. The codes are flashed out of the ECM connected to the switch.

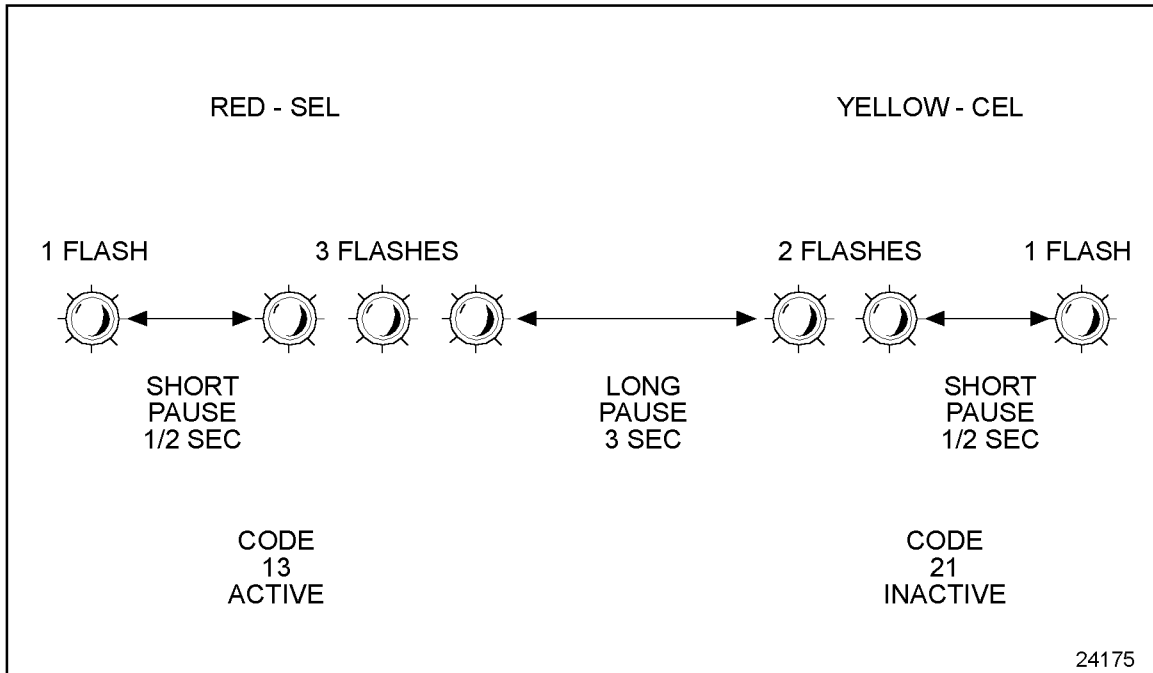

Figure 7-1 Flash Codes

NOTE:

For multi-ECM installations, the Diagnostic Request Switch and SEO are combined on the master ECM. All receiver ECMs have a separate Diagnostic Request Switch.

The Diagnostic Request Switch is used to flash codes in the following circumstances:

- The engine is not running and ignition is on
- The engine is idling and not in an "engine protection" condition

In both circumstances activating and holding the Diagnostic Request Switch will flash out the diagnostic codes. For additional information, refer to section 5.5, "Diagnostics."

THIS PAGE INTENTIONALLY LEFT BLANK

7.2 VEHICLE ELECTRONIC PROGRAMMING SYSTEM

The purpose of the DDEC Vehicle Electronics Programming System (VEPS) is to give OEMs the ability to configure many ECM parameters. This allows DDEC features to be tailored to the specific customer requirements when the vehicle is assembled. Some of the features which may be configured by VEPS are the transmission type, cruise control, vehicle speed limit, idle shutdown, rating switches, digital inputs, and digital outputs. VEPS requires the Windows 95 operating system.

7.2.1 SOFTWARE

The VEPS PC software package consists of the several files which are extracted when the software installation program is executed. A System Users Manual which defines the available parameters is included with the software package at the time of purchase.

The PC interface utilizes a communications driver which is defined in the TMC Recommended Practice RP1210A. The RP1210A software is used to translate the datalink signal of the ECM to the format required by Windows programs. The RP1210A communications driver is included as part of the VEPS software package.

7.2.2 HARDWARE

The hardware portion of the VEPS programming package includes the interface module and cables. The components that are included in the package are listed in Table 7-1.

Part Description	Part Number
100 Foot Cable	23512893
SAE J1708 6-Pin Dash Connector	23515957
J1708/RS-232 Translator Box	23512415
6 foot Cable	23515869

Table 7-1 VEPS Hardware

A cable kit, listed in Table 7-2, is also available.

Part Description	Part Number
Cable Kit (includes the 100 foot cable and the 6-pin dash connector)	23512980

Table 7-2 VEPS Cable Kit

A translator and cable kit, listed in Table 7-3, is also available.

Part Description	Part Number
Translator Kit (includes the J1708/RS-232 translator box, 100 foot cable and the 6-pin dash connector)	23512895

Table 7-3 VEPS Translator and Cable Kit

The VEPS software kit, listed in Table 7-4, is available.

Part Description	Part Number
Software Kit (includes the RP1202 Software and the VEPS Software)	Contact DDC Application Engineering

Table 7-4 VEPS Software Kit

7.2.3 OPTIONAL PARTS KITS

DDC offers vehicle repower kits to aid in the installation of DDEC III/IV.

NOTE:

This is a repower kit for DDEC II to DDEC III only. There are no repower kits for

NOTE:

DDEC IV.

The kits listed in Table 7-5 and Table 7-6 include all of the necessary wiring for the installation of the DDEC III/IV engine and the following parts:

Part Description	Part Number
Terminal Kit	23515326
Vehicle Harness - 30 foot	23515152
Power Harness - 22 foot	23515151
Light and Switch Kit	23501634

Table 7-5 DDEC Repower Kit - DDC P/N: 23515327

Part Description	Part Number
Terminal Kit	23515326
Vehicle Harness - 70 foot	23515153
Power Harness - 22 foot	23515151
Light and Switch Kit	23501634

Table 7-6 DDEC Repower Kit - DDC P/N: 23515328

The harnesses come with ECM connectors on one end and no connections on the other end. These harnesses are intended to be cut to length by the OEM. The harnesses come with all the connections in the ECM connector. Wires can be removed if not used in a specific application.

7.3 DIAGNOSTIC DATA READER

The hand-held DDR plugs into the Diagnostic Data Link Connector located in the Vehicle Interface Harness (refer to section 3.10.7). This connection allows the DDR to receive data from the ECM. The DDR is used to display:

- Engine Description via the ENGINE DATA LIST menu
- Codes via the DIAGNOSTIC CODES menu
- View/reprogram certain operating parameters

A printout of the information displayed on the DDR can be obtained by attaching a printer.

7.3.1 REQUIREMENTS

The components required to receive data from the DDEC system can be seen in the next illustration (see Figure 7-2). The components and part numbers are listed in Table 7-7.

Component	Part Number
Pro-Link Main Unit	J 38500-1A
Multi Protocol Cartridge (MPC)	J 38500-1500C
Detroit Diesel Application Suite PC Card, DDEC III/IV	J 38500-2300D
6 pin Deutsch Adapter	J 38500-60A
6 pin to 9 pin Deutsch Adapter	J 38500-96A
Pro-Link Reprogramming Cable	J 38500-925
Pro-Link Portable Printer	J 38480-A

Table 7-7 Diagnostic Data Reader Components and Part Numbers

NOTE:

Printers used in Europe must use a European power supply as listed in Table 7-8. Do not substitute an AC adapter for the European power supply.

Component	Part Number
Printer (U.S.A.)	J 38480-A
Printer with European Power Supply	J 38699
European Power Supply only	J 38480-220

Table 7-8 DDR Printers and Power Supply

⚠ CAUTION:

To avoid injury from loss of vehicle/vessel control, the operator of a DDEC equipped engine must not attempt to use or read the Diagnostic Data Reader when the vehicle/vessel is moving.

The DDR must be used by personnel other than the vehicle operator. The vehicle operator must maintain control of the vehicle while an assistant performs the diagnostic evaluations.

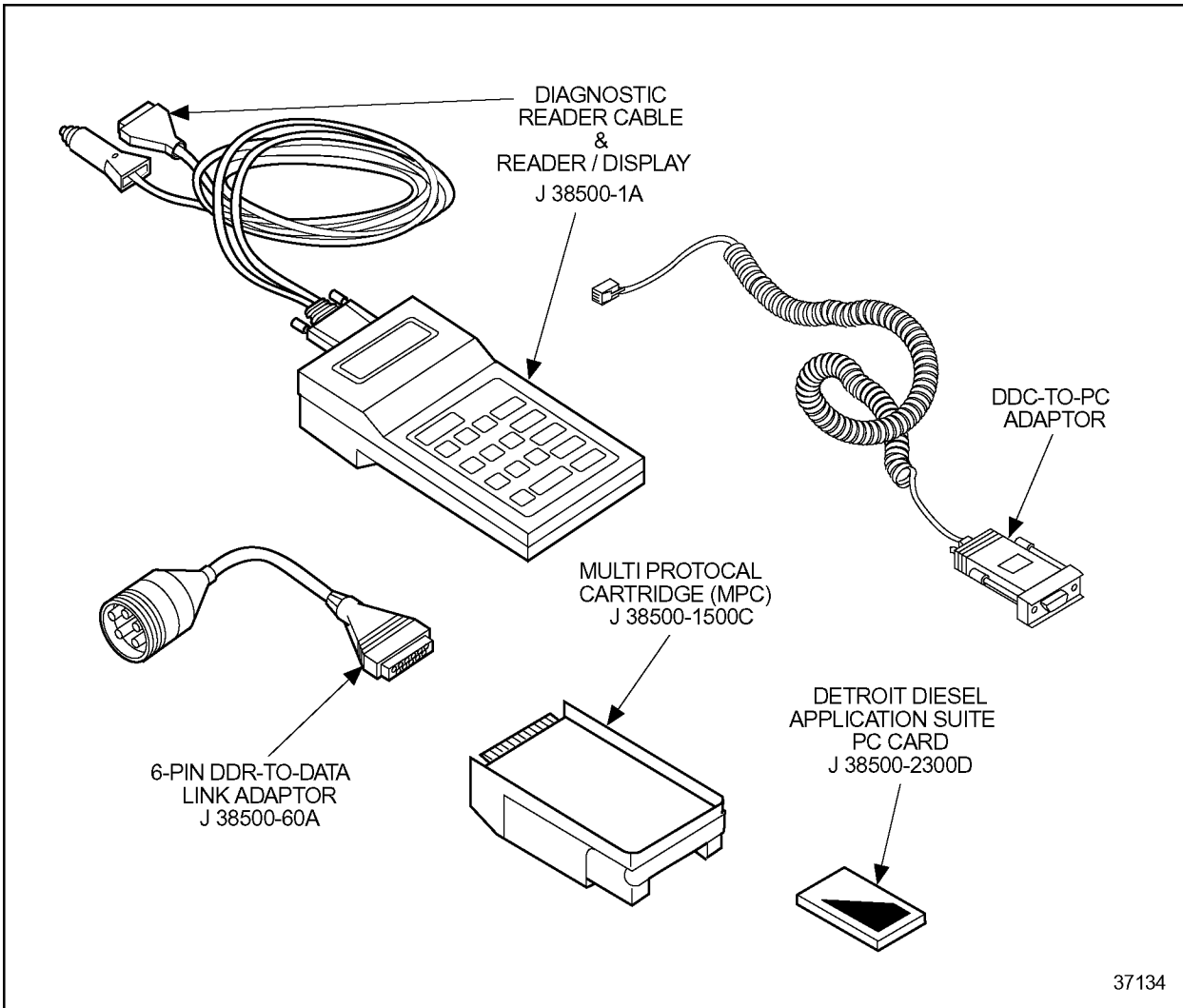

Figure 7-2 Diagnostic Data Reader Kit Plus DDEC Cartridge and PCMCIA Card

The DDR can be purchased from:

Kent-Moore

28635 Mound Road

Warren, MI 48092

Phone: 1-800-328-6657

See Figure 7-3 for a DDR menu options map.

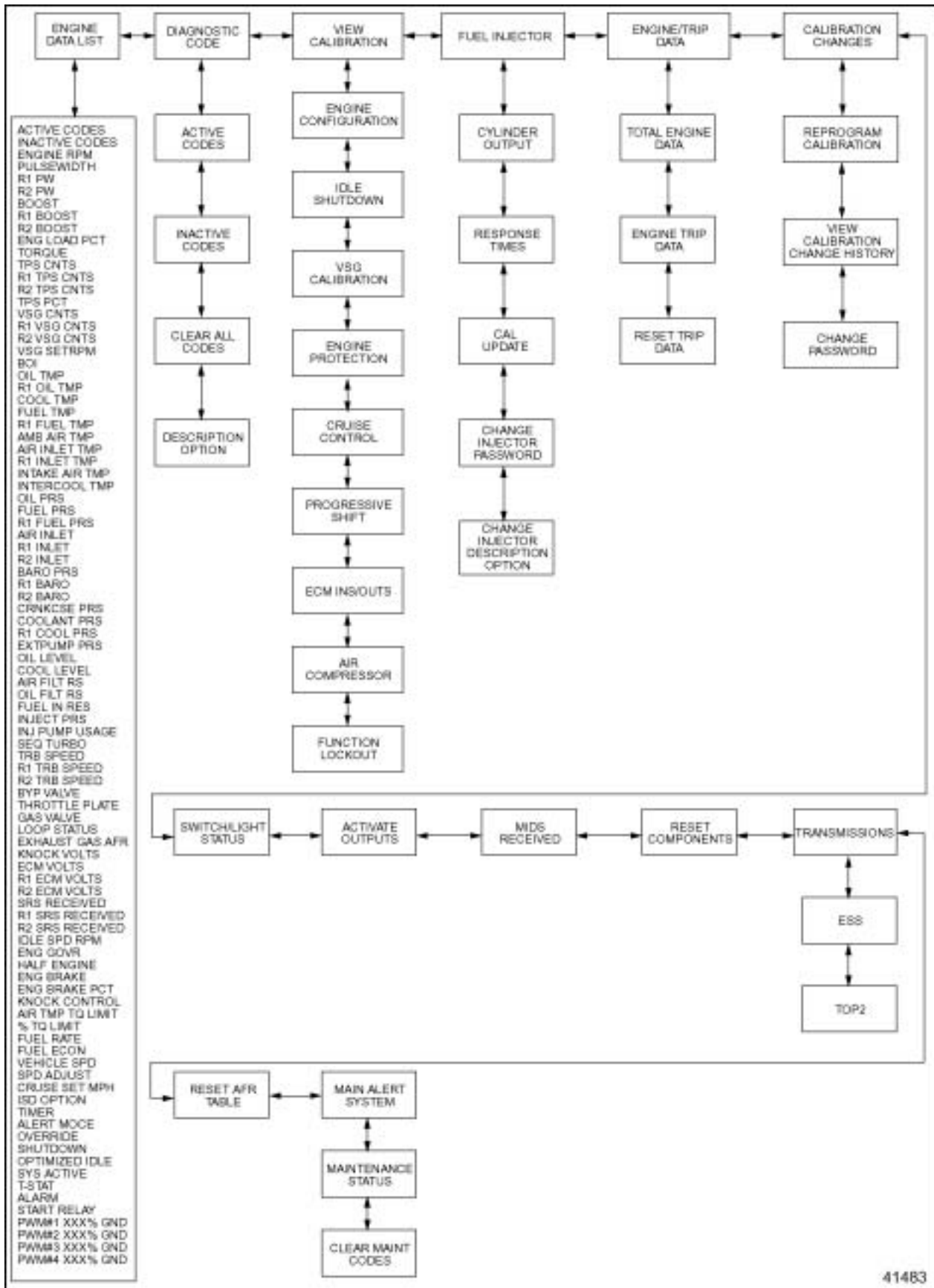

41483

Figure 7-3 DDR Menu Options (Release 24.0 Software)



7.3.2 ENGINE DATA LIST

The DDR can be used to view operational data and parameter settings, via the Engine Data List feature.

View operational data as follows:

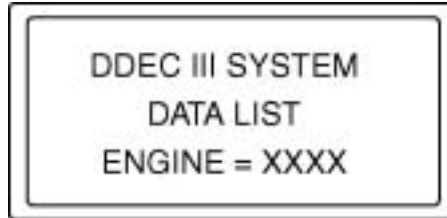
1. Turn the ignition ON.
2. Press  until ENGINE DATA LIST is shown on the screen.



3. Scroll through the data list by pressing  and  until the desired parameter is shown on the screen.

7.3.3 DIAGNOSTIC CODES

The DDR can be used to view active and inactive codes.

Active Codes

View the (active) codes as follows:

1. Press  until the SELECT DESIRED MENU appears on the screen.



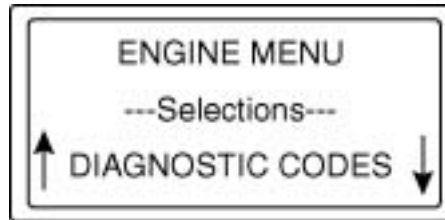

2. Select ENGINE and press .
3. Press  until DIAGNOSTIC CODES is shown on the screen.

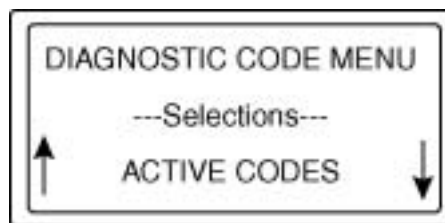

4. Then press .
5. Press  until ACTIVE CODES is shown on the screen.



6. Then press  to view the first active code.
7. Press  and  to scroll through the active codes.

NOTE:

Refer to Appendix A for a list of all DDEC codes and code descriptions.

Inactive Codes

View the inactive codes as follows:

1. Press  until the SELECT DESIRED MENU appears on the screen.



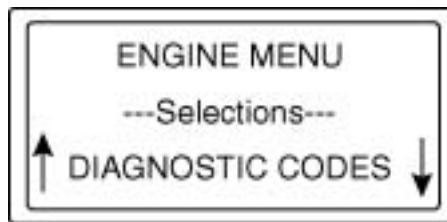

2. Select ENGINE and press .
3. Press  until DIAGNOSTIC CODES is shown on the screen.

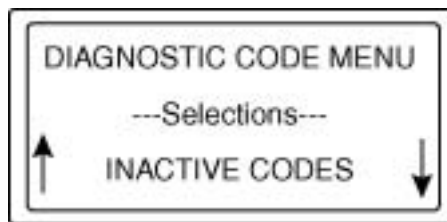

4. Then press .
5. Press  until INACTIVE CODES is shown on the screen.



6. Then press  to view the first inactive code.
7. Press  and  to scroll through the inactive codes.

NOTE:

Refer to Appendix A for a list of all DDEC codes and code descriptions.

Clearing Codes With A DDR

The diagnostic codes stored in the ECM's memory can be cleared with a DDR, via the DIAGNOSTIC CODES menu. To clear the codes perform the following:

1. Press  until the SELECT DESIRED MENU appears on the screen.



2. Select ENGINE and press .

3. Press  until DIAGNOSTIC CODES is shown on the screen.

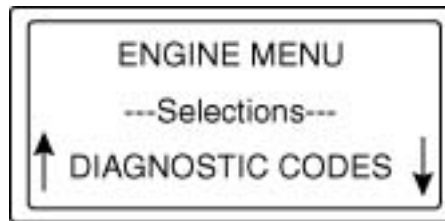

4. Then press .

5. Press  until CLEAR CODES is shown on the screen.

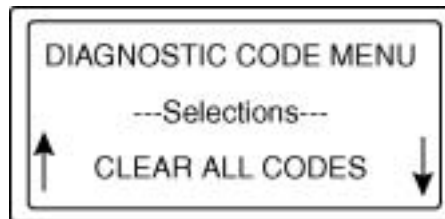

6. Then press .

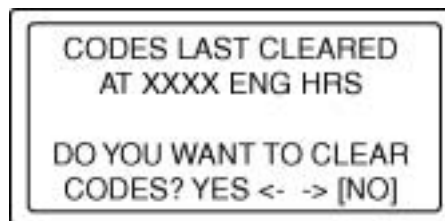



7. Use  to select YES to clear the codes.

7.3.4 VIEW CALIBRATION



Perform the following steps to view the calibration data stored within the ECM:

1. Press  until the SELECT DESIRED MENU appears on the screen.

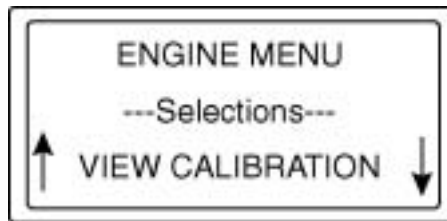

2. Select ENGINE and press .
3. Press  until VIEW CALIBRATION is shown on the screen.



4. Then Press .
5. Use  and  to scroll through the VIEW CALIBRATION menu to view the data.

The following information can be viewed with the DDR under the VIEW CALIBRATION menu:

- Engine Configuration
- Idle Shutdown
- VSG Configuration
- Engine Protection
- Cruise Control
- Progressive Shift
- ECM Input and Output
- Air Compressor
- Function Lockout

Engine Configuration

See Figure 7-4 for an Engine Configuration menu options map.

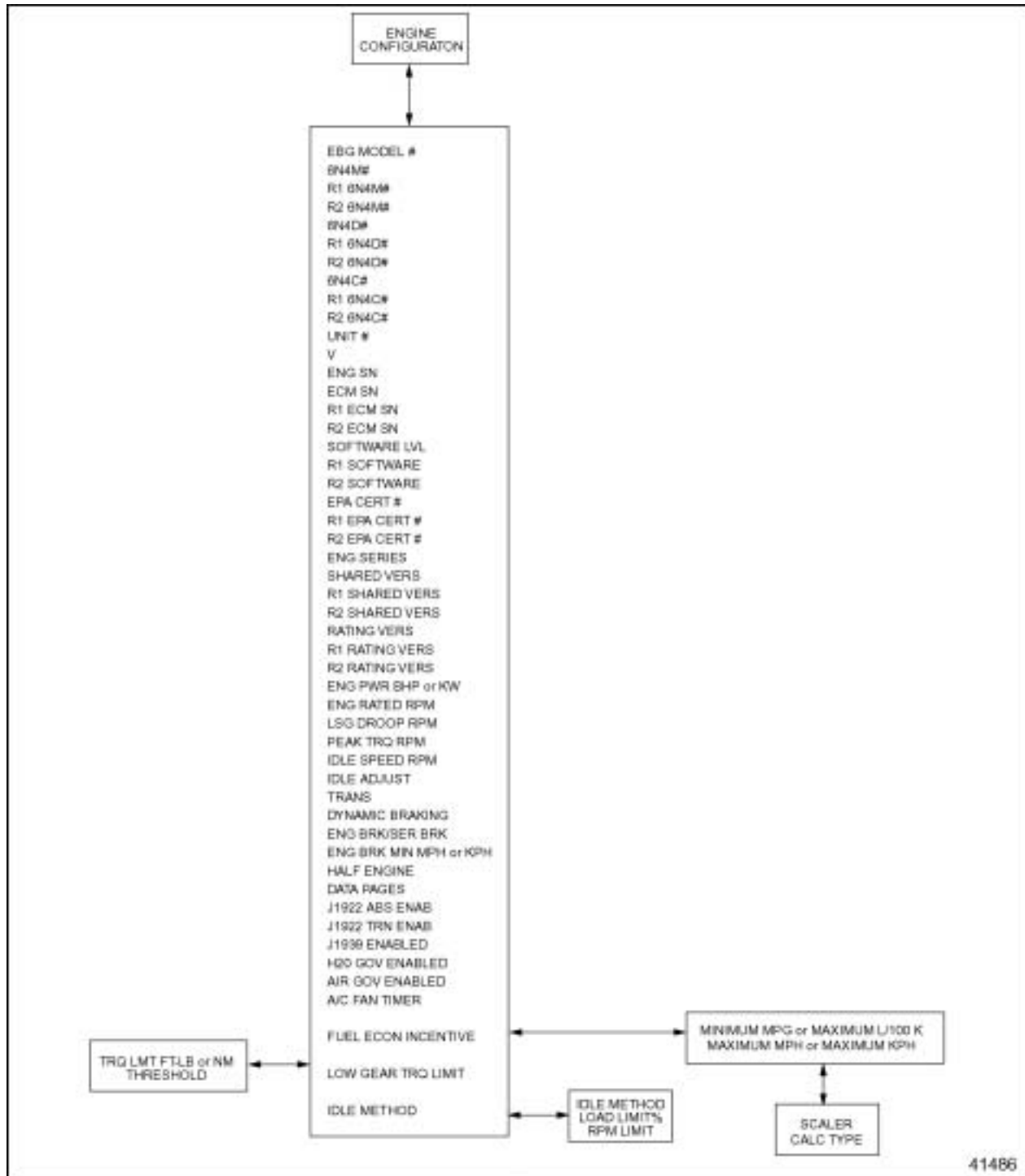



Figure 7-4 Engine Configuration Menu

7.3.5 FUEL INJECTOR



Perform the following steps to view the Fuel Injection information stored within the ECM:

1. Press  until the SELECT DESIRED MENU appears on the screen.

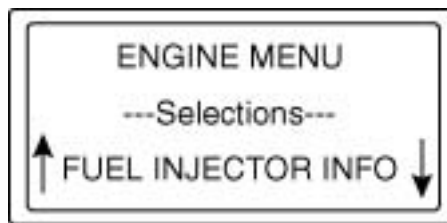

2. Select ENGINE and press .
3. Press  until FUEL INJECTOR INFO is shown on the screen.



4. Then Press .
5. Use the  and  to scroll through the FUEL INJECTOR INFO menu to view the required data or perform a function.

The following information can be viewed/modified with the DDR under the FUEL INJECTOR INFO menu:

- Cylinder Cutout
- Response Times
- Cal Update
- Change Injector Password
- Change Injector Description Option (Series 2000 and Series 4000 only)

7.3.6 ENGINE/TRIP DATA



Perform the following steps to view the Engine/Trip data stored within the ECM:

1. Press  until the SELECT DESIRED MENU appears on the screen.

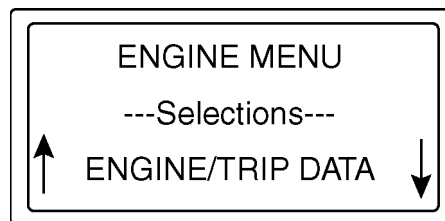

2. Select ENGINE and press .
3. Press  until ENGINE/TRIP DATA is shown on the screen.



4. Then Press .
5. Use the  and  to scroll through the ENGINE/TRIP DATA menu.

The following information can be viewed with the DDR under the ENGINE/TRIP DATA menu:

- TOTAL ENGINE DATA
- ENGINE TRIP DATA
- RESET TRIP DATA

7.3.7 CALIBRATION CHANGES



Perform the following steps to change calibration values stored within the ECM:

1. Press  until the SELECT DESIRED MENU appears on the screen.

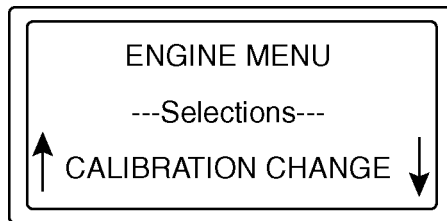

2. Select ENGINE and press .
3. Press  until CALIBRATION CHANGE is shown on the screen.



4. Then press .
5. Use  and  to scroll through the CALIBRATION CHANGE menu.

The following menus are available under CALIBRATION CHANGE:

- Reprogram Calibration
- View Calibration Change History
- Change Password

Reprogram Calibration

This selection offers a list of ECM calibrations that can be modified. See Figure 7-5.

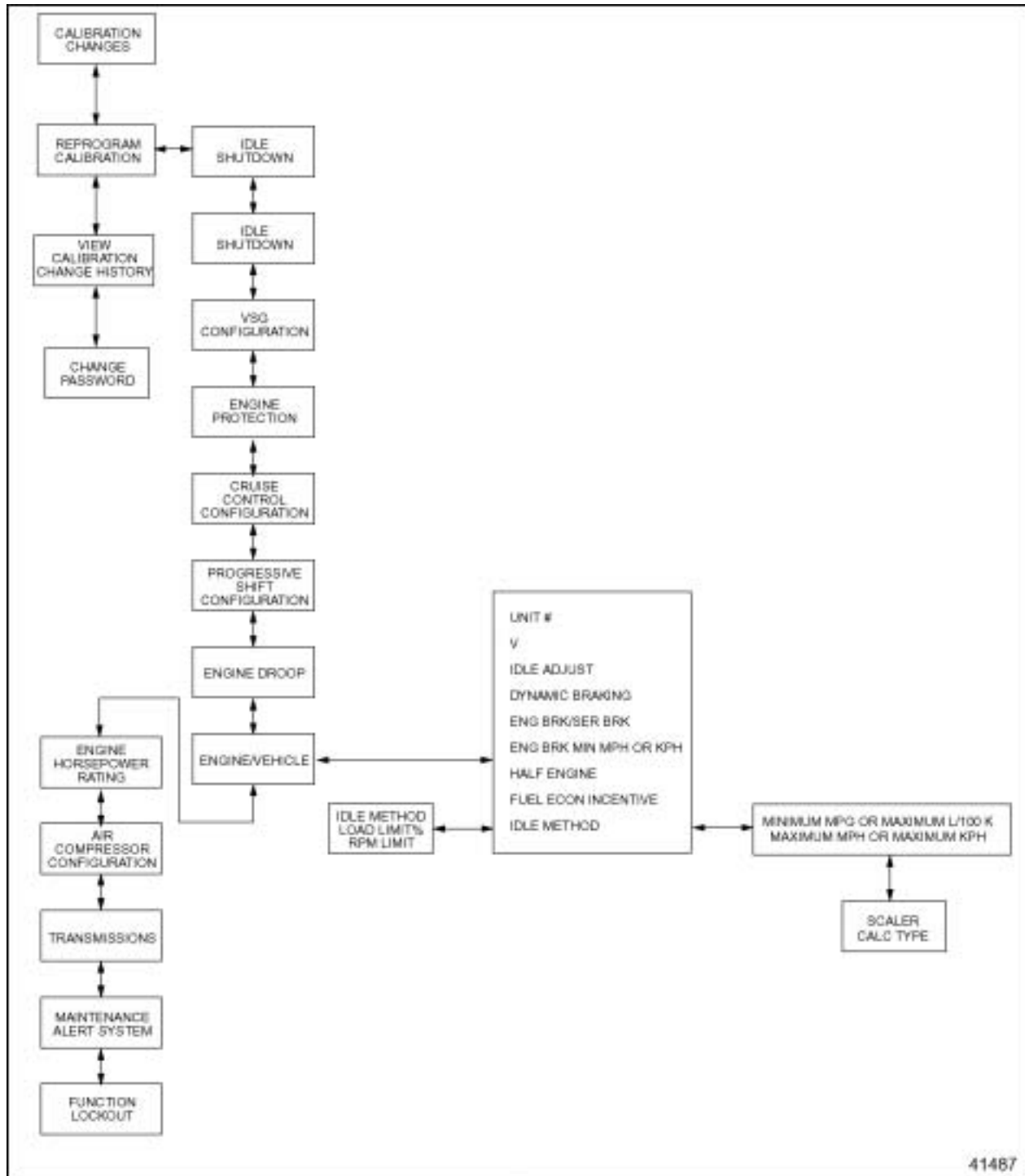
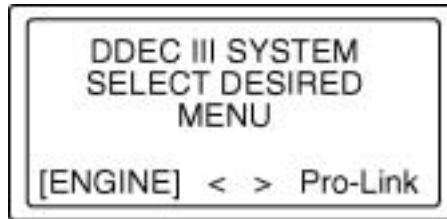

Figure 7-5 Reprogram Calibration Selections

7.3.8 SWITCH/LIGHT STATUS

Perform the following steps to view the Switch/Light status stored within the ECM:

1. Press  until the SELECT DESIRED MENU appears on the screen.



2. Select ENGINE and press .
3. Press  until SWITCH/LIGHT STATS is shown on the screen.

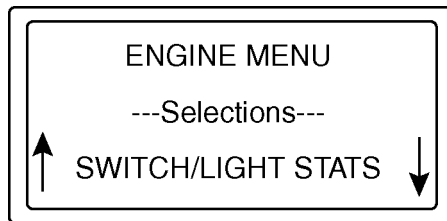

4. Then press .

The switch/light status lists the current status of each of the ECM digital inputs and outputs. This list will also display the receiver ECM #1 and receiver ECM #2 digital input and output status.

7.3.9 ACTIVATE OUTPUTS

1. Press  until the SELECT DESIRED MENU appears on the screen.



2. Select ENGINE and press .
3. Press  until ACTIVATE OUTPUTS is shown on the screen.

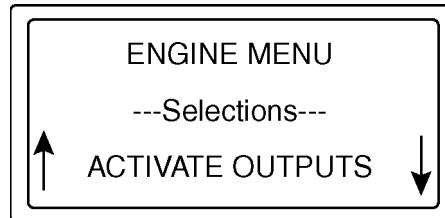

4. Then press .

The Activate Outputs menu option allows each of the digital outputs and PWM outputs to be toggled to the opposite state. This will allow testing of lights and relays to ensure proper operation.

7.3.10 MIDS RECEIVED

1. Press  until the SELECT DESIRED MENU appears on the screen.



2. Select ENGINE and press .
3. Press  until MIDS RECEIVED is shown on the screen.

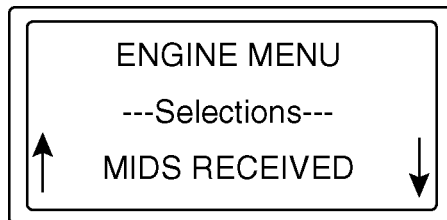

4. Then press .

The MIDS RECEIVED will display the current device that the DDR is receiving messages from as listed in Table 7-9.

Display	Description
MID 128: ENGINE	Single ECM Applications
MID 175: ENGINE R1	Dual ECM Application - first Receiver ECM
MID 183: ENGINE R2	Triple ECM Application - second Receiver ECM

Table 7-9 MIDS RECEIVED Display and Description

7.3.11 RESET COMPONENTS

This function is only available for DDEC III engines.

7.3.12 TRANSMISSIONS

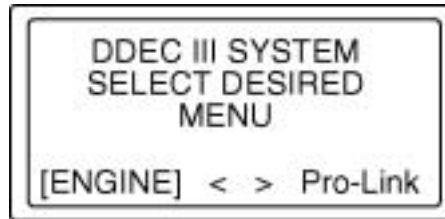

Perform the following steps to view/change the Transmission information stored within the ECM:

1. Press  until the SELECT DESIRED MENU appears on the screen.

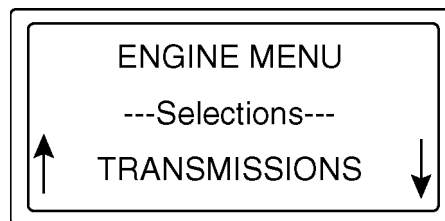

2. Select ENGINE and press .
3. Press  until TRANSMISSIONS is shown on the screen.



4. Then press .
5. Use  and  to scroll through the TRANSMISSIONS menu.

The menus are available under TRANSMISSIONS are:

- ESS TRANSMISSION
- TOP 2 TRANSMISSION

7.3.13 RESET AFR TABLE



This function is used on natural gas engines to reset the Air Fuel Ratio (AFR) Learn table.

7.3.14 MAINTENANCE STATUS

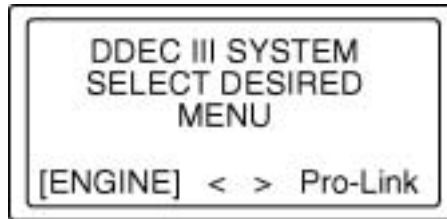

Perform the following steps to view the Maintenance Status menu:

1. Press  until the SELECT DESIRED MENU appears on the screen.

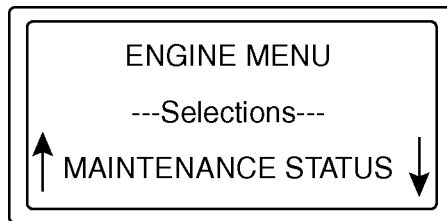

2. Select ENGINE and press .
3. Press  until MAINTENANCE STATUS is shown on the screen.



4. Then press .
5. Use  and  to scroll through the MAINTENANCE STATUS menu.

The menus are available under MAINTENANCE STATUS are:

- MAINTENANCE STATUS
- CLEAR MAINTENANCE CODES

THIS PAGE INTENTIONALLY LEFT BLANK

7.4 DETROIT DIESEL DIAGNOSTIC LINK

The Detroit Diesel Diagnostic Link™ (DDDL) is a sophisticated PC software package supporting the setting up, maintenance and repair of engines using the DDEC IV ECM. For additional information, refer to the on-line Help within the program.

7.4.1 CALIBRATION

You can use the DDDL to:

- Read and display the current calibration from an ECM.
- Create a calibration for the ECM on an individual engine.
- Save a single calibration with an ECM password so that the same calibration can be used conveniently for a fleet of vehicles with the same password, or can be used by a technician who does not have access to the password.
- Change the engine rating of a vehicle.
- Set the injector calibration when you replace the injectors.
- View an audit trail of ECM and injector calibration changes.

7.4.2 DIAGNOSTICS AND MAINTENANCE

You can use the Detroit Diesel Diagnostic Link to:

- Monitor a wide range of parameters while connected live to the ECM .
- Select a group of these parameters and plot how they have varied over the last two minutes.
- Take and save a snapshot of how the parameters vary over a period of time, so that you can replay the snapshot for detailed analysis.
- Monitor fault codes as they occur while connected live to the ECM. You can also clear any inactive fault codes stored in the ECM.
- Take a snapshot recording the fault codes occurring over a period of time, and relate their occurrence to the values of measurements made by the ECM.
- Test for the effect on performance of cutting out individual cylinders.
- View a record of the injector timings.
- Set the ECM output functions to particular values to support troubleshooting.
- Display specific troubleshooting help for any fault codes that occur, or have occurred.
- View engine and trip totals, and reset the trip counters in the ECM.
- Reset the ECM counters monitoring component usage when you replace the components.

THIS PAGE INTENTIONALLY LEFT BLANK

7.5 DDEC REPROGRAMMING SYSTEM

The DDEC Reprogramming System (DRS) is composed of Programming Software, DDECcomm Mainframe Communications software, all the hardware required to connect a Personal Computer to the ECM, and a user manual explaining the use of the software. The DRS software is used to reprogram calibrations, modify customer calibration values, upgrade ECM software versions, update injector calibration codes, and program blank ECMs. The DDECcomm software is used to communicate via modem to the DDC Mainframe computer which stores all the DDEC Calibrations.

7.5.1 REQUIREMENTS

The DRS and DDECcomm software require a Personal Computer which meets certain minimum requirements. These minimum requirements include a 80486 - 33 MHz microprocessor with 8 MB of RAM and at least 530 KB of DOS conventional memory, a modem, and the Windows 95 Operating System. DDC also sells kits which include a Laptop PC, please contact your Detroit Diesel representative for current Laptop specifications. The part numbers for the kits are listed in Table 7-10.

Kit	Part Number
DDEC Reprogramming System	MRS7500
DDEC Reprogramming System with Laptop PC	MRS7500-L

Table 7-10 Mini Reprogramming System Part Numbers

7.5.2 DRS PROGRAMMING SOFTWARE

The DRS software requires that the PC be started in the DOS mode of operation. It is not possible to reprogram an ECM by starting a DOS session from within Windows.

7.5.3 ECM PROGRAMMING MENU

There are several menu choices on the ECM Programming Menu. A menu option is selected by using the up and down arrows to highlight the choice and then pressing the space bar or the enter key to actuate it. The following sections describe these menu options.

Program ECM

Reprogram ECMs with a customer calibration that has previously been downloaded from the DDC mainframe computer. The customer configurable parameters are retained through this type of a reprogramming.

Program Fleet ECM

Reprogram fleet units from a single customer calibration that has previously been downloaded from the DDC mainframe computer. The customer configurable parameters are retained through this type of a reprogramming.

Program ECM With Mainframe Data

Reprogram ECMs with a customer calibration that has previously been downloaded from the DDC mainframe computer. Unlike the standard Program ECM option, this option will overwrite the customer configurable parameters, resulting in a calibration exactly like the one created by the factory.

Display Available ECM S/W Versions

Displays ECM software versions that are available on the PC. These versions are used to electronically upgrade ECM software for DDEC III and IV.

Display Customer Calibration

Displays electronic parameter settings currently programmed in an ECM.

Update Calibration at DDC

This function is used to store the ECM's electronic parameters on the PC. After performing this option, the Upload History function in the DDEC Mainframe Communications Program (DDECcomm) can be used to send the ECM data to the DDC mainframe computer.

Display Station Log File

Displays a file containing system usage information.

Update Customer Calibration

Similar to the Display Customer Calibration option, this option allows the electronic parameters to be updated. A customer password is required to perform this function. The following groups of information, listed in Table 7-11, can be modified.

Parameters That Can Be Updated		
Air Compressor	Output Config	VSG Configuration
Auto Cruise Resume	Idle Adjustment	Vehicle Number
CLS Polarity	Idle Shutdown	Function Lockout
Cruise Control	Rating	Lockout Password
Cruise Switch VSG	Rating Receiver #1	Fan Timer
Customer Password	Rating Receiver #2	Engine Brakes
Droop	Rating Password	ESS Config
Dynamic Braking	Progressive Shift	Half Engine Idle
Engine Protection	Transmission	TOP 2 Switch
Receiver Protection	Vehicle Spd Limiting	Fuel Quality Factor
Fire Truck	Vehicle Spd Sensor	Low Gear Torque Limiting
Fuel Econ Incentive	Vehicle ID Number	Sensor Configuration
Input Config	—	—

Table 7-11 Parameters that can be Updated with the Update Customer Calibration Option

Update Logon Parameters

This option was used to configure the communication parameters when the DOS communications package was used. The only parameter used by the Windows DDECcomm software is the Logon ID.

Upgrade ECM Software

New versions of DDEC ECM software may be programmed into customer's ECMs with this option. There is a nominal charge each time this function is performed.

Update Injector Calibration

This option displays a graphical representation of the engine allowing the injector calibration code to be updated. An injector password is required.

Display Downloaded Units

This menu item displays the Unit Numbers of the engines which have been downloaded from the mainframe and are available for programming.

Update ECM Accumulators

Update ECM with engine data such as idle hours, engine hours, cruise hours, miles, etc.

Print ECM Parameters

This menu item queries the ECM for the Customer Calibration information and formats it into a report which can be printed out on a printer attached to the parallel port on the computer.

DDC Mainframe Interface Menu

This option was used to select the DOS-based DDC Mainframe Interface Menu which loaded a separate communications program to communicate to the DDC server. This functionality has been replaced by the Windows 95 program DDECcomm which uses the quicker File Transfer Protocol to communicate with the server.

7.5.4 DDECCOMM

DDECcomm is a Win95 program which can be invoked by selecting the DDEC Server Interface icon on the Windows desktop or through the Start button via Programs | DDEC Electronic Controls | DDEC Communications. The following menu options are available in this program.

Download Engine Serial Calibration(s)

This option is used to download any changed or desired unit calibrations from the DDC mainframe computer. These calibrations are stored on the PC for a maximum of 14 days, after that period they are automatically deleted.

Download Fleet Calibration(s)

This option allows the download of a single "fleet" unit from the mainframe to the PC. This "fleet" unit calibration may be used to program multiple units in a fleet via the Program Fleet ECM option discussed above.

Upload History

This option takes the programming history on the PC and uploads it to the DDC mainframe. This allows DDC to maintain a current image of the calibration status should further service be required. The history file must first be created by running the Update Calibration at DDC menu option in the DRS Programming Software.

Display Available ECM S/W Versions

Displays ECM software versions that are available on the PC. These versions are used to electronically upgrade ECM software for DDEC III and IV.

Display Station Log File

Displays a file containing system usage information.

Display Downloaded Units

This menu item displays the Unit Numbers of the engines which have been downloaded from the mainframe and are available for programming.

Update Logon Parameters

This option is used to configure the system. All user information may be updated when this option is selected.

THIS PAGE INTENTIONALLY LEFT BLANK

7.6 DDEC ENGINE PROTECTION SIMULATION KIT

The DDEC Engine Protection Simulation Kit is used to reduce diagnostic troubleshooting time for DDEC sensors. The normal use for these false sensors is to simulate an engine fault that would result in the engine protection system triggering a code in the DDEC ECM. This kit can also be used for testing and verification of the engine shutdown system, fan control outputs, and coolant level outputs. This will also be useful in simulating an engine protection fault to show customers how the DDEC protection system will react in the event of a failure that would normally cause damage to the engine.

To use, plug the simulator into the connector currently used for the appropriate sensor. Start and run the engine and DDEC will trigger the appropriate code for that fault.

The DDEC Engine Protection Simulation Kit components and part numbers are listed in Table 7-12.

Component	Part Number
Coolant Low Level Simulator	23524785
High Oil/Coolant Temperature Simulator	23524787
Low Oil Pressure Simulator	23524786

Table 7-12 DDEC Engine Protection Simulation Kit, P/N: 23526923

The High Crankcase Pressure Simulator (P/N: 23524784) is for the Series 4000 only and is not included in kit.

7.6.1 COOLANT LEVEL LOW SIMULATOR

This simulator is preset to advise the ECM that the coolant is low. Use only for DDEC III or IV. This simulator can be used to:

- Verify protection function.
- Test low coolant level light output to ensure it is configured to the correct output and correct polarity (activates the output).
- Determine if the actual sensor is bad/shorted. A bad/shorted CLS can result in other fault codes.

7.6.2 HIGH OIL/COOLANT TEMPERATURE SIMULATOR

This simulator is preset to provide a 250°F (121°C) signal to the ECM. Use for any DDEC. This simulator can be used to:

- Test coolant temperature shutdown logic/protection.
- Test oil temperature shutdown logic/protection.
- Test coolant temperature high output.
- Test oil temperature high output.

- Fake coolant temperature high to test fan control circuit.
- Fake oil temperature high to test fan control circuit.

7.6.3 LOW OIL PRESSURE SIMULATOR

This simulator is preset to provide oil pressure signal of 0 psi (0 kPa). This simulator can be used to:

- Provide a known pressure (oil pressure) for engine protection testing.
- Provide a known pressure (fuel pressure) for fault code testing.
- Provide a known pressure (coolant pressure) for engine protection testing.
- Verify if correct output is configured for low oil pressure (activates the output).
- Test current OPS to determine if a shorted sensor is causing other codes.
- Test current FPS to determine if a shorted sensor is causing other codes.
- Test current CPS to determine if a shorted sensor is causing other codes.

7.6.4 HIGH CRANKCASE PRESSURE SIMULATOR (SERIES 4000 ONLY)

The High Crankcase Pressure Simulator (P/N: 23524784) is not included in the kit. This simulator is preset to provide a crankcase pressure signal of 12 psi / 83 kPa.

7.7 DDEC MANUALS

The following DDC manuals provide more information about troubleshooting and specific DDEC features:

- Construction & Industrial EDM and AIM Installation and Troubleshooting (7SA801)*
- Construction & Industrial EDM and AIM User Manual (6SE710)*
- ProDriver User Manual (6SE701)*
- ProDriver DC User Manual (6SE703)*
- Electronic Fire Commander Installation and Troubleshooting(6SE476)*
- Engine Synchro Shift™ Troubleshooting (6SE498)*
- Optimized Idle - DDEC III/IV - Installation and Troubleshooting(7SA741)*
- DDEC III/IV Single ECM Troubleshooting (6SE497)*
- DDEC III/IV Multi-ECM Troubleshooting (6SE496)*
- IRIS User and Installation Guide (6SE36)*
- Ether Start Installation(7SA727)*
- Data Hub User Manual (6SE704)*
- Data Hub RDI User Manual (6SE714)*

THIS PAGE INTENTIONALLY LEFT BLANK