

# **MILITARY 71-Series**

## **Battery Equalizer**

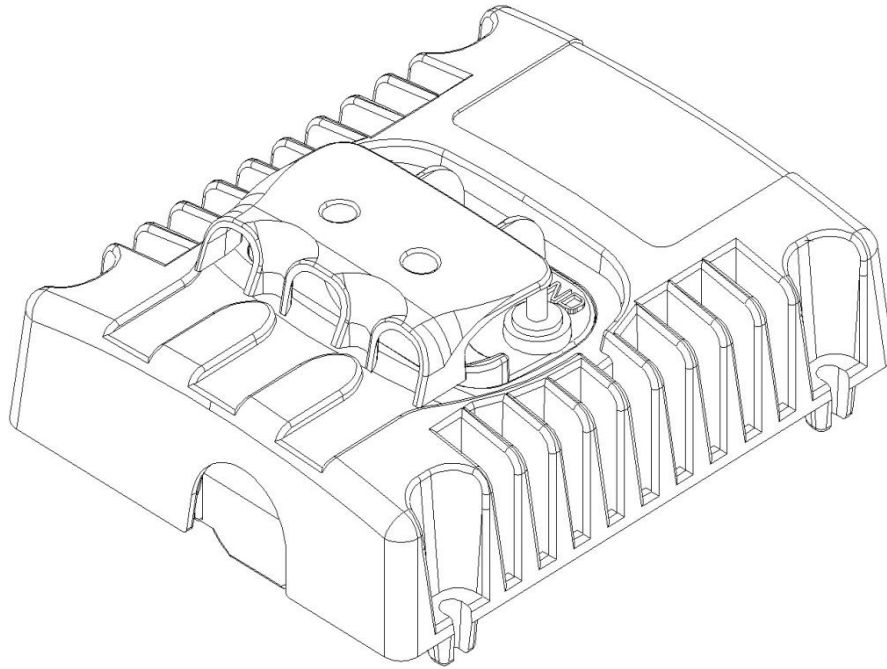

### **Table of Contents**

Introduction.....	3
Specifications.....	4
Theory of Operation.....	6
Installation Instructions.....	7

This page intentionally left blank.

## Introduction

Thank you for purchasing a Vanner *VANN-Guard Battery Equalizer*. We are confident that you will be very pleased with its performance. The 71 Series is designed and manufactured by skilled professionals using the highest standards in workmanship. With minimum maintenance and care, you can be assured of many years of trouble free service.

## General Description

The Vanner *VANN-Guard Battery Equalizer* is an efficient and highly reliable method of obtaining a 12 volt DC power source from a 24 volt DC electrical system. The equalizer makes the batteries look like they are in series and parallel at the same time. In addition to providing regulated 12 volt power, the system ensures that battery voltages remain equal which significantly extends battery life. The equalizer is designed to save your batteries and the money you would spend replacing them. Users of the Vanner battery equalizers know that it is the most cost effective and dependable solution for dual voltage systems.

A typical system would include a 24VDC power source, such as an alternator, two 12 volt battery banks in series, and the battery equalizer. The equalizer connects to the 24 volt, 12 volt and ground terminals of the battery system. When the 12 volt loads require power, the equalizer ensures that the current is taken equally from both batteries, and that the voltages of the two batteries are kept equal. This equalization ensures extended battery life and provides a stable 12 volt supply for operating accessories.

### **Paralleling equalizers:**

**Vanner Battery Equalizers may be operated in parallel to provide more power.**

**NOTE:** The Vanner *VANN-Guard Battery Equalizer* is an extremely reliable device and, when installed according to the instructions, will provide reliable operation for an indefinite period of time. However, if a system abnormality should develop that would cause an equalizer malfunction, damage to the battery system could result if 12 volt loads are present.

## Specifications

Battery Equalizer for Military Applications	
Model Number	71-100
Input Voltage 24v	18 to 36v
Efficiency (Peak)	97% See Chart 1, below.
Max 24v Input Amps	53
Output Voltage	(Input Voltage/2) ±2%
Output Amps (12v)	0-100 See Chart 2 on page 5
Standby Current	17 milliamps nominal at 28.4V
Operating Temp.	-40°C to +95°C (-40°F to 203°F) See chart below.
Storage Temp.	-54°C to +105°C (-65°F to 221°F)
Environmental Protection	Cast aluminum enclosure provides protection against salt, fungus, dust, water, fuel vapors and all fluids associated with commercial and off-highway vehicle operations. Rated IP68.
Mounting Location	Mount on a flat surface close to the batteries to allow short cable runs. Location should be protected from battery acid and gases.
Weight	11.7 lbs.

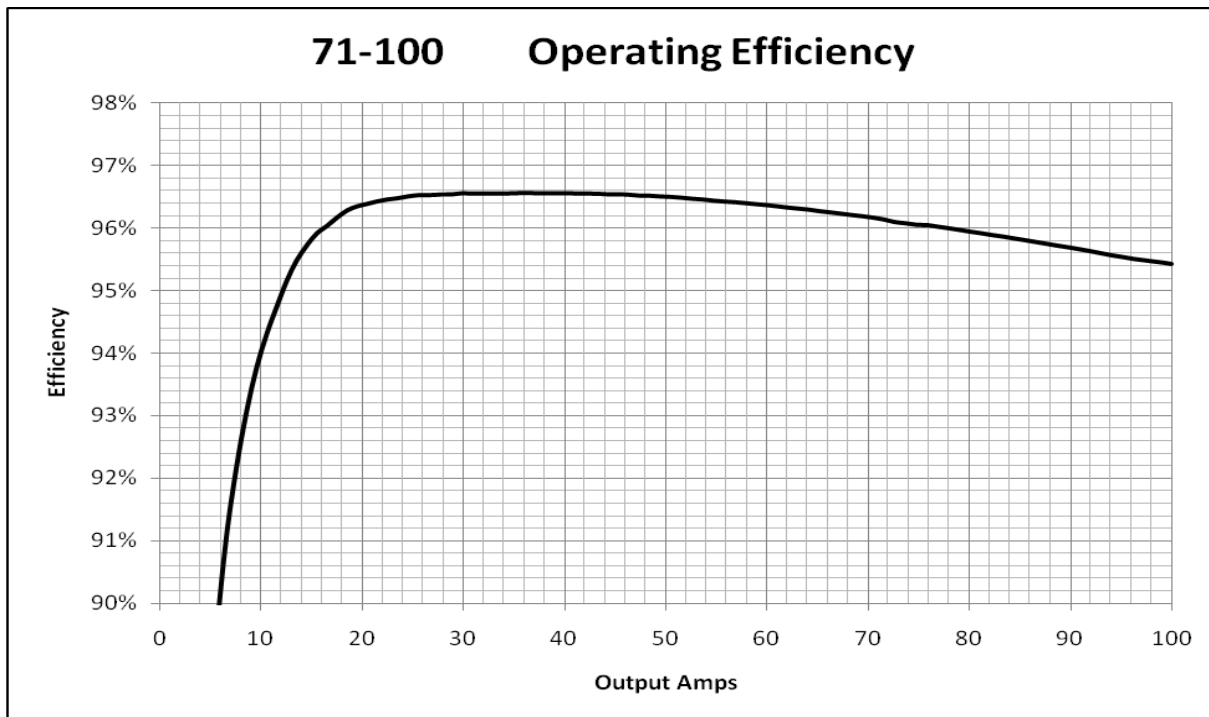

Chart 1

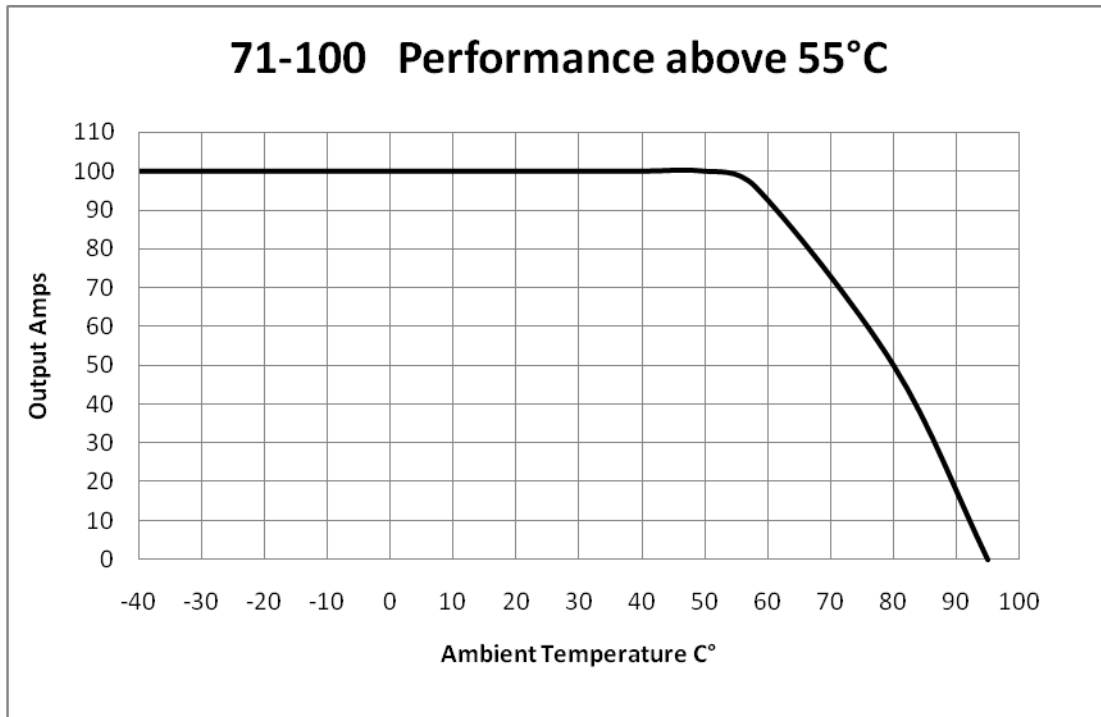
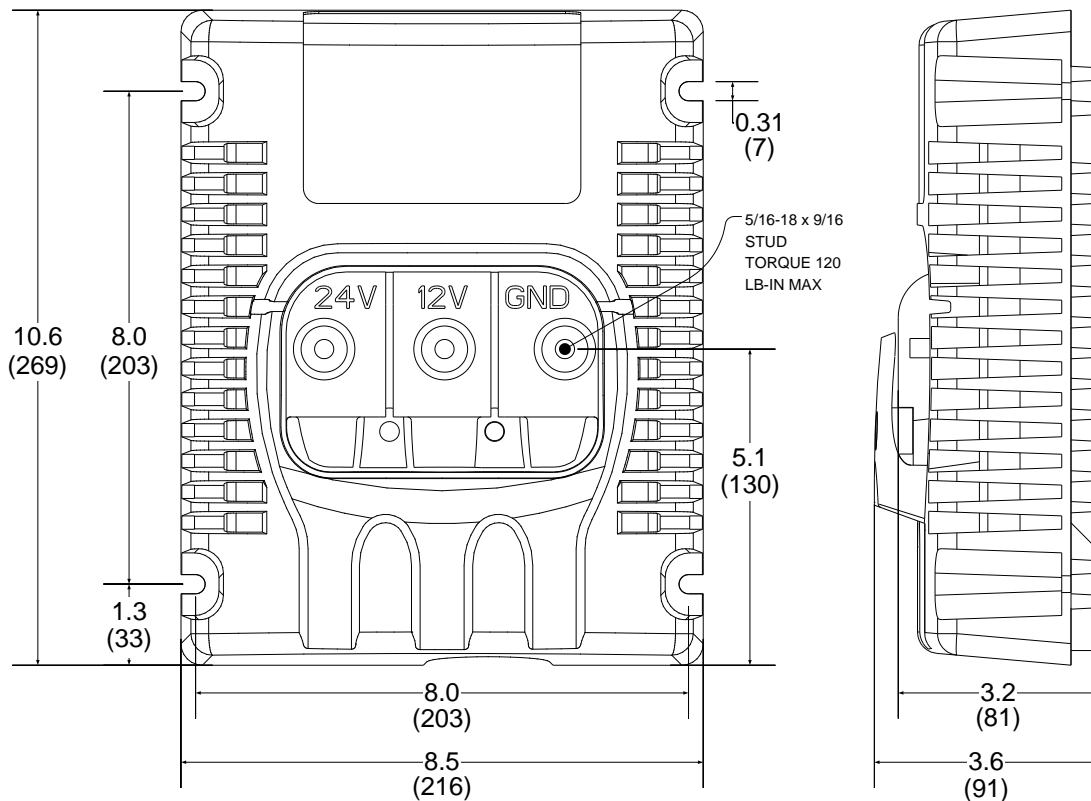
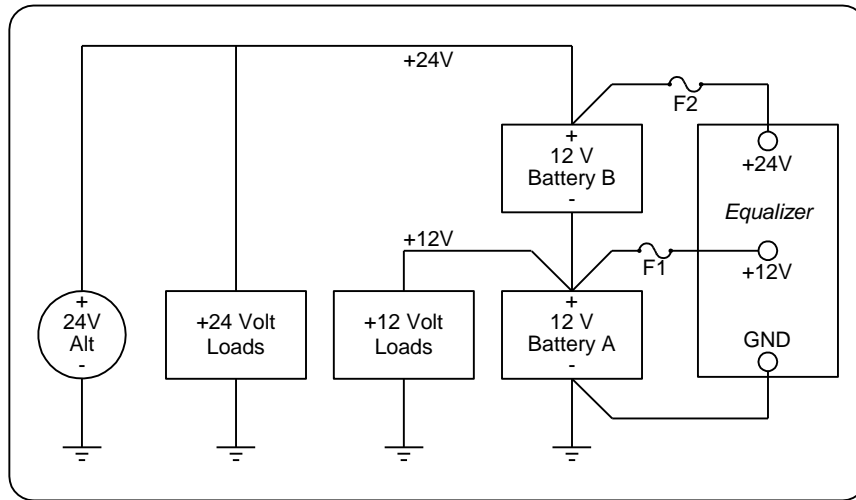

Chart 2

### 71 Series Dimensional Specifications



## Theory of Operation



In many 24 volt electrical systems it is desirable to tap into the battery system to obtain power for 12 volt loads. This method, while seemingly simple, causes a charge imbalance resulting in Battery B (see diagram) being overcharged, and possibly boiling, while Battery A discharges.

To solve this application problem the Vanner Battery Equalizer is connected to the battery system at the +24 volt, +12 volt, and ground points. The equalizer makes the batteries look like they are in series and in parallel at the same time. The equalizer maintains the voltage balance and therefore the charge acceptance rate of each battery. The equalizer will hold Battery A and B voltages to within 0.05 volts under light loads and to within 0.1 volts at full rated load.

When the voltage of Battery A is higher than or equal to Battery B the equalizer is in the standby mode, i.e., it is not transferring power from its 24 volt input to its 12 volt output. When a 12 volt load is added, and Battery A's voltage decreases to just below the voltage of Battery B, the equalizer activates and transfers sufficient current from Battery B to Battery A to satisfy the load and maintain an equal voltage and charge in both batteries.

A key advantage of a system containing an equalizer, compared to a DC to DC converter, is that if the 12 volt load requires a momentary surge current which exceeds the rated capacity of the equalizer, Battery A will supply the extra current to the load. The equalizer will then replenish the energy to Battery A after the surge has passed.

The following scenarios describe the equalizer operation.

**Scenario #1 - 24 volt load present, no 12 volt load present.** The system operates as a system would without the equalizer whether the alternator is ON or OFF. The equalizer is in standby mode except for making small adjustments to keep the batteries in balance.

**Scenario #2 - Both 24 volt and 12 volt loads present, alternator is OFF.** The equalizer will insure that both batteries will discharge at the same rate even if different loads are present.

**Scenario # 3 - Both 24 volt and 12 volt loads present, alternator is ON.** The alternator provides 24 volt power to the battery system and to the 24 volt loads. The equalizer transfers power from the 24 volt source to the 12 volt load by converting 24 volt power to 12 volts. It will supply sufficient 12 volt power to satisfy the 12 volt load and to maintain battery voltage balance.

## Installation Instructions

**Do not exceed the specified torque of 120 in-lbs.** when connecting cables to the terminal posts (+24, GND, +12) during installation of the equalizer. Torque values higher than specified may damage the product, reduce performance, and/or create hazardous conditions. Products damaged by improper torque are not covered by the warranty.

**Do not connect more than one conductor per terminal post on the equalizer.** Multiple wires and cables may overstress internal components, resulting in poor performance or creating hazardous conditions. Products damaged by the installation of multiple conductors per post are not covered by the warranty.

**Fault protection devices must be installed between the equalizer and the power source (battery).** A fault protection device would be any fuse or circuit breaker properly rated for the maximum DC current obtainable. This advisory is in accordance with SAE, NEC and UL, for mobile power applications. Install per applicable codes or within 18" of the battery. See Wire and Fuse Sizing Chart on page 9 of this manual or contact Vanner at 1-800-227-6937 or [pwrsales@vanner.com](mailto:pwrsales@vanner.com) if assistance is needed in sizing fault protection devices.

**Caution:** This equipment tends to produce arcs and sparks during installation. To prevent fire or explosion, compartments containing batteries or flammable materials must be properly ventilated. Safety goggles should always be worn when working near batteries

**Mounting Location:** The equalizer may be mounted in any orientation, on a flat mounting surface suitable to support the equalizer during operation. Do not mount in zero-clearance compartment that may result in the equalizer overheating. Locate so that contact by people is unlikely.

**Environmental Protection:** The equalizer has been designed to withstand direct exposure to rain and moisture. The has also been tested for exposure to direct pressure spray, (IP68 rating)

**Reverse Polarity Protection and Wiring Sequence:** The equalizer is internally protected against reverse polarity. If the 24v, 12v and GND wires are connected to the equalizer incorrectly, the equalizer will not be damaged and will do nothing. The wiring sequence is not an issue. The wiring sequence is not an issue. It does not matter which wire is connected first, second or last.

**Strain Relief:** The equalizer has an integral strain relief that installs onto the front of the unit. The equalizer is designed with wells for the lug to sit into to resist bolt loosening from cable movement, and the strain relief is designed to further inhibit cable movement. The diagram below shows the proper orientation for the attachment of the strain relief and the #10-32 mounting hardware that is supplied.

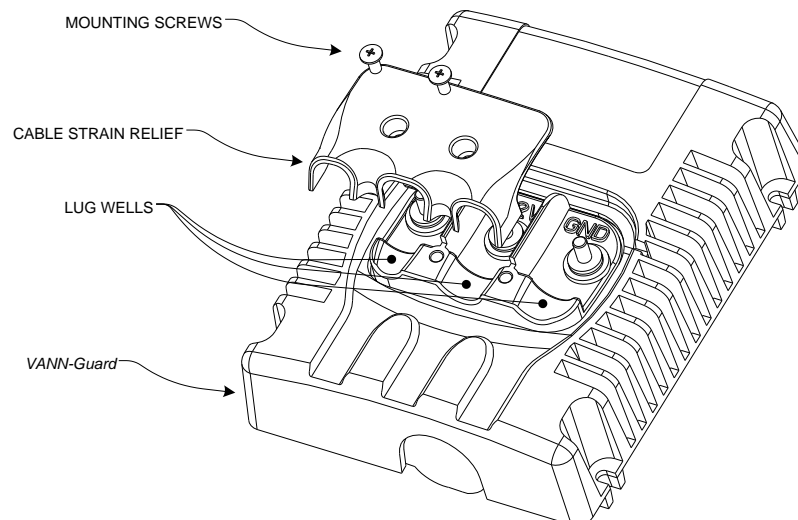

**Caution adding 12volt batteries**

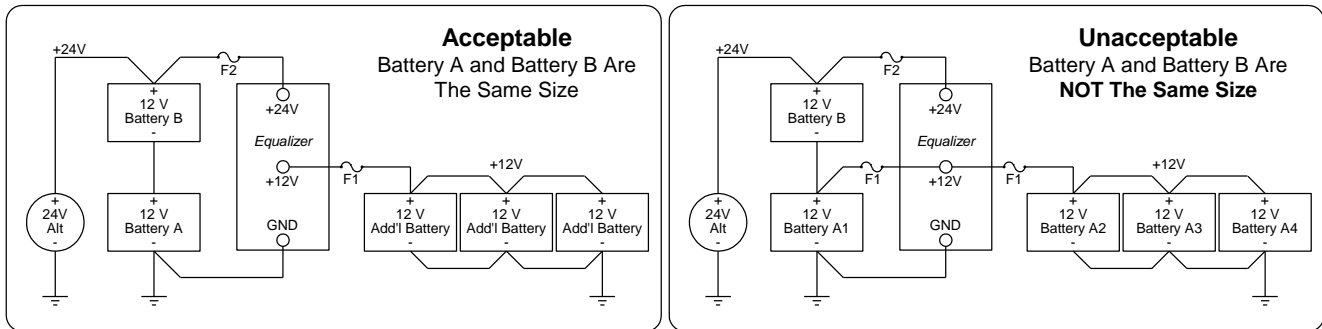

In certain applications it may be desirable to have additional 12 volt “House Batteries” to operate heavy 12 volt (inverter) loads. Use the equalizer to charge the additional batteries.

Connect the equalizer 12V terminal to the additional batteries only. Do not connect the equalizer 12V terminal to both battery banks as this would make Battery A larger than Battery B. **Damage to Battery B may occur during charging** due to overcharging, if the equalizer cannot keep up with the charging system.

**Caution using a Ground-Side Battery Disconnect Switch**

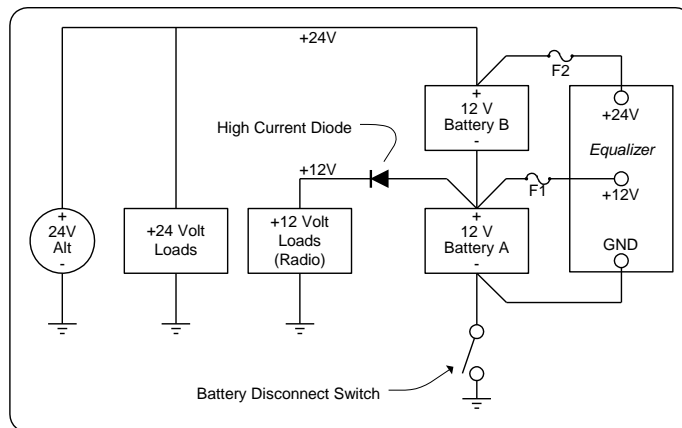

The system must be wired as shown to prevent Reverse Polarity Damage to polarity sensitive 12 volt loads while the ground-side disconnect switch is open. The equalizer GND terminal must be wired to the battery side of the ground-side disconnect switch circuit for the equalizer to work properly.

Install the external High Current Diode, such as Vanner Model 52-75 (45 amp continuous rating) to protect polarity sensitive 12 volt loads if these loads do not already contain input diode protection. This prevents a reverse polarity on the 12 volt equipment when the battery switch is open. The reverse polarity does not come from the equalizer, but from any 24 volt equipment that may be turned ON.



## Wire Size and temperature rating

Cables connecting the equalizer to the batteries must be sufficiently sized to prevent unwanted voltage drops. To properly maintain battery voltage balance, the voltage drop (loss) must be less than 0.05 VDC between the equalizer +24 volt terminal and the battery +24 volt terminal (Battery B positive terminal); less than 0.10 VDC between the equalizer +12 volt terminal and the battery +12 volt terminal (the jumper between Battery A and Battery B); and less than 0.05 VDC between the equalizer GND terminal and the battery ground terminal (Battery A negative terminal that is connected to chassis ground). In most installations, the equalizer terminals are wired directly to the battery terminals (reference fault protection) to prevent voltage loss that could occur in switch contacts, connections, and long wire runs.

**Wire and Fuse Size Chart**

Wire Size AWG	Max wire length, in feet, between equalizer and battery to keep voltage drop under 0.1 volt. The chart assumes the wire carries no other load and wire temperature is below 80°C.	
	71 Series	2 X 71 Series
#4	3.5	XXX
#2	5.2	2.6
#1	6.5	3.3
#1/0	8.3	4.1
#2/0	10.5	5.3
Fuse F1	125 amp	250 amp
Fuse F2	80 amp	150 amp

## Verify Equalizer Operation

Before testing the equalizer, be sure all battery connections are good and that fuses F1 and F2 are good.

### Equipment Required

- VoltMeter having 0.01 volt resolution. (Fluke Model 87 Multimeter recommended). (Use two multimeters if it is desirable to see the voltages of Battery A and Battery B at the same time.)
- Clamp-on amp meter (Fluke Model 36 Clamp-on Meter recommended).

The equalizer is working properly if:

1. The 12 volt DC loads are being operated continuously and are within the rated capacity of the equalizer and;
2. Battery A voltage is lower than Battery B by no more than 0.05 to 0.10 volts, measured at the equalizer's +24, +12 and GND terminals.

Vanner Incorporated  
4282 Reynolds Drive  
Hilliard, Ohio 43026

1-800-AC POWER  
(1-800-227-6937)  
Tel: 614-771-2718  
Fax: 614-771-4904

[www.vanner.com](http://www.vanner.com)  
e-mail: [pwrsales@vanner.com](mailto:pwrsales@vanner.com)

Part Number D013444-E  
December 1, 2009 Printed in U.S.A.