

FIELD MAINTENANCE MANUAL No. 4

BRAKES



Use Only Genuine TIMKEN-DETROIT Parts

**ROCKWELL-STANDARD CORPORATION
TRANSMISSION AND AXLE DIVISION
DETROIT, MICHIGAN 48232**

ROCKWELL-STANDARD CORPORATION

BRAKES

CARE AND MAINTENANCE

Different types of brake actuating systems are used. This equipment is applied by the vehicle manufacturer.

The following minimum output must be maintained for satisfactory brake operation.

MINIMUM OPERATING PRESSURES

Vacuum	18 inches
Air	85 pounds—Reservoir 60 pounds—Wheels
Hydraulic	1500 pounds/sq. in.

DRUMS

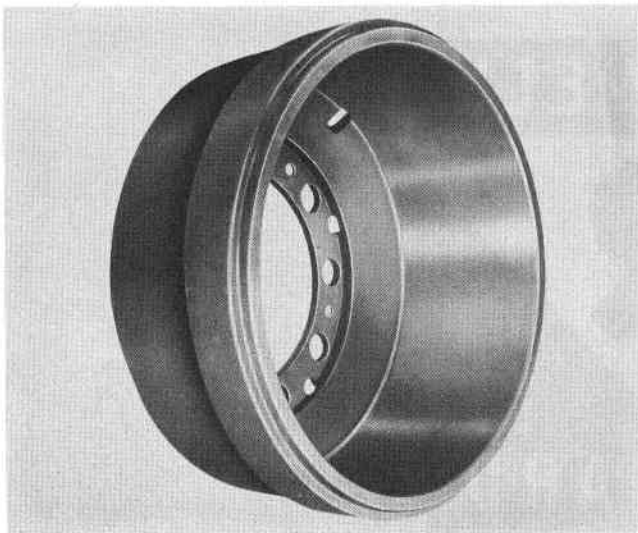

The Rockwell-Standard Brake Division does not encourage the reboring of brake drums due to the reduced strength of refaced drums. As an economy measure, in order to salvage drums, some operators do follow this practice.

On the "P" Automotive and "P" Trailer series brakes, under circumstances where refaced drums and oversize linings are used, precautions regarding cam travel should be observed to prevent sticking cams or cam "roll over." This condition prevails when the linings become worn. The service instructions relative to the use of oversize roller cam followers should be carefully followed. Drums which have been refaced should be installed on vehicles operating under the least severe conditions.

SLACK ADJUSTERS

BENDIX-WESTINGHOUSE AND MIDLAND

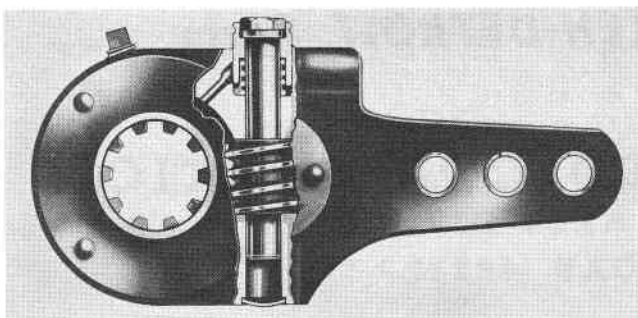

Bendix-Westinghouse and Midland levers permit 360° rotation. Later models of the B/W lever incorporate a self locking device operated by the adjusting screw wrench.

Service on these units should be obtained through the vehicle manufacturers, Bendix-Westinghouse or Midland. The Rockwell-Standard Brake Division does not supply service or parts for these assemblies.

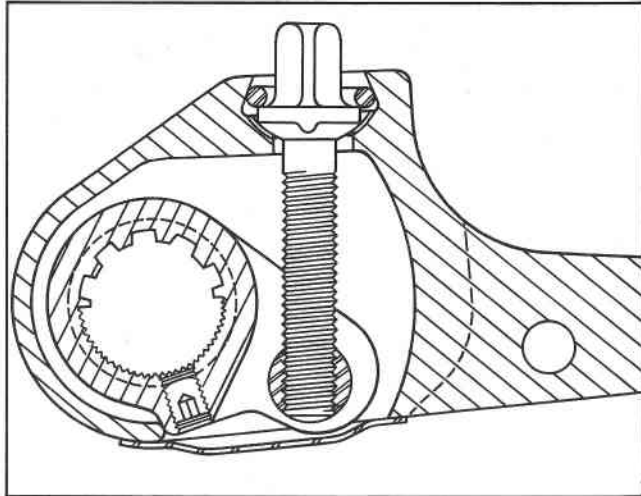

The Rockwell-Standard enclosed adjustable lever allows 69 degree rotation of the cam shaft from the initial position. This permits sufficient adjustment to compensate for approximately $\frac{5}{16}$ " lining wear. To obtain additional adjustment, the lever is moved 4 serrations or 1 spline and readjusted as required.

BRAKE DUST SHIELDS

Either a backing plate, which also serves as a dust shield, or spider is used for mounting the brake shoe assembly. Most assemblies mounted on a spider incorporate dust shields as optional equipment.

The use of dust shields should be determined by conditions encountered by the vehicle; mud, sand, dirt, water or other forms of foreign material being the governing factors. Where this condition is seasonal and maximum cooling desirable during other periods, the time of changing from summer to winter and winter to summer lubricants may be used as a guide for the installation and removal of dust shields.

The use of dust shields in this manner where conditions permit will result in the most satisfactory brake operation.

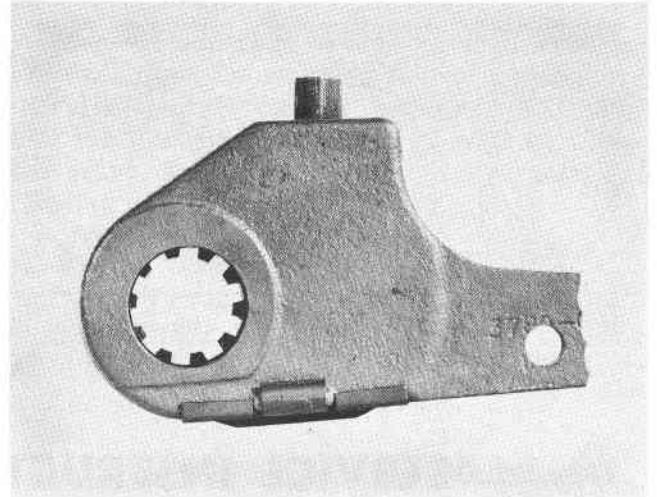
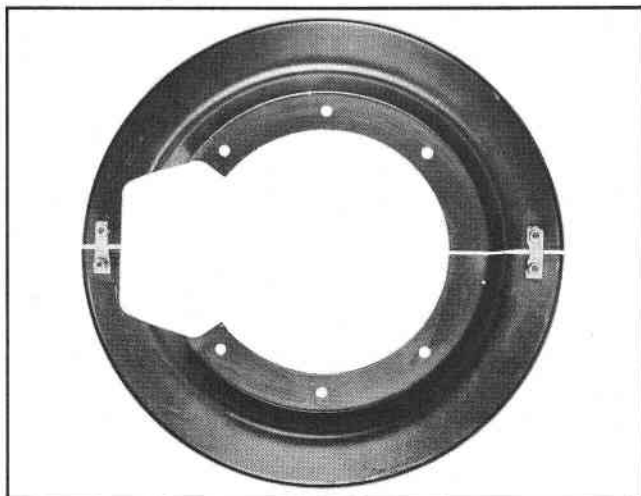

ADJUSTMENT

Adjust bolt locks at $\frac{1}{4}$ turn intervals. One notch, or $\frac{1}{4}$ turn, provides .0025" movement at the shoe center. When the adjustment limit is reached, loosen clamp bolt and remove lever. Adjust lever to original position, and move back four serrations on shaft, or one full spline. Tighten clamp bolt and adjust as required.

BRAKE LINERS

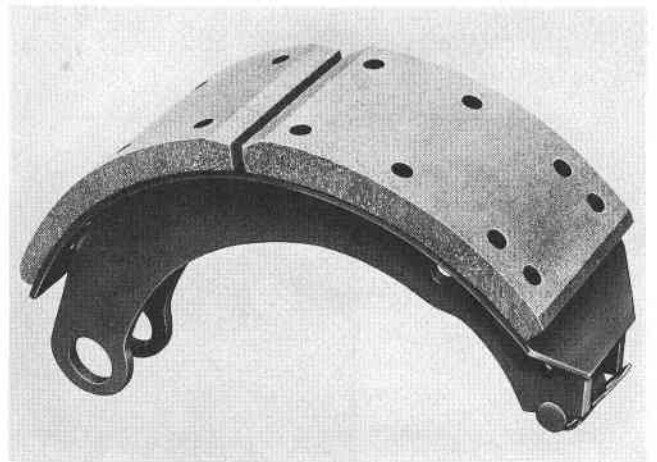

Brake liners vary considerably in both size and content. This is determined by the joint engineering departments of The Rockwell-Standard Brake Division and the vehicle manufacturer, depending on the vehicle and its prospective application. Consequently, liners should be replaced in accordance with the manufacturer's recommendations.

Combination liners with a different coefficient of friction for the forward (primary) and reverse (secondary) shoes are frequently used. On this type installation the forward blocks must be installed on the forward shoe. It should be remembered, that following the rotation of the drum, the first shoe after passing the cam or wheel cylinder is the forward shoe. Primary lining will be painted blue on the edge and the secondary, yellow.

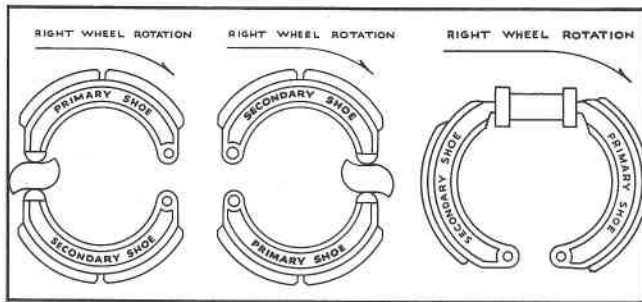

If the cam is behind the axle the top shoe is the primary and the lower shoe the secondary acting shoe.

If the cam is ahead of the axle the lower shoe is the primary acting shoe.

On hydraulic brakes of the conventional type the front shoe is the primary or forward and the rear, secondary or reverse shoe.

While riveting or bonding is the general method of attaching liners, bolting is also used for certain applications. New liners should be attached in the same manner as the original installation. All liners on a vehicle should be replaced simultaneously to obtain the most desirable results.

SERVICE INSTRUCTIONS FOR RIVETING

Liner and shoe contact faces should be clean before clamping liner in position. Rivets of the correct body diameter, head size and shape, length, and material should be used.

On the earlier pressed steel shoes rivet holes are slightly smaller than the present punched holes. It may be necessary to line drill the linings and shoes with a No. 5 drill (.2055" diameter). If replacing bonded liners with riveted liners use the No. 5 drill for new holes.

1. Clamp the lining to the brake shoe with "C" clamps so the rivet holes in both pieces are in alignment.

2. Drive the rivets squarely into the holes with a $\frac{7}{16}$ " flat head drift.
3. Make certain the lining is firmly clamped to the shoe, locating the "C" clamps as close to the rivet holes as possible.
4. Form the rivet heads with the correct tubular rivet set following the sequence shown in illustration below, working from heel to toe.

Liner installation should be checked with a .002" feeler gauge to assure liner and shoe contact.

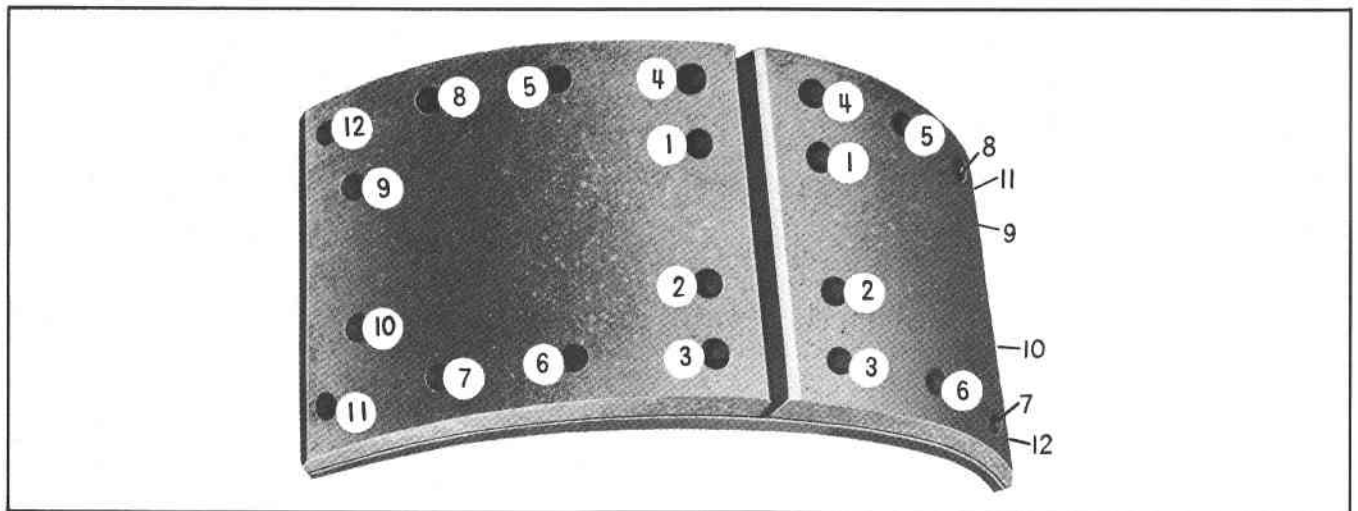

INSTALLING BOLTED LINERS

The same precaution should be taken with bolted liners as with riveted liners. New lock washers should be used and nuts tightened to 17 to 20 pound feet torque.

CIRCLE GRINDING

When liners are installed on brake assemblies not provided with adjustable anchor pins, the

liners should be circle ground to provide the correct liner and drum contact. With the cam in the full release position, the liner should be ground .070" less than the drum diameter. If 80% of the liner has not cleaned up, the cam should be adjusted and the liners ground until 80% contact of the drum diameter is obtained. The 80% contact must be continuous and in the middle of the lining.

USE OF OVERSIZE LINERS

Automotive "P" and Trailer "P" Series

To compensate for material removed when re-facing brake drums X ($\frac{1}{16}$ " oversize) and XX ($\frac{1}{8}$ " oversize) liners are furnished by the lining manufacturers. When oversize liners are used the drums should also be machined in increments of $\frac{1}{16}$ " (RADIUS increased $\frac{1}{16}$ ").

Enlarging the drum diameter will permit the cam to rotate beyond its maximum lift when the lining becomes worn. This can result in sticking cams or cam roll-over.

Cam Roll-over

To avoid this condition and obtain maximum lining wear, oversize roller cam followers, thicker wear plates or wear plate shims (depending on brake design) should be installed when the liners become approximately 50% worn.

CAST SHOE ROLLER CAM FOLLOWERS

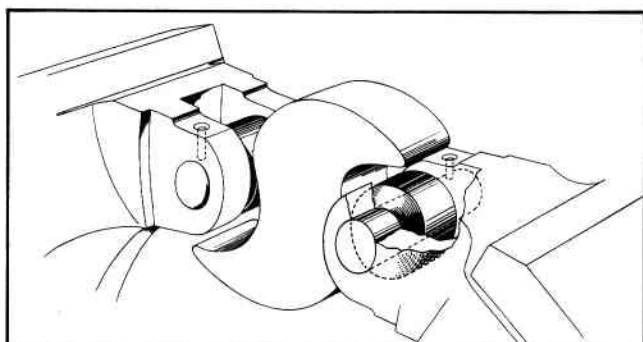

Roller cam followers are available in four sizes, each having been designed for a specific purpose.

Standard (1.250")

Standard rollers are used when installing standard lining with standard drums, "X" lining with $\frac{1}{16}$ " oversize drums and "XX" lining with $\frac{1}{8}$ " oversize drums.

If the drums were previously refaced and oversize rollers later installed, the oversize rollers must be removed and standard rollers installed.

$\frac{1}{8}$ " Oversize (1.375")

$\frac{1}{8}$ " oversize rollers are to be used with the installation of standard liners with worn or trued drums which are $\frac{1}{32}$ " oversize. $\frac{1}{8}$ " oversize rollers should be installed and the liners circle ground a few thousandths less than drum diameter.

$\frac{1}{4}$ " Oversize (1.500")

Where "X" liners have been installed with $\frac{1}{16}$ " oversize drums and standard rollers, these rollers should be removed and $\frac{1}{4}$ " oversize installed before the lining becomes worn to a point where the brake cam is no longer effective with the standard rollers.

$\frac{1}{2}$ " Oversize (1.750")

Where "XX" liners and $\frac{1}{8}$ " oversize drums have been used, the standard rollers should be removed when the liners become approximately 50% worn and $\frac{1}{2}$ " oversize rollers installed.

CAST SHOE ROLLER CAM FOLLOWERS

Part No.	Size	O.D.
1199-A-625	Standard	1.250"
1199-M-937	Plus $\frac{1}{8}$ " (.125")	1.375"
1199-Z-910*	Plus $\frac{1}{4}$ " (.250")	1.500"
1199-A-911*	Plus $\frac{1}{2}$ " (.500")	1.750"

*Install when liners are approximately 50% worn.

PRESSED SHOE ROLLER CAM FOLLOWERS

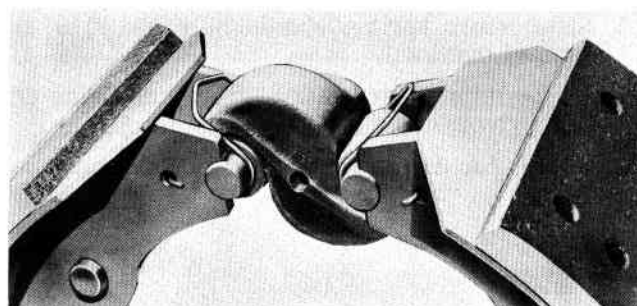

Part No.	Size	O.D.
1779-R-18	Standard	1.250"
1779-C-81	$\frac{1}{8}$ " Oversize	1.375"
1779-D-82	** $\frac{1}{4}$ " Oversize	1.500"
1779-E-83	** $\frac{1}{2}$ " Oversize	1.750"

**Install when liners are approximately 50% worn.

CAM PLATE SHIMS

When standard liners are installed with worn or trued drums, or "X" or "XX" liners have been installed and are approximately 50% worn, shims or a combination of shims should be installed under each of the cam wear plates to permit the cam to be returned to the full release position.

Thickness	Part Number
$\frac{1}{64}$ " (.015625")	2203-P-432
$\frac{1}{32}$ " (.03125")	2203-Q-433
$\frac{1}{16}$ " (.0625")	2203-R-434

PREVENTIVE MAINTENANCE

A schedule for the periodic adjustment, cleaning, inspection and lubrication of brake equipment should be established by the operator on the basis of past experience and severity of operation. Linings and drums are parts particularly subject to wear depreciation. To compensate for this wear, brakes should be adjusted as frequently as required to maintain satisfactory operation and maximum safety. Adjustments should provide uniform lining clearance, correct travel of levers and proper equalization.

Brakes should be cleaned, inspected, lubricated and adjusted each time the hubs are removed.

During a major overhaul, the following parts should be carefully checked and replaced with Genuine Replacement Parts as required:

1. Backing plates for distortion, and backing plates or spiders for looseness or sheared rivets.
2. Anchor pins for wear or misalignment.
3. Brake shoes for wear at anchor pin holes, wear pads or lever contact areas.
4. Cam shafts and cam shaft bearings or bushings for wear.
5. Shoe return springs should be replaced at the time of overhaul.
6. Brake linings for grease saturation, wear and loose rivets or bolts.
7. Drums for cracks, scoring or other damage.

Prior to reassembling, the following parts should be **LIGHTLY COATED** with brake lubricant, Specification 0-615 or the equivalent:

1. Adjustable anchor pin bearing surface.
2. Lever or shoe abutments.
3. Cam shaft needle bearings and nylon bushings.
4. Cam roller follower shafts and journals and hardened wear pads.

Excessive lubricant should be avoided as grease soaked lining cannot be salvaged or cleaned.

The use of meter type fittings which have a maximum 40 lb. pressure relief or shut off is recommended for all fittings on camshafts.

Wheel cylinders should be checked for leaks and damaged boots replaced.

It is recommended that all new lock rings be installed where used.

Wheel bearings should be properly adjusted before making brake adjustments.

Linings should not be allowed to wear to the point where rivets or bolts may contact brake drums.

Service Instructions **"DH" SERIES BRAKES**

The "DH" Brake is a dual primary brake, hydraulically actuated. This brake, commonly referred to as the Duplex Brake, features identical shoe and liner assemblies and four identical return springs which simplify assembly and disassembly.



"DH" BRAKE LAYOUT

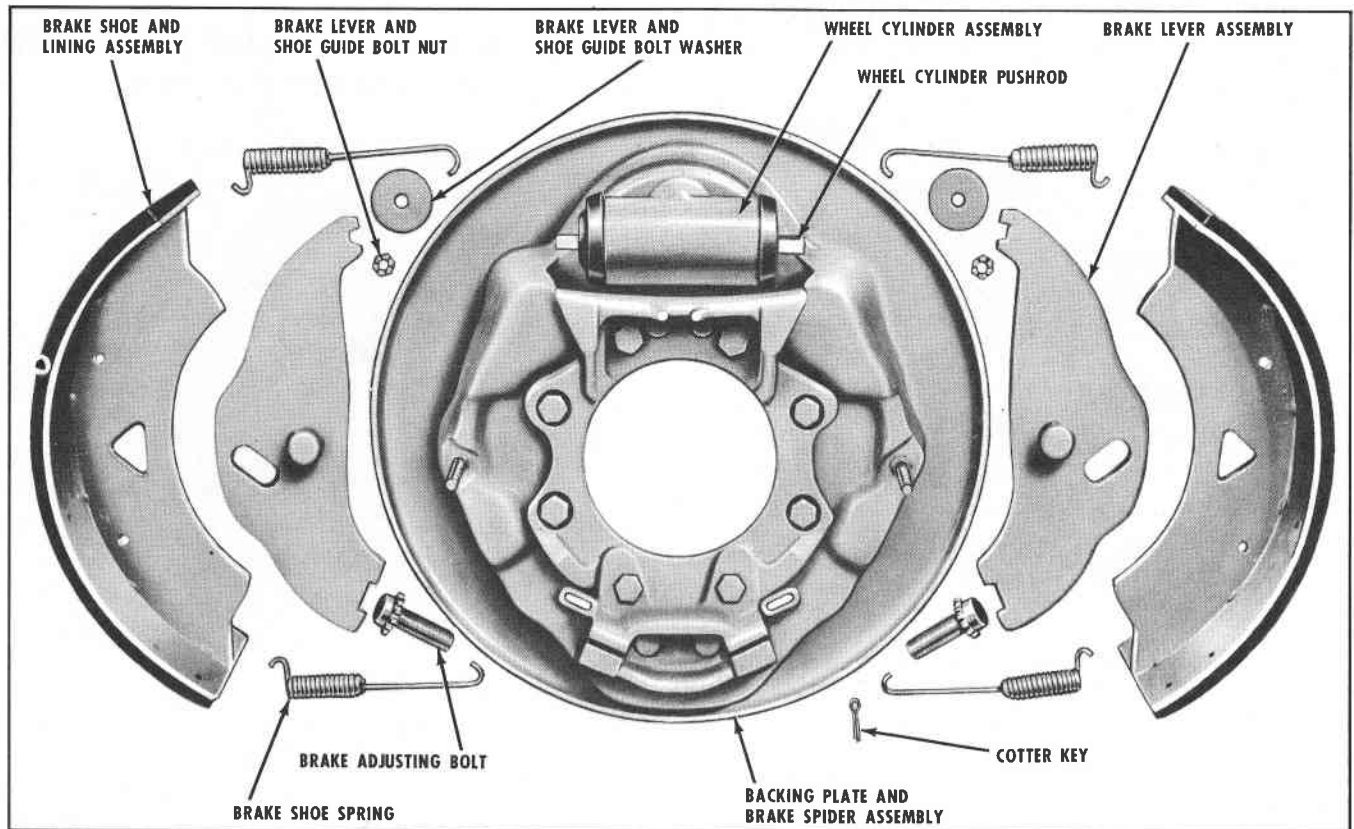

DISASSEMBLY

- A. Remove wheels and brake drums.
- B. Remove cotter key from guide bolts.
- C. Install wheel cylinder clamp to prevent forcing pistons out of wheel cylinders.

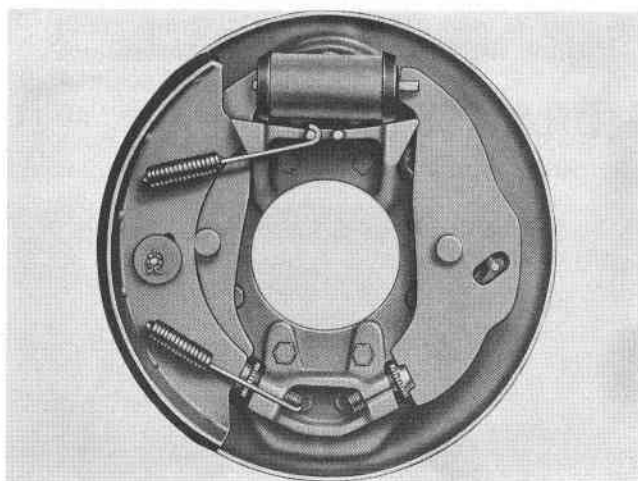

- D. Holding the shoe against the brake backing plate with one hand (after guide bolt cotter keys have been removed), remove the guide bolt nut and washer with the other hand.
- E. Allow the springs to rotate the shoe abutment end until the spring tension is released.

- F. Unhook the return springs from the spider, adjustment bolt and shoes. Remove shoes.

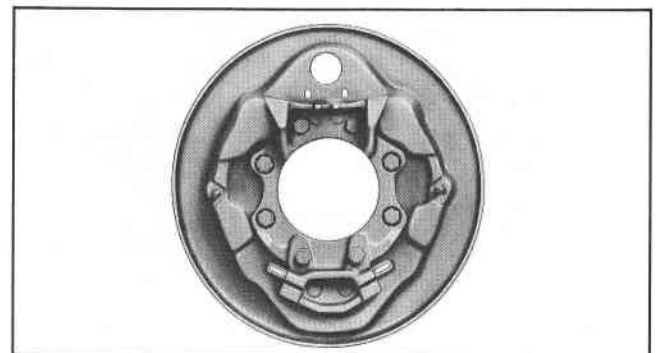

- G. For complete disassembly, disconnect the hydraulic lines, remove wheel cylinder cap screws and wheel cylinder.
- H. Remove brake adjusting bolts.

ASSEMBLY

- A. Install wheel cylinder and push rods. Tighten wheel cylinder cap screws securely.
- B. Install adjusting bolts and turn in fully.
- C. Position lever so that ends mate with pushrod at top and adjusting bolt at the bottom. (There are right and left hand levers.)
- D. Hook short ends of both springs into brake shoe web holes.

- E. Hook long end of upper spring on spider and long end of lower spring in adjusting bolt end. Lean abutment ends of shoe web against spider abutment and adjusting bolts.

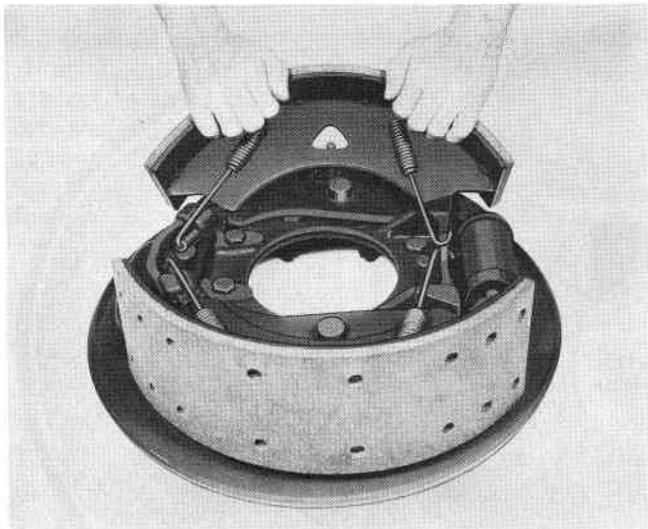

- F. With both hands rotate shoe and liner assembly over lever pressure bottom and guide bolt into position against the lever.
- G. Hold shoe and liner assembly against lever with one hand and install washer and nut on guide bolt with the other.
- H. Tighten guide bolt nut so that shoe and lever will have clearance of .015". When the spring type guide bolt washer is used, tighten the guide bolt nut until the cotter pin can be inserted in the guide pin.
- I. Lock guide bolt nut with cotter key and connect hydraulic lines.
- J. Bleed Hydraulic System after all brakes have been re-assembled.

ADJUSTMENT

- A. The "DH" Brakes are adjusted from the back-face of the backing plate at slotted holes.

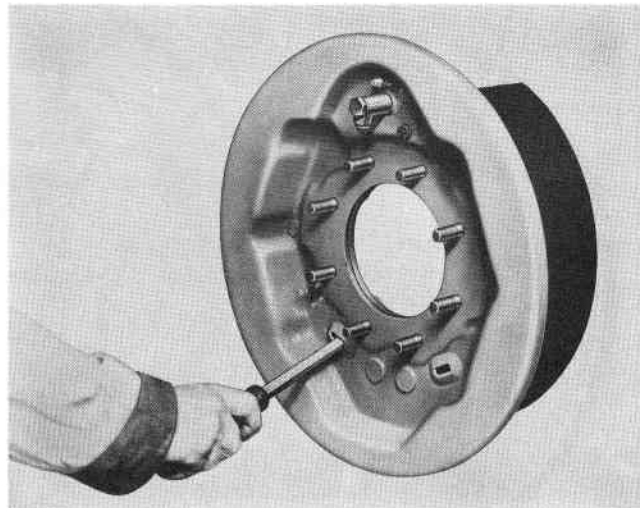

- B. Insert adjusting spoon through slotted hole to engage lugs on adjusting bolt. Move handle up or down using slot end as a fulcrum. To expand shoes move tool handle down when in the L.H. slot and move tool handle up when in the R.H. slot.
- C. Shoe liners should be brought out tight against the brake drum. Adjusting bolt should then be backed off until the drum can rotate freely. Brake shoes should be adjusted individually.

"FSH" SERIES BRAKES

The "FSH" brake is a floating shoe hydraulic brake. Actuation permits the shoes to center themselves in drum with equal effectiveness in either direction. This brake is supplied either with or without a built-in mechanical parking brake.

The "FSH" brake is also built with automatic adjustment for use on special applications. On the "FSH" automatic type, one actuation of the foot pedal sets the automatic adjustment. No further adjustment of the brake is required during the full life of the brake lining.

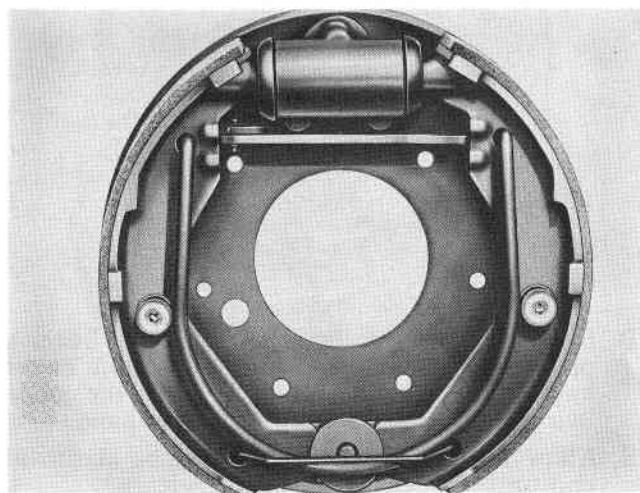

"FSH" BRAKE LAYOUT

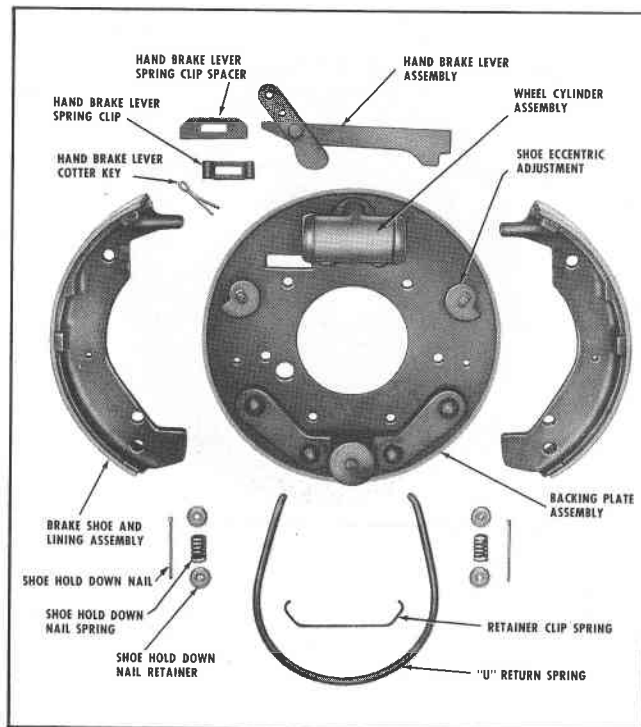

DISASSEMBLY

- A. Remove wheels and brake drums.
- B. Remove "clip spring" over "U spring" with suitable tool.
- C. Unhook and remove "U spring."
- D. Hold from turning, the "hold down nail outer spring cup" with one hand, depress spring until pliers can grip the nail. Turn nail $\frac{1}{4}$ turn and remove cup, spring and hold down nail.
- E. Remove brake shoes.
- F. On "FSH" brakes incorporating the mechanical hand brake, remove the cotter key on lever and remove spacer, clip and hand brake assembly.

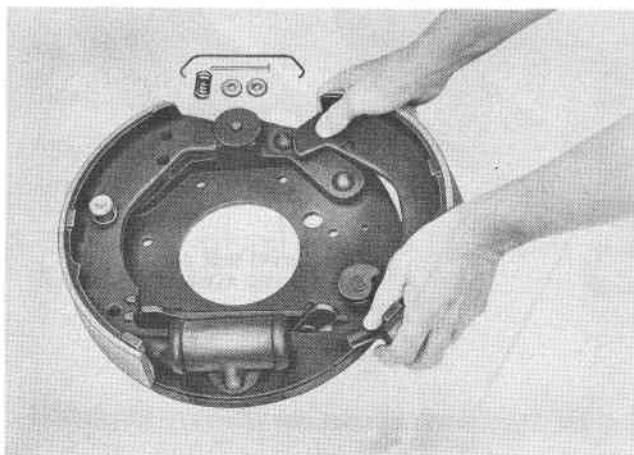

- G. For complete disassembly, disconnect hydraulic line, remove wheel cylinder attaching screw, cap screw and wheel cylinder.

ASSEMBLY

- A. Install wheel cylinder and tighten screw and cap screw securely. Connect hydraulic line.
- B. Install on units employing the mechanical hand brake, the hand brake lever assembly and insert clip, spacer and cotter key.
- C. Insert push rod end of shoe in wheel cylinder and position brake shoe.
- D. Assemble "hold down nails," cups and springs.
- E. Assemble "U spring." Place hook in one shoe and stretch spring opposite hook into the other shoe.
- F. Assemble bottom "clip spring" into shoes over "U spring."
- G. To position adjusting pawl on brakes with automatic adjustment, tap shoe in with lead hammer until brake assembly will go into drum.

ADJUSTMENT

- A. The "FSH" adjustable type brake has two eccentric cams that may be adjusted by use of a $\frac{15}{16}$ " open end wrench on adjusting bolts.

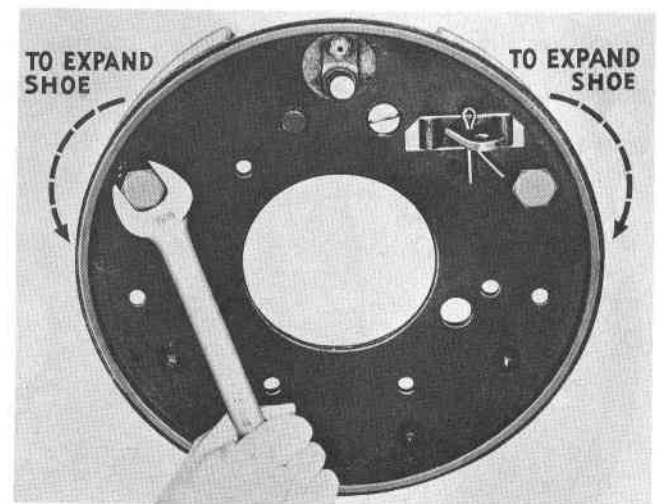

- B. Upon reassembly, first actuate brake to center shoes in drum.
- C. Adjust liners out until a slight drag can be felt while drum is in rotation. Back off adjusting bolt until drum can rotate freely.

Subsequent adjustments to compensate for lining wear may be made by moving shoe in or out by turning the eccentric cam in direction desired.

"FSH" brakes which are not equipped with the parking lever feature, usually have an upper coil spring rather than the "U" spring.

"H" SERIES BRAKES

The Hydraulic Brake commonly referred to as the plain "H" is a light duty, two shoe type brake, mounted on a backing plate which also serves as a dust shield. Adjustable anchor pins provide a means of centering the brake shoe arc in relation to the drum, and secondary or minor adjustments are made by rotating the eccentric cam which bears on the brake shoe web or pin in the shoe web.

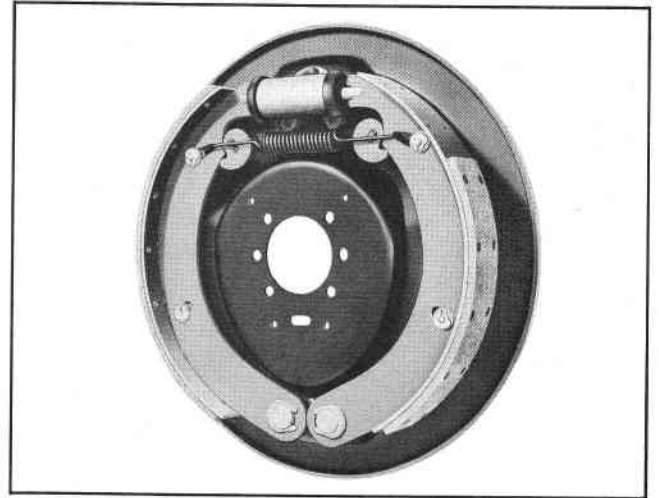

HYDRAULIC BRAKE LAYOUT

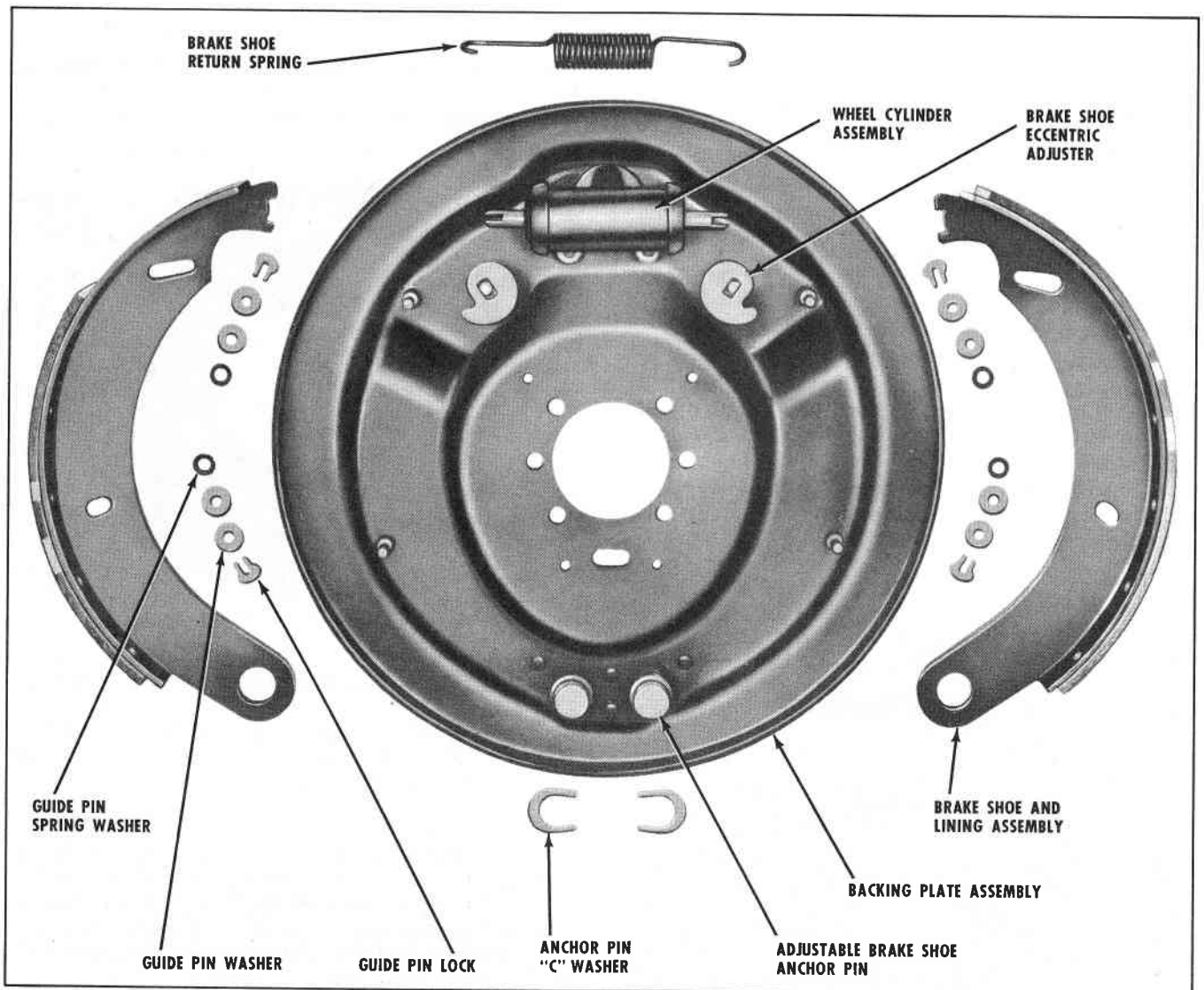

DISASSEMBLY

- A. Disconnect brake shoe return spring.
- B. Remove anchor pin "C" washers and guide pin locks and washers.

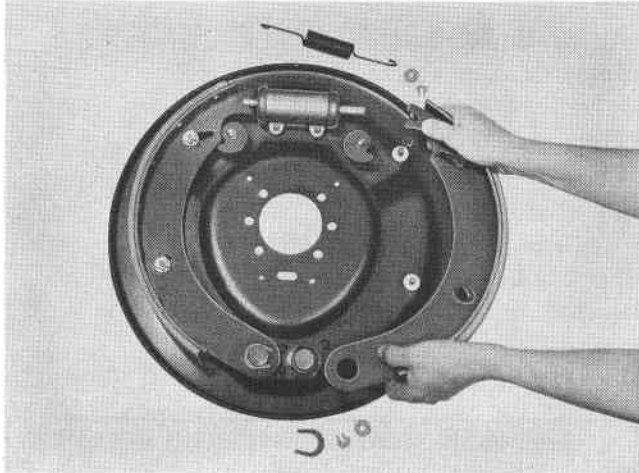

- C. Remove brake shoe and lining assemblies.
- D. Remove anchor pin lock nuts, lock washers and anchor pins.
- E. For complete disassembly remove cap screws, washers and wheel cylinder assembly and disconnect hydraulic lines.

REASSEMBLY

- A. Position wheel cylinder, install cap screws and lock washers and tighten securely. Re-connect hydraulic lines.
- B. Insert anchor pins and install washers and lock nuts. (Punch marks must be together and wrench flats in line.)
- C. Position shoe and lining assemblies and install washers and lock rings.
- D. Back off adjusting cams and position shoes on push rods in wheel cylinder.
- E. Hook shoe return spring in brake shoe web holes.

ADJUSTMENT

Following overhaul or when new linings are installed, the initial adjustment should be carefully

made to both properly locate the curvature of the lining to the drum and obtain the proper clearance.

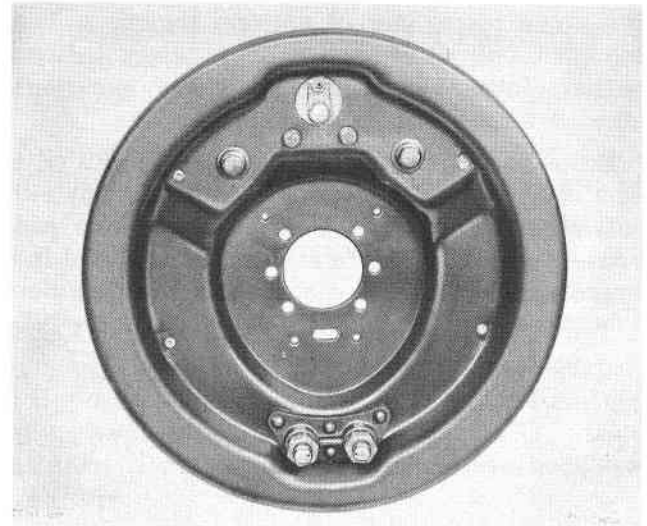

Each shoe must be adjusted to center the brake shoe arc in relation to the drum. Adjust cam to bring lining into contact with the drum and rotate anchor pin sufficiently to relieve drag. Repeat until additional rotation of anchor pin will no longer relieve drag. Lock anchor pin lock nut and back off cam sufficiently to permit wheel to turn freely.

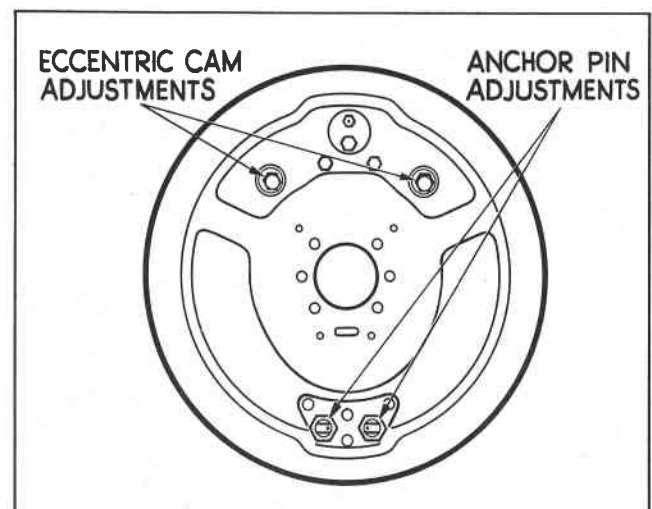

Subsequent adjustments to compensate for lining wear are made with the eccentric cam only. Turn cam to bring lining into contact with the drum. Back off sufficiently to permit free rolling drum. Repeat on opposite shoe.

"T" SERIES BRAKES

The "T" series brake is an air actuated two shoe brake, each shoe employing a one piece liner of uniform thickness. These brakes are either unit mounted with all component parts assembled on a backing plate or spider, or have inboard cam supports where operation warrants locating the air chambers toward the axle centers.

Some sizes of "T" brakes employ fabricated shoes with hardened steel cam roller followers while other sizes employ either heat treated malleable cast shoes with hardened cam follower wear pads or cam roller followers. Anchor pins of two different designs are used in various sizes of "T" series brakes. Some sizes use eccentric pins while others use fixed anchor pins.

The "T" series brakes are equipped with Rockwell-Standard enclosed adjustable levers when shoe liner thickness does not exceed $\frac{7}{16}$ ". The Rockwell-Standard enclosed adjustable lever on these will permit the maximum liner wear. "T" series brakes with thicker liners, up to and including $\frac{1}{2}$ ", are equipped with slack adjusters.

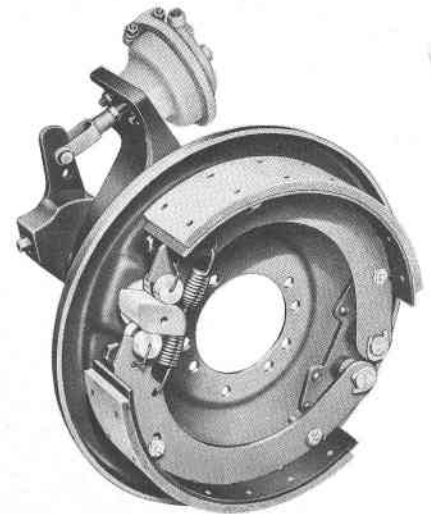

"T" BRAKE LAYOUT

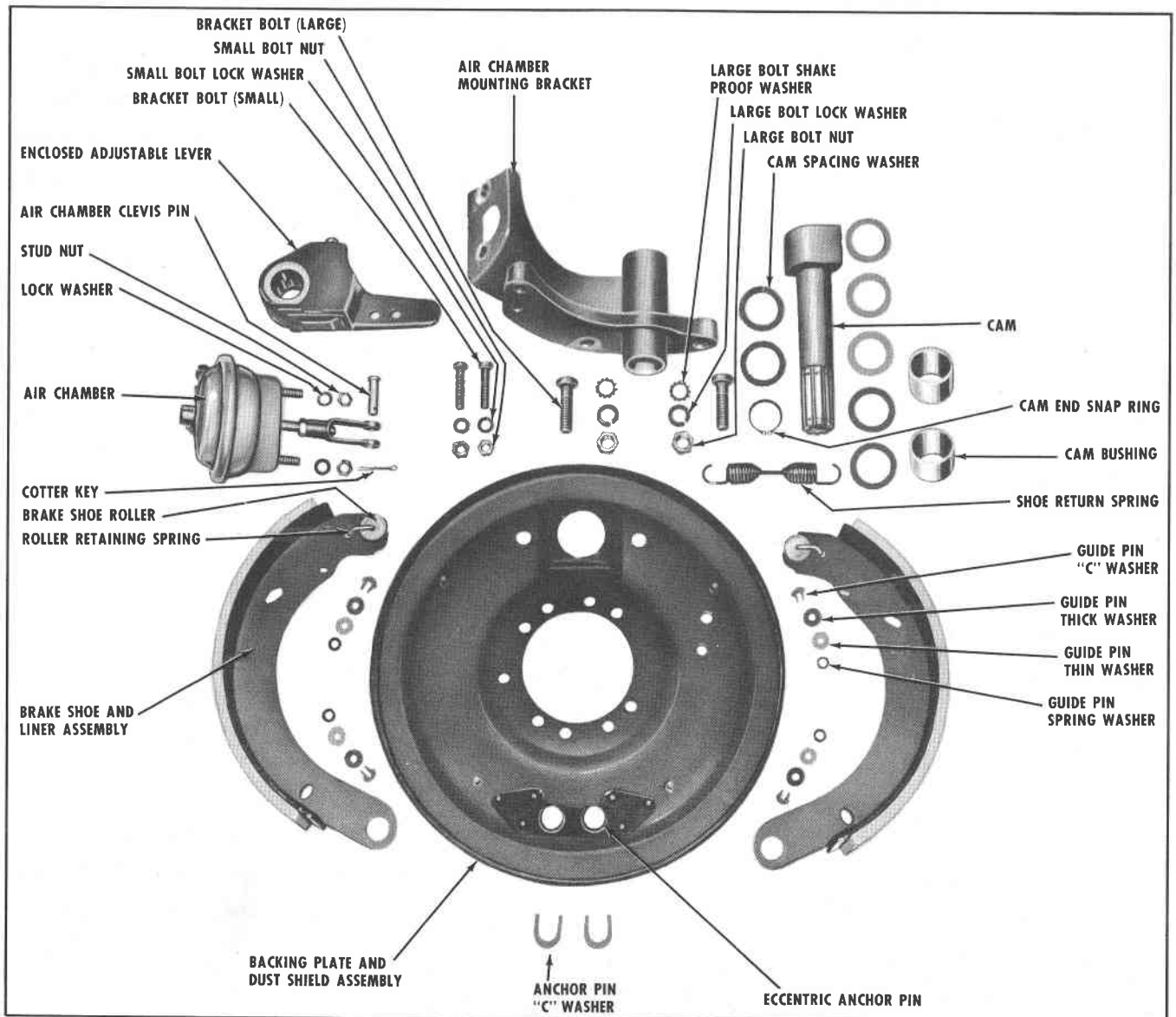

DISASSEMBLY

- A. Remove shoe return spring.
- B. Remove "C" washers from guide pins and anchor pins.

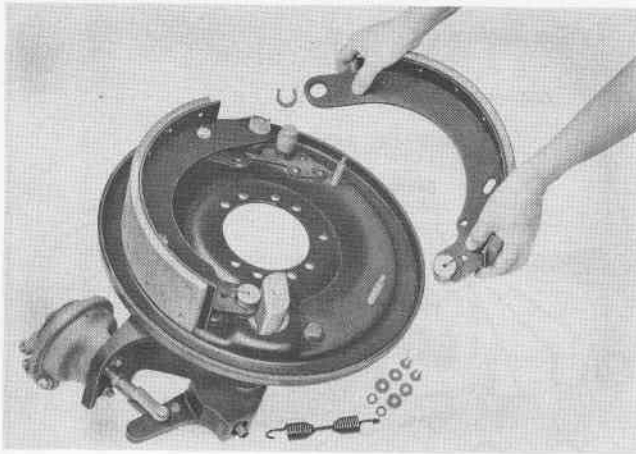

- C. Remove brake shoe and liner assemblies.
- D. Remove flat washers from guide pins.
- E. Remove brake shoe rollers and springs if necessary to replace.
- F. Disconnect cam lever assembly by removing first the spring lock, washer and the clevis pin.
- G. Remove the cam lever, cam and cam washer.
- H. Remove cam bushing only if replacement is necessary.

ASSEMBLY

- A. Install camshaft bushing if removal was made.
- B. Install cam and spacer washers.
- C. Assemble guide pin washers and position shoes over anchor pins and guide pins.
- D. Assemble guide pin and anchor pin washers and "C" washers.
- E. Hook brake shoe return spring between shoes.
- F. Install cam lever assembly and washer and secure with spring groove lock.

ADJUSTMENT

On the "T" Fabricated Steel Brake each shoe must be adjusted to center the brake shoe arc with the drum.

- A. Loosen cam bracket bolts. Apply full air. Hold air and tighten bolts. Be sure bolts are tight.
- B. Rotate both anchor pins to the full release position. (Punch marks together—wrench flats in line.)
- C. Adjust cam to bring liners in contact with drum and rotate anchor pins sufficiently to relieve drag. Repeat until additional rotation of anchor pins will no longer free drag.
- D. Tighten anchor pin lock nuts and back off cam to minimum running clearance.

To compensate for liner wear on both the "T" Fabricated Steel and the "T" Cast assemblies, adjust cam at cam lever adjusting bolt to bring liners in contact with drum and back off to minimum running clearance.

"P" SERIES BRAKES

The Automotive "P" series brake is an air actuated two shoe brake, each shoe employing two $\frac{3}{4}$ " tapered block liners. These shoes are of fabricated steel, mounted on individual anchor pins and supported by open type spiders. The air chamber mounts on a bracket that bolts directly to the spider thus making the brake completely unit mounted. Automotive "P" series brakes may also be equipped with inboard cam supports where operation or axle design requires mounting the air chambers toward the axle centers.

Dust shields are available for use when protection becomes desirable.

The "P" series brakes are actuated by the "S" type constant lift cams which are forged integrally with shaft and supported in nylon bushings. Cam pressure is applied through roller cam followers.

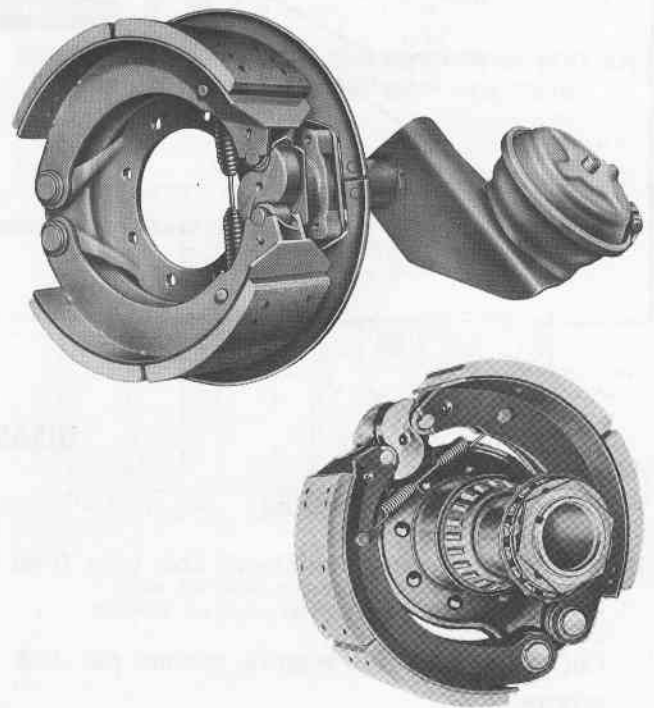

"P" BRAKE LAYOUT

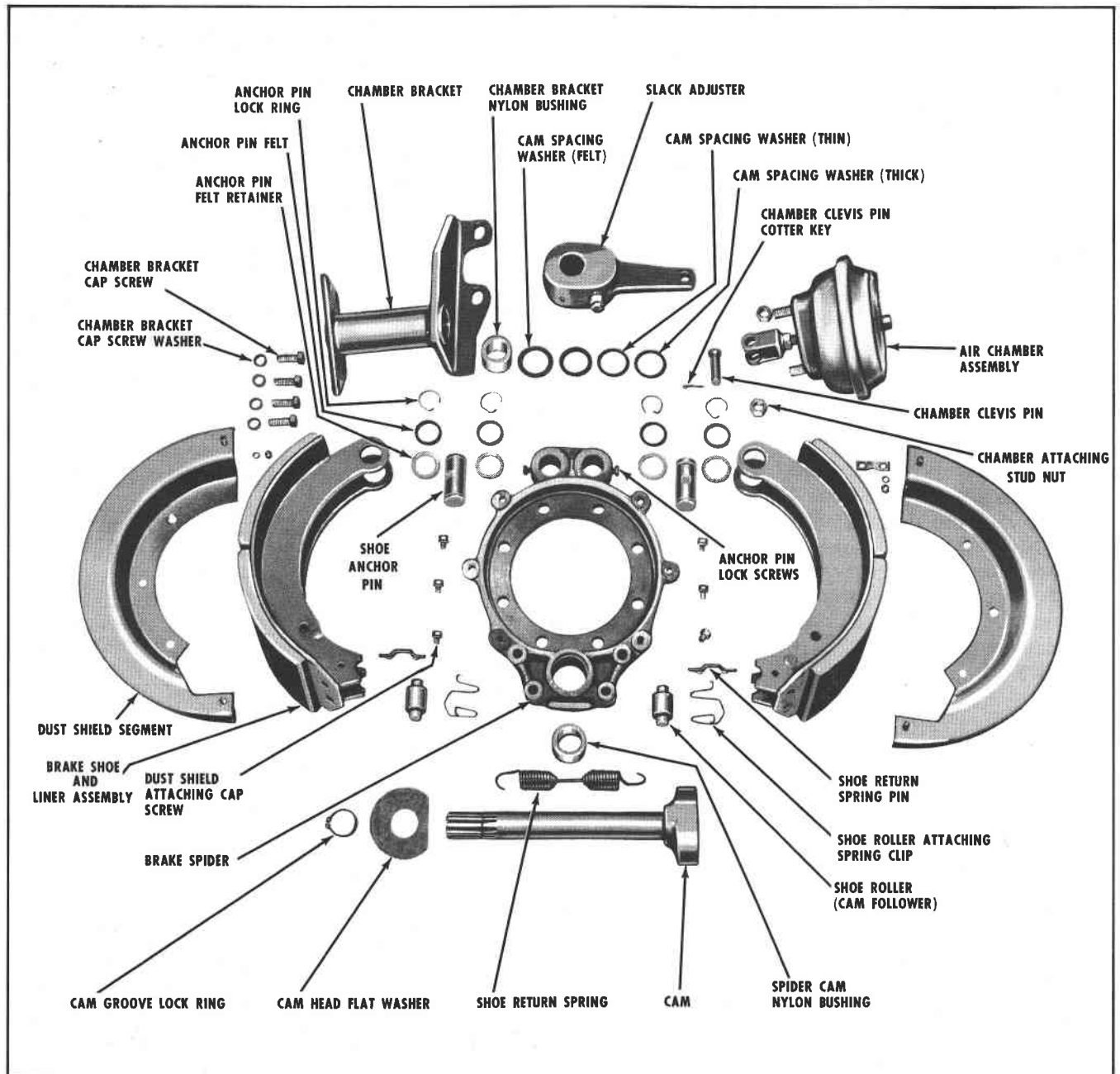

DISASSEMBLY

- A. Remove shoe return spring.
- B. Remove lock rings, retainers and felts from anchor pins.
- C. Cut lock wire and remove anchor pin lock screws.
- D. Remove anchor pins and shoe assemblies.
- E. Unhook cam follower retainer spring and remove roller cam follower.
- F. Remove cam end lock ring, washer and slack adjuster.

- G. Remove cam shaft with felt, washer for felt and large washer, from spider.
- H. Remove washers and felts from cam shaft and spider.

- I. Remove nylon bushing from spider only if replacement is necessary. See suitable tool for both the removal and installing of nylon bushings.

BUSHING REMOVAL AND INSTALLATION TOOL

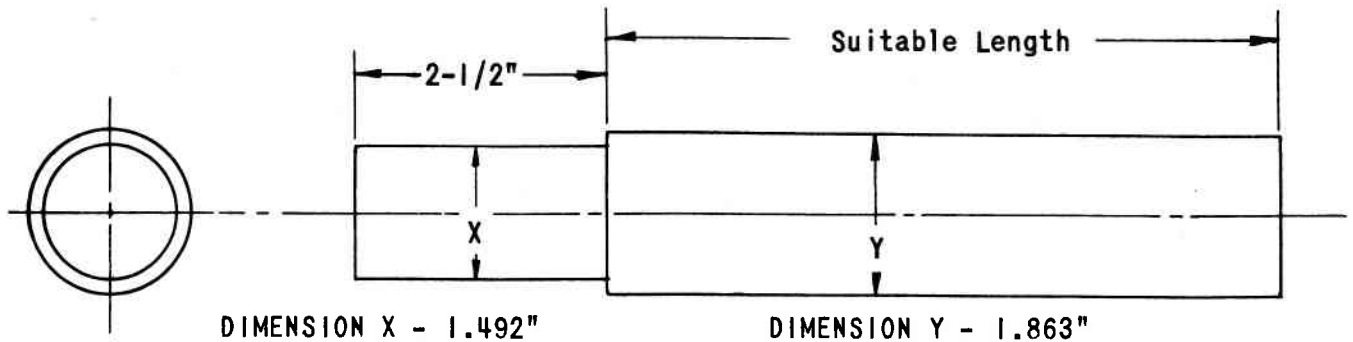

ASSEMBLY

- A. Install new nylon bushing in brake spider if required, using suitable tool.
- B. Install roller cam followers and retainer springs. See instruction relative to roller cam followers where drums have been refaced and oversize liners installed.
- C. Install large washers, felt and washer on cam end of cam shaft. Install assembly through spider and bracket.

- D. Position brake shoe assembly over spider and tap anchor pin into position with brass punch, "flat" in line with lock screw hole. See special instructions if combination lining has been used.
- E. Install lock screws, tighten securely and thread with lock wire.
- F. Position felts, retainers and install lock rings.
- G. Install shoe return spring.
- H. Install slack adjuster on splined end of cam shaft and adjust as required.

ADJUSTMENT

- A. New liners should be circle ground to .070" less than drum diameter. Adjust cam as required to obtain 80% contact.
- B. Adjust slack adjusters or levers to obtain free running clearance. When travel increases from liner wear to the maximums listed in the table below, readjust.

CORRECT POSITION OF CHAMBER PUSH-ROD AND SLACK ADJUSTER IN "OFF" POSITION

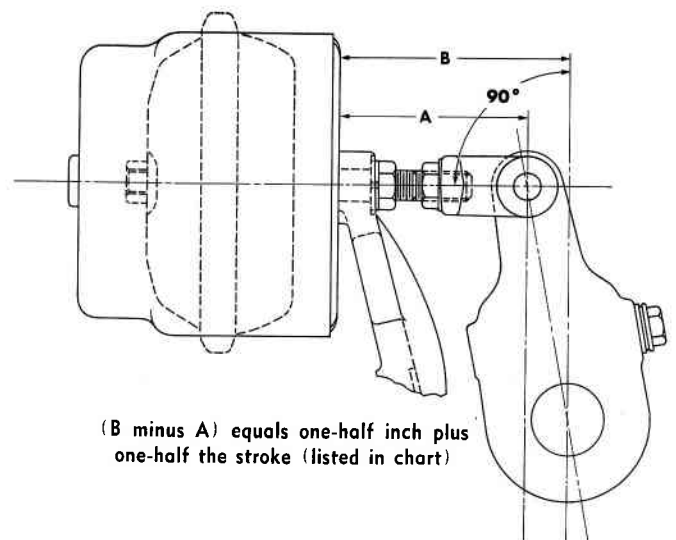

CHAMBER STROKE AT WHICH BRAKE SHOULD BE READJUSTED

Chamber Size Effective Area	"Diaphragm"	"Brake Chamber"	"Roto-chamber"
9"	1 3/8"	1 1/2"	1 1/2"
12"	1 3/8"	1 1/2"	1 1/2"
16"	1 3/4"	1 3/4"	1 7/8"
20"	—	1 3/4"	1 7/8"
24"	1 3/4"	1 3/4"	1 7/8"
30"	2"	2"	2 1/4"
36"	2 1/4"	2 1/2"	2 5/8"
50"	—	—	3"

TRAILER AXLE POWER BRAKES

The Trailer "P" series brake is a two shoe brake designed for use with power. The shoes are fabricated steel and are mounted on individual anchor pins on either replaceable open spiders or fixed open spiders.

The air chambers are mounted on brackets that are welded to the beam and inner cam supports are adjustable for cam shaft alignment.

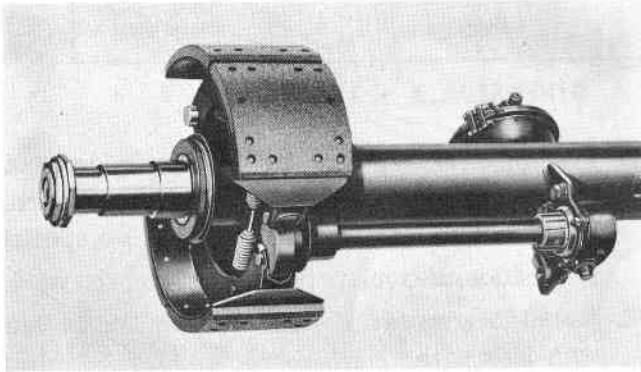

DISASSEMBLY

- A. Remove shoe return spring.
- B. Remove lock ring, retainer and felt from anchor pin if employed.
- C. Cut lock wire and remove anchor pin lock screw or drive out locking pin.
- D. Tap out anchor pin and remove shoe assembly.
- E. Unhook shoe web retainer spring and remove roller cam follower.
- F. Remove inner cam end lock ring, washer and slack adjuster.
- G. Remove washers and felts from cam shaft and spider.
- H. Remove nylon bushing from spider only if replacement is necessary.
- I. If inner cam end nylon bushing is to be replaced remove bolts and separate adjustable support bracket and remove the bushing.

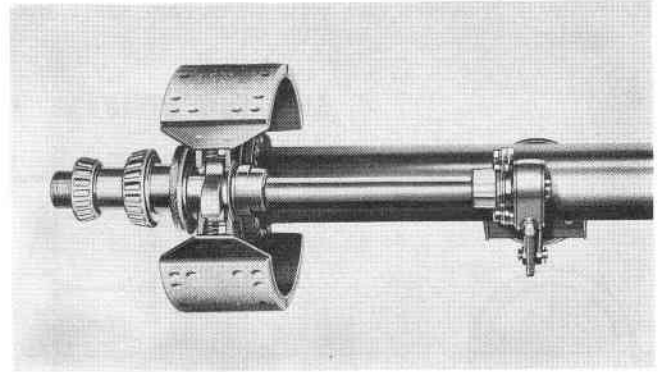

Trailer brake shoe anchor pins (depending on model) may be either the stationary type secured by use of spider set screws or the free rolling type held in place by a locking pin. The brakes are actuated by the "S" type constant lift cams which are forged integrally with the shaft and supported in nylon bushings at both inner and outer ends. Cam pressure is applied through roller cam followers.

A suitable punch for the removal of these locking pins may be made from a 5" rod $\frac{9}{32}$ " in diameter by turning or grinding one end to $\frac{3}{16}$ " diameter $\frac{1}{8}$ " long. This smaller end will pilot in the pin and prevent punch from slipping. See illustration of suitable punch below.

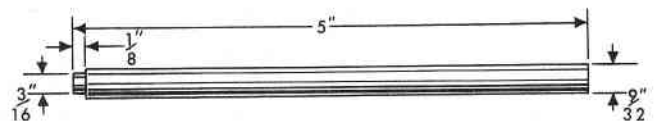
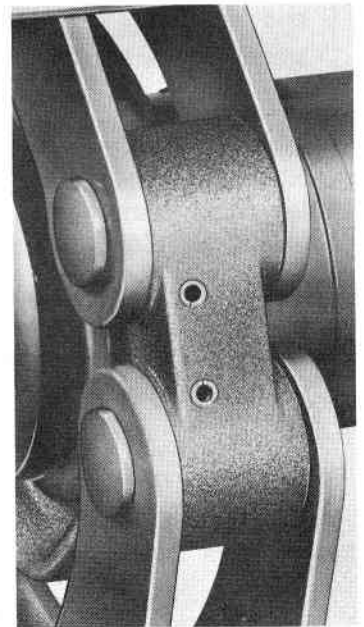

ASSEMBLY

- A. Install the spider (outer) nylon bushing, felts and retainers first if (outer) nylon bushing has been replaced.
- B. Loosely assemble the camshaft inner nylon bushing retainers to the nylon bushing and then loosely attach the retainers and nylon bushing assembly to the housing bracket.
- C. Lubricate the inner surfaces of both the (outer) nylon and (inner) nylon bushing.
- D. Install camshaft with large flat washer into spider and nylon bushing assembly. When end of camshaft clears bushing assembly install lock ring on camshaft and proceed with shaft into and through the inner nylon bushing.
- E. Slide lock ring over shaft and secure into groove next to spider.
- F. Align the parts and carefully tighten the retainers around the nylon bushing, then tighten the retainer and bushing.
- G. Position "S" cam at zero and install slack adjuster, washer and lock ring.
- H. Attach roller cam follower to brake shoe web with retainer spring.
- I. Assemble brake shoe assembly to spider and tap anchor pin in place.
- J. Secure anchor pin with lock screw and lock wire or locking pin depending on type employed.
- K. Install felts, retainers and lock rings if employed.
- L. Install shoe return spring.

ADJUSTMENT

Follow adjustment procedure as outlined under "P" Brake section, located on bottom of page 14.

ROCKWELL—STANDARD HEAVY DUTY "P" SERIES BRAKES

The HEAVY DUTY "P" series brake is an air actuated two shoe brake designed for heavy duty and special equipment where greater shoe and drum areas are necessary. This heavy duty series ranges in diameter from 18" to 22" and in width from 4" to 7".

The shoes are of heat treated malleable castings mounted on open spiders by individual anchor pins. Each shoe has hardened cam pressure pads and employs two 3/4" tapered block liners.

The camshaft and air chamber support bracket is mounted directly on the brake spider making the assembly complete as a unit, however the heavy duty brake may also be equipped with inboard cam supports where operation or axle design requires mounting the air chambers toward the axle centers.

On these HEAVY DUTY brakes, cam pressure is applied to the shoe hardened wear pads through the double "S" cam which is supported in needle bearings.

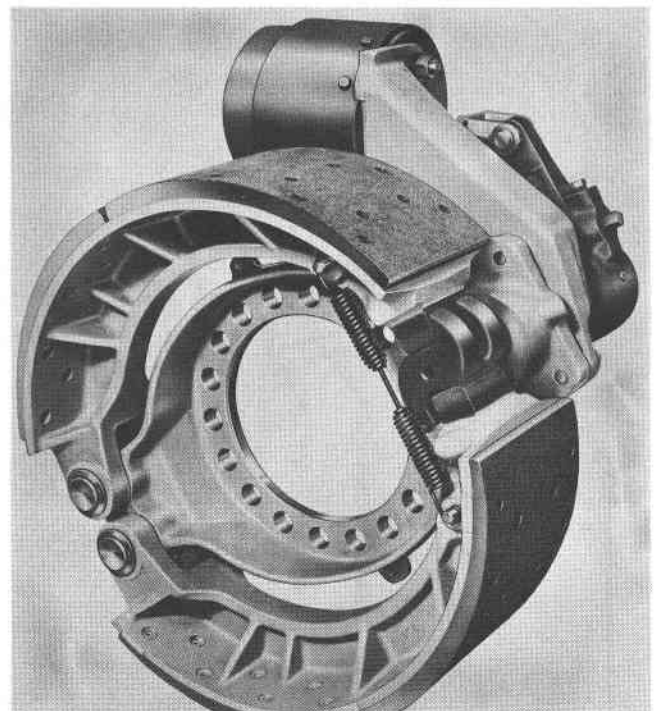

HEAVY DUTY "P" BRAKE LAYOUT

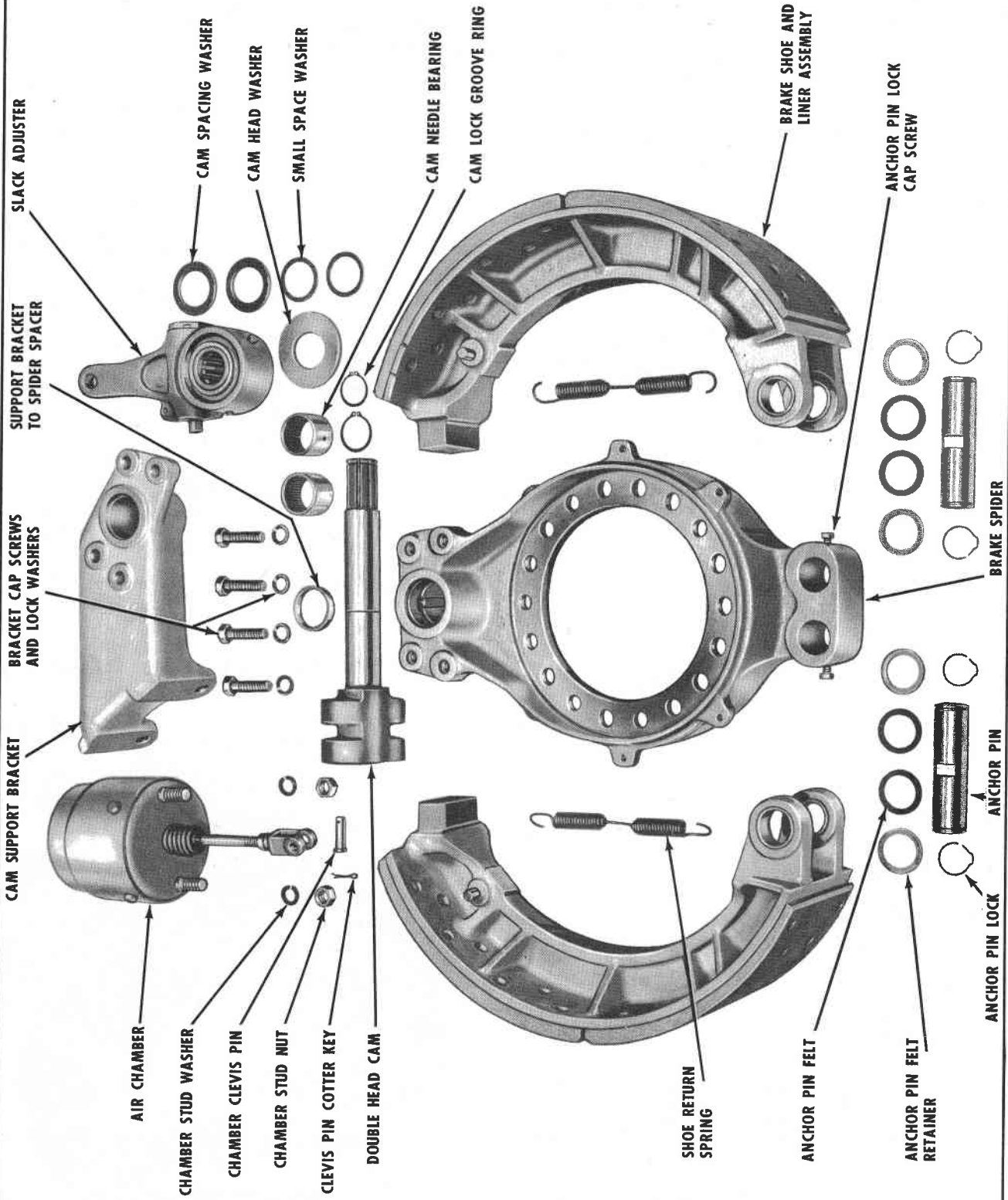

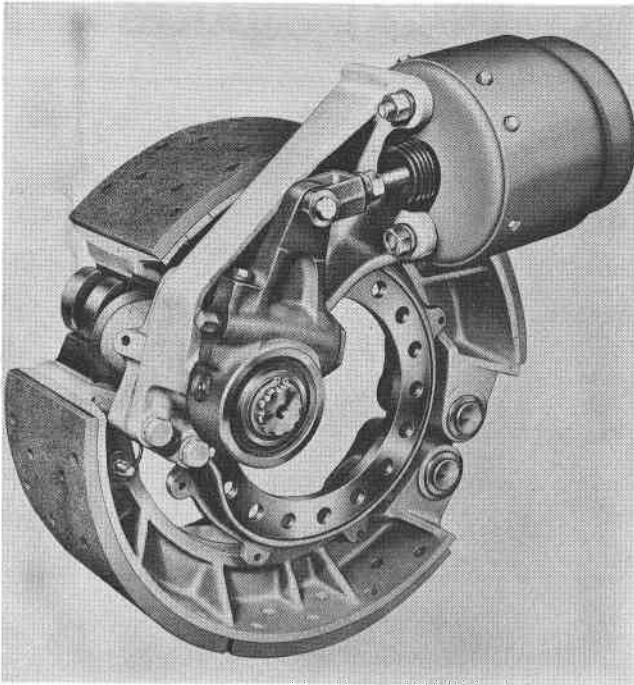

DISASSEMBLY

- A. Remove shoe return springs.
- B. Remove lock rings, retainers and felts from anchor pins.

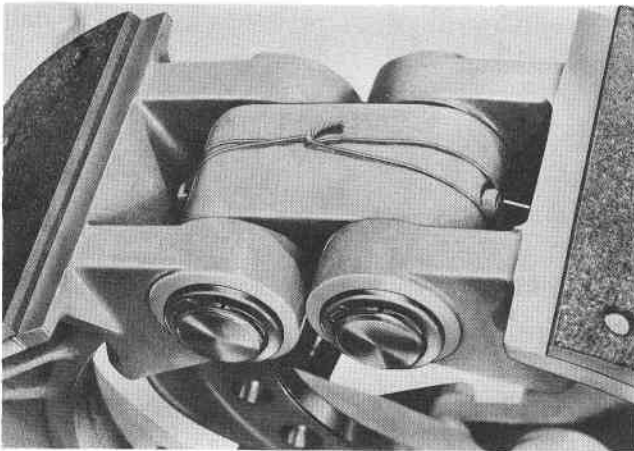

- C. Cut lock wire and remove anchor pin lock screws.
- D. Remove anchor pins and shoe assemblies.
- E. Remove air chamber mounting stud nuts and lock washers.
- F. Remove air chamber clevis pin cotter key, clevis pin and air chamber.
- G. Remove cam end lock ring and flat washer.
- H. Remove slack adjuster lever.
- I. Remove cam by tapping out from rear.

- J. Remove chamber bracket mounting cap screws and lock washers. Remove bracket.
- K. Remove needle bearings, only if replacement is to be made, by pressing out with a suitable sleeve.

ASSEMBLY

- A. Install new cage and needle bearing assemblies if replacement is necessary.
- B. Locate and secure with cap screw and lock washers the air chamber mounting bracket and tighten cap screws securely.
- C. Lubricate needle bearings with lubricant (specification of 0-615 or the equivalent).
- D. Install slack adjuster on cam so that shoes are in a fully released position and install cam washer and cam groove lock ring.
- E. Mount air chamber on bracket and secure with chamber mounting stud nuts and washers.
- F. Connect slack adjusting lever to air chamber pushrod clevis with clevis pin and cotter key.
- G. Install brake shoes with anchor pins and secure pins with felts, felt retainers and pin groove locking rings.
- H. Install anchor pin locking screws and lock wire.

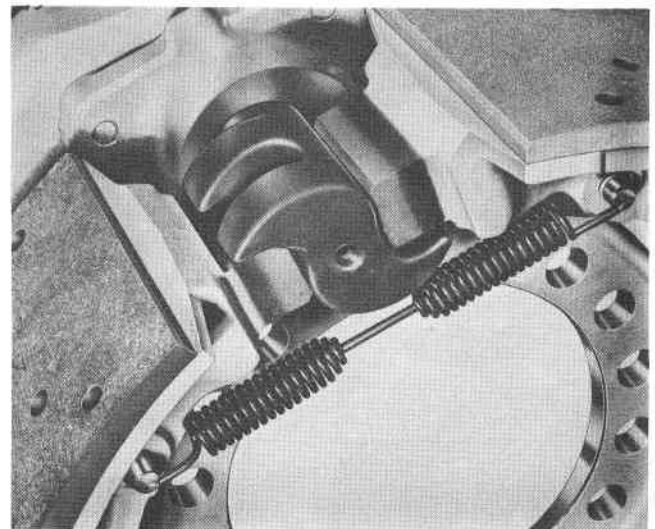

- I. Connect brake shoe return springs.

ADJUSTMENT

Follow adjustment procedure as outlined under "P" Brake section, located on bottom of page 14.

"DLM" DUPLEX LEVER MECHANICAL BRAKES

The "DLM" brake is a two shoe mechanical brake designed for use as either a control or parking brake.

Equal pressure is applied to both shoes through lever actuation in either forward or reverse rotation.

"DLM" brake shoes and springs are interchangeable. Brake is fully enclosed to exclude dirt or foreign matter.

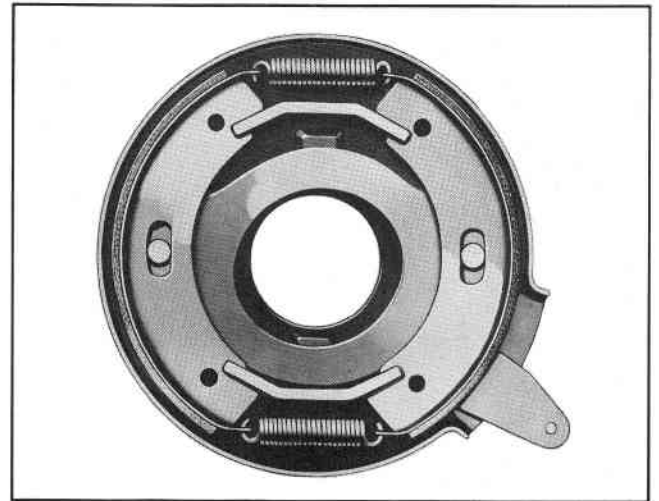

"DLM" BRAKE LAYOUT

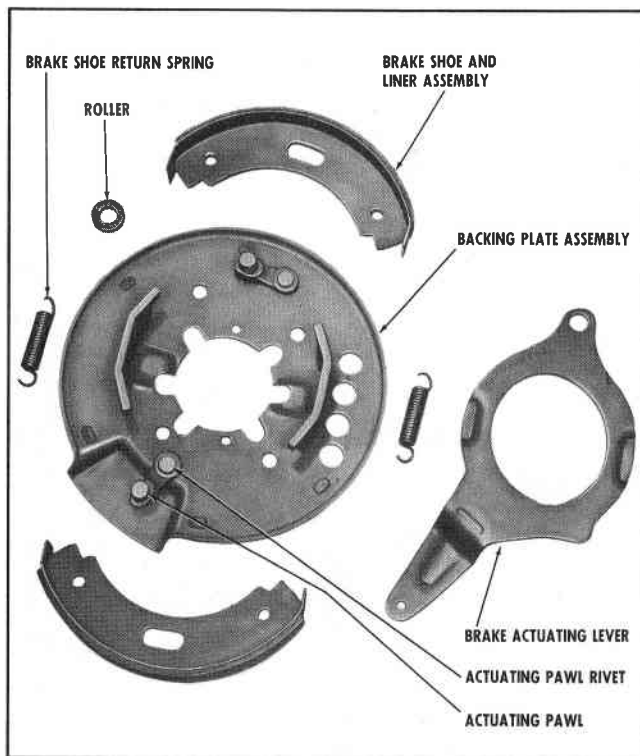

DISASSEMBLY

- A. Disconnect and remove brake shoe return springs.
- B. Remove brake shoes and liner assemblies.

- C. Lift out brake shoe lever.

ASSEMBLY

- A. Install brake lever over opposite pawl pin and position so that lever arm lies in backing plate depression.
- B. Install roller on remaining pawl.
- C. Install brake shoes.
- D. Connect brake shoe return springs in slots nearest backing plate.

Note: On smaller size "DLM" brakes two rollers are used, one on each pawl.

ADJUSTMENT

Equal alignment is completely controlled by the design of the actuating lever and the only adjustment necessary is through connecting linkage to lever arm.

"DM" DUPLEX MECHANICAL BRAKES

The "DM" brake is a two shoe mechanical brake designed for either service or parking use. The shoes are actuated by a lever and wedge and are self-aligning. The two shoes are interchangeable and do an equal amount of work in either forward or reverse direction.

The adjusting bolts in the abutment bracket provide a means for adjusting the brake shoe clearance with the drum.

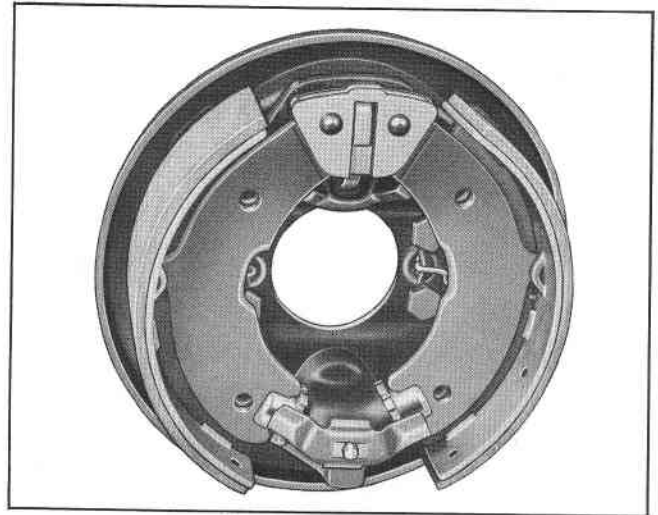

"DM" BRAKE LAYOUT

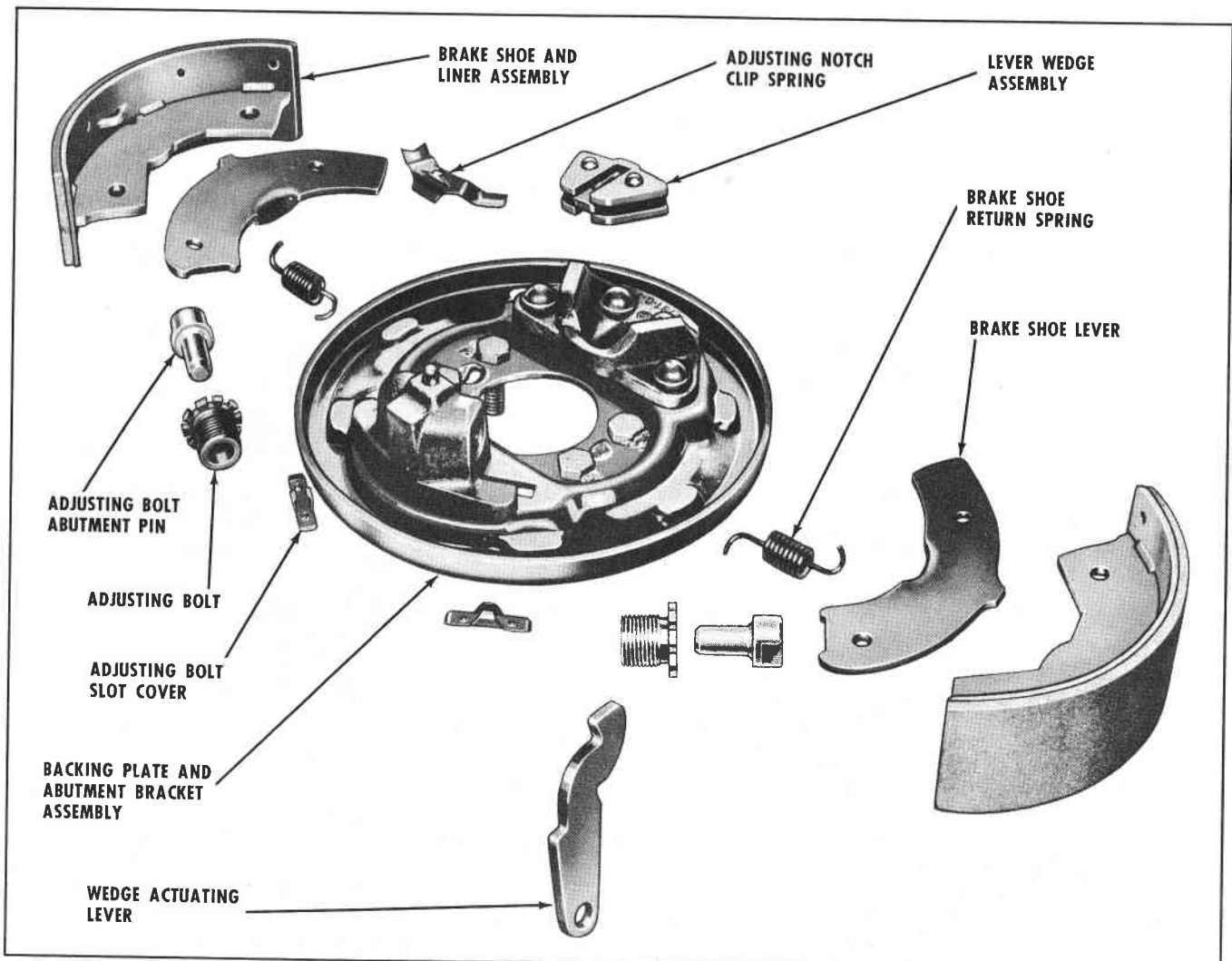

DISASSEMBLY

- A. Disconnect brake shoe return springs.

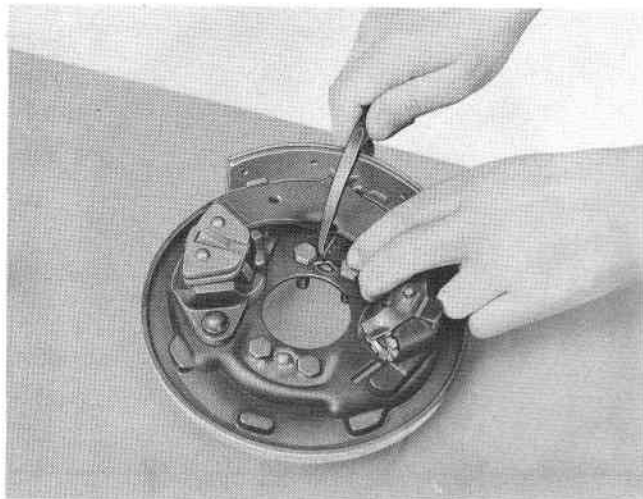

- B. Remove shoe and liner assemblies.
C. Remove levers and wedge assembly.
D. Remove abutment pins.
E. Screw out adjusting bolts.

- D. Insert straight end of return spring in shoe web and hook rounded end into backing plate catch.
E. Install brake shoe levers (formed pressure points contacting web pressure points).
F. Insert operating lever through top abutment slot.
G. Lubricate with specification 0-615 the wedge assembly side slots and install by spreading the shoe and lever assemblies.

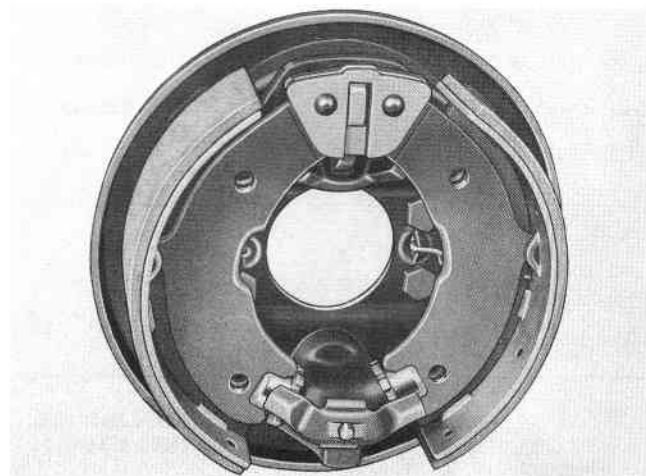

ASSEMBLY

- A. Lubricate and install adjusting bolts. Use specification 0-615.

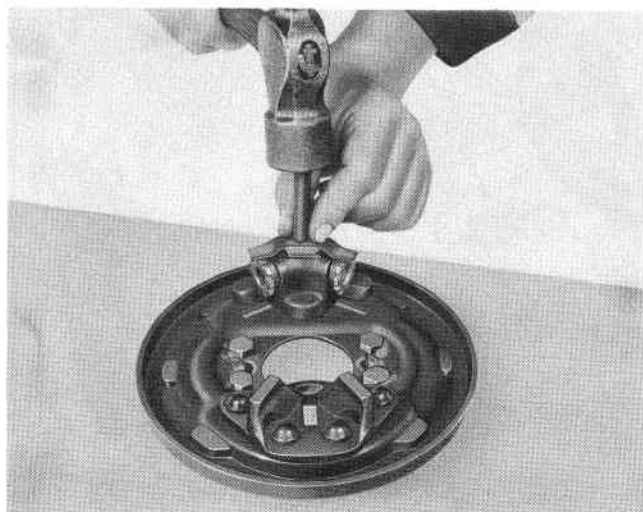

- B. Position abutment pins in adjusting bolts.
C. Install shoes on backing plate with web pressure points above center line.

- A. Insert adjusting spoon through slotted hole to engage lugs on adjusting bolt. Move handle up or down using slot end as a fulcrum. To expand shoes move tool handle down when in the L.H. slot and move tool handle up when in the R.H. slot.

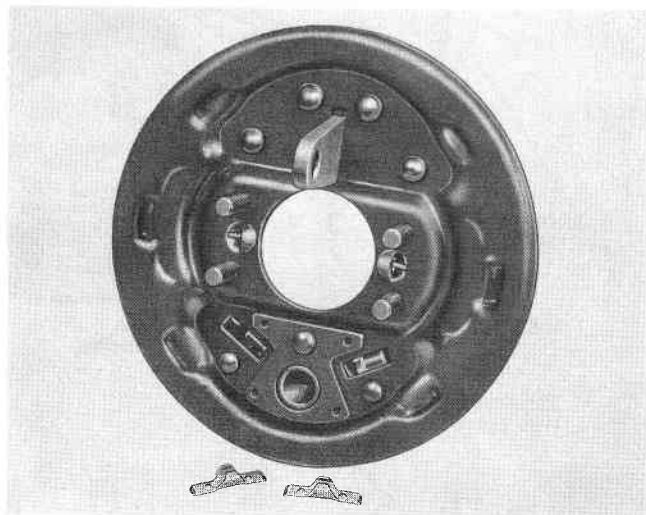

- B. Shoe liners should be brought out tight against the brake drum. Adjusting bolt should then be backed off until the drum can rotate freely. Brake shoes should be adjusted individually.
C. Replace adjusting slot cover.

NEW "VEE" BRAKES

The "VEE" brake is a mechanical wedge shoe type brake. The wedge shoe and liner assembly when actuated into the "V" of drum is equally effective in forward and reverse.

The drum mounts on the shaft to be controlled and pressure is applied through the lever. The "VEE" brake is used both as a service brake and a parking brake.

The "VEE" brake can be completely assembled before mounting into its enclosure.

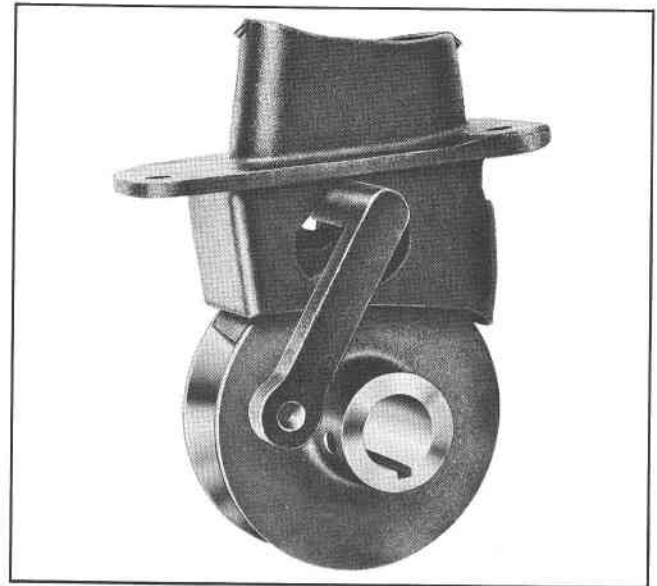

"VEE" BRAKE LAYOUT

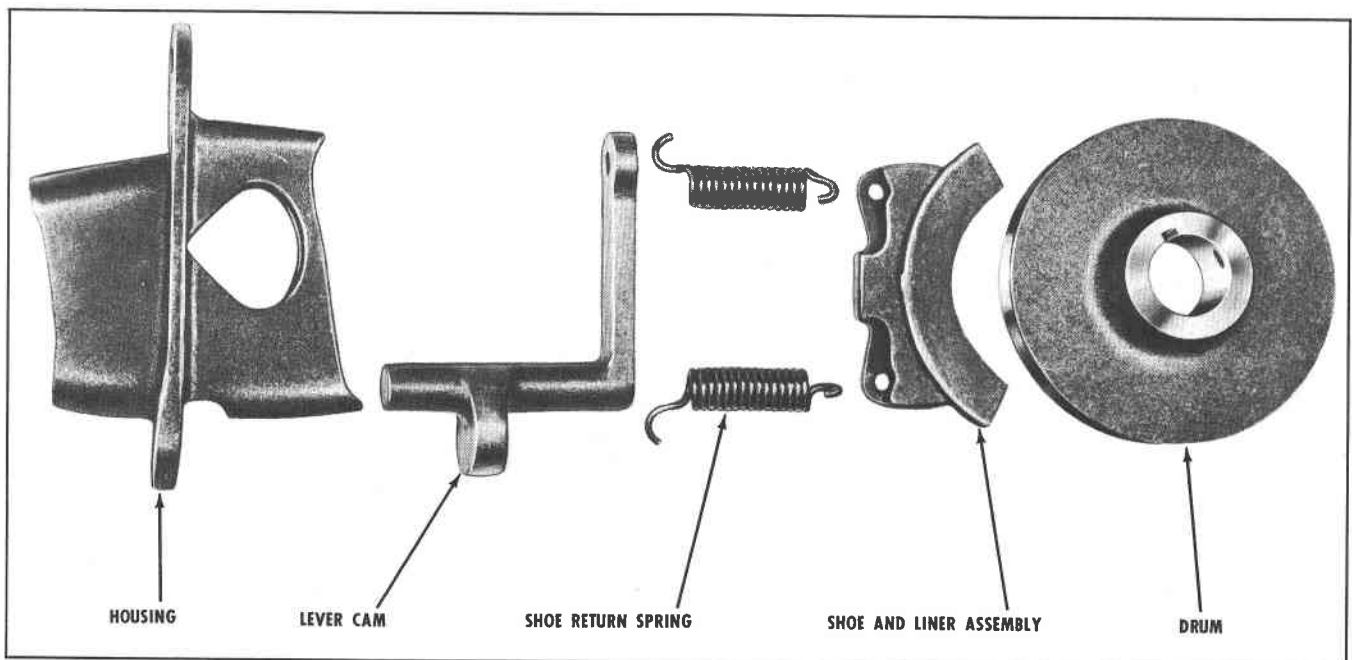

DISASSEMBLY

- A. Unhook return spring ends. (Use a buttonhook type of spring stretcher.)
- B. Remove lever by dropping shoe assembly and rotating lever cam to pass through opening.
- C. Remove shoe and spring assembly and unhook springs from shoe.

ASSEMBLY

- A. Lubricate housing abutment, shoe cam pad and lever cam bearing area.

- B. Insert small hook of springs into shoe with opposite hook ends out.
- C. Install lever and rotate cam so that shoe may be raised into actuating position.
- D. Hook spring end hooks into housing.

ADJUSTMENT

- A. Pull lever forward to maximum cam travel and back off $\frac{3}{8}$ ".
- B. Insert linkage connection pin.

Section IV

Axles

Rockwell Standard axles are used exclusively on Blue Bird chassis.

Illustrations, parts list, and field maintenance manuals are included to aid you in servicing, maintaining, and ordering replacement parts.

ALWAYS GIVE PART NUMBER OF EACH PART AND COMPLETE DESCRIPTION AND MANUFACTURER WHEN ORDERING PARTS.

FRONT AXLE WITH AIR BRAKES
FE-900-P-X-157

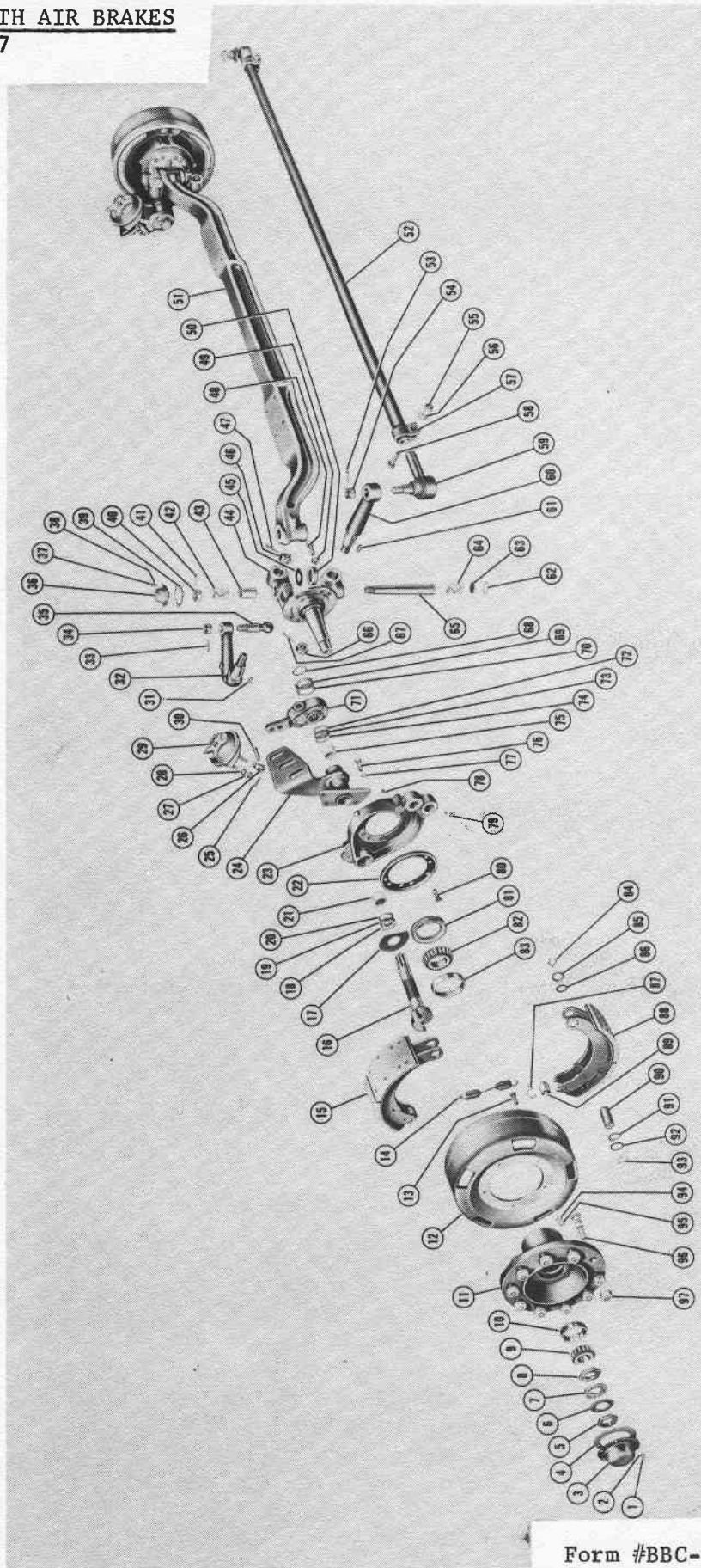

Form #BBC-65-IV-2
January 4, 1965

FRONT AXLE WITH AIR BRAKES
FE-900-P-X-157

KEY NO.	PART NUMBER	PART NAME	QTY.
1	S-255	Cap Screw	12
2	WA-15	Lock Washer	12
3	3262-A=53	Hub cap	2
4	2208-Y=363	Gasket	2
5	1227-B=106	Wheel bearing jam nut	2
6	1229-F=474	Bending Lock Washer	2
7	1229-G=475	Pierced Lock Washer	2
8	1227-U=541	Wheel Bearing Adjusting Nut (A-1227-L-194 opt.)	2
9	3782	Outer Wheel Bearing	2
10	3720	Outer Wheel Bearing Cup	2
11	A31-333-K-765	Wheel Hub and cup assembly	2
12	3219-E=2319	Brake Drum	2
13	S-1813=1	Hub to drum bolt	10
14	2258-Q-433	Brake Shoe Return Spring	2
15	A14-3722=D-82	Brake Shoe and Lining Assembly, upper	2
	A-3722=D-82	Brake Shoe Only	
16	2210-P=2434	RH Brake Camshaft	1
	2210-Q=2435	LH Brake Camshaft	1
17	1229-E=837	Camshaft Washer	2
18	1205-W-205	Felt Seal Retainer	2
19	5X-191	Brake Spider Felt Seal	2
20	1229-J=868	Washer	2
21	1225-N=378	Brake Spider Bushing	2
22	3286-Z=156	Wheel Bearing Oil Slinger	2
23	A=3711-Z=104	RH Brake Spider	1
	A-3711-Y=103	LH Brake Spider	1
24	A1-3799=R=564	RH Camshaft and Chamber Bracket	1
	A1-3799-S=565	LH Camshaft and Chamber Bracket	1
25	K-248	Cotter Pin	2
26	1245-J-192	Brake Chamber Yoke	2
27		Brake chamber stud nut	
28	WA-17	Brake chamber stud nut lockwasher	4
29	G5-3276-P-16	Brake Chamber	2
30	19-X=45	Yoke Pin	2
31	16-X=204	Steering Arm Key	1
32	3133-H-1698	Steering Arm	1
33	K-2616	Cotter Pin	1
34	N-214	Steering Arm Ball Nut	1
35	2110-V-100	Steering Arm Ball	1
36	*1199-J-1258	Steering Knuckle Pin Cap	2
37	*A-10X-468	Cap Screw	6
38		Lock Washer	
39	*2208-M-377	Gasket	2
40	*1227-R-434	Knuckle Pin Nut	2
41	*K-2412	Cotter Pin	2
42	*1225-Z-338	Upper Knuckle Pin Bushing	2
43	*1244-S-747	Knuckle Pin Metal Sleeve	2
44	A-3111-P-718-RH	Steering Knuckle	1
	A-3111-Q-719-LH	Steering Knuckle	1
45	*2203-V-2856 (.010)	Steering Knuckle Spacing Shim	2AR
46	14-X-27	Steering Arm Nut	1
47	K-2616	Cotter Pin	1

FRONT AXLE WITH AIR BRAKES
FE-900-P-X-157 (Continued)

KEY NO.	PART NUMBER	PART NAME	QTY.
48	S-9816	Steering Knuckle Stop Screw	2
49	13-X-161	Stop Screw Lock Nut	2
50	*T-163	Steering Knuckle Thrust Bearing	2
51	3100-M-3055	Axle Center	1
52	A-3102-V-2128	Steering Cross Tube Assembly	1
53	K-2412	Cotter Pin	2
54	N-514	Cross tube end ball nut	2
55	N-110	Cross Tube Clamp Ball Nut	2
56	WA-110	Lock Washer	2
57	2257-Q-17	Cross Tube Clamp	2
58	S-11022	Cross Tube Clamp Bolt	2
59	A-3144-R-226	RH Cross Tube End Assembly	1
	A-3144-S-227	LH Cross Tube End Assembly	1
60	3133-J-998	RH Cross Tube Arm	1
	3133-K-999	LH Cross Tube Arm	1
61	16-X-204	Square Key	2
62	*1229-W-1141	Expansion Plug Lock Ring	2
63	*1250-Q-173	Expansion Plug	2
64	*1225-W-517	Lower Knuckle Pin Bushing	2
65	*3101-B-80	Knuckle Pin	2
66	14-X-27	Cross Tube Arm Nut	2
67	K-2616	Cotter Nut	2
68	1229-B-1302	Snap Ring	2
69		Spacer	
70	1229-R-122	Spacer	
71	A3-3275-G-501	Slack Adjuster	2
72	1205-W-205	Felt Seal Retainer	2
73	5X-191	Camshaft & Chamber Bracket Felt Seal	2
74	1229-J-868	Washer	2
75	1225-N-378	Camshaft and Chamber Bracket Bushing	2
76	S-2812	Bracket to Spider Cap Screw	8
77	WA-18	Lock Washer	8
78	S-864	Brake Anchor Pin- Upper Set Screw	2
79	S-864	Brake Anchor Pin- Lower Set Screw	2
80	RV-5812	Brake Spider to Steering Knuckle Rivet	16
81	A-1205-G-631	Wheel Bearing Oil Seal	2
82	HM-212044	Inner Wheel Bearing	2
83	HM-212011	Inner Wheel Bearing Cup	2
84	1218-L-90	Brake Anchor Pin Retainer Spring	8
85	1205-K-193	Brake Anchor Pin Retainer	8
86	5-X-640	Brake Anchor Pin Felt	8
87	1718-Y-103	Brake Shoe Roller Retainer spring	4
88	A15-3722-D-82	Brake Shoe & Lining Assembly - Lower	2
89	1779-R-18	Brake Shoe Roller	4
90	1759-M-13	Brake Anchor Pin	4
91	5-X-640	Brake Anchor Pin Felt	8
92	1205-K-193	Brake Anchor Pin Retainer	8
93	1218-L-90	Brake Anchor Pin Retainer Spring	8
94	WA-18	Lock Washer	10
95	N-18	Hub to Drum Bolt Nut	10
96	20X-370	RH Wheel Stud	10
	20X-369	LH Wheel Stud	10
97	1199-N-118	RH Wheel Stud Nut	10
	1199-M-117	LH Wheel Stud Nut	10

FRONT AXLE WITH AIR BRAKES
FE-900-P-X-157 (Continued)

<u>KEY NO.</u>	<u>PART NO.</u>	<u>PART NAME</u>	<u>QTY.</u>
*NI	2203-A-807	Steering Knuckle Spacing Shim	2
*NI	1229-U-1087	Steering Knuckle Spacing Washer	1
*NI	1229-V-1088	Steering Knuckle Spacing Washer	1
NI	KIT-123	Steering Knuckle Pin Repair Kit	1
NI	2000-E-135	Brake Shoe Lining Kit with Rivets	1

*Parts contained in Repair Kit #KIT-123

FRONT AXLE FOR HYDRAULIC BRAKES
FE-900-H-X-73

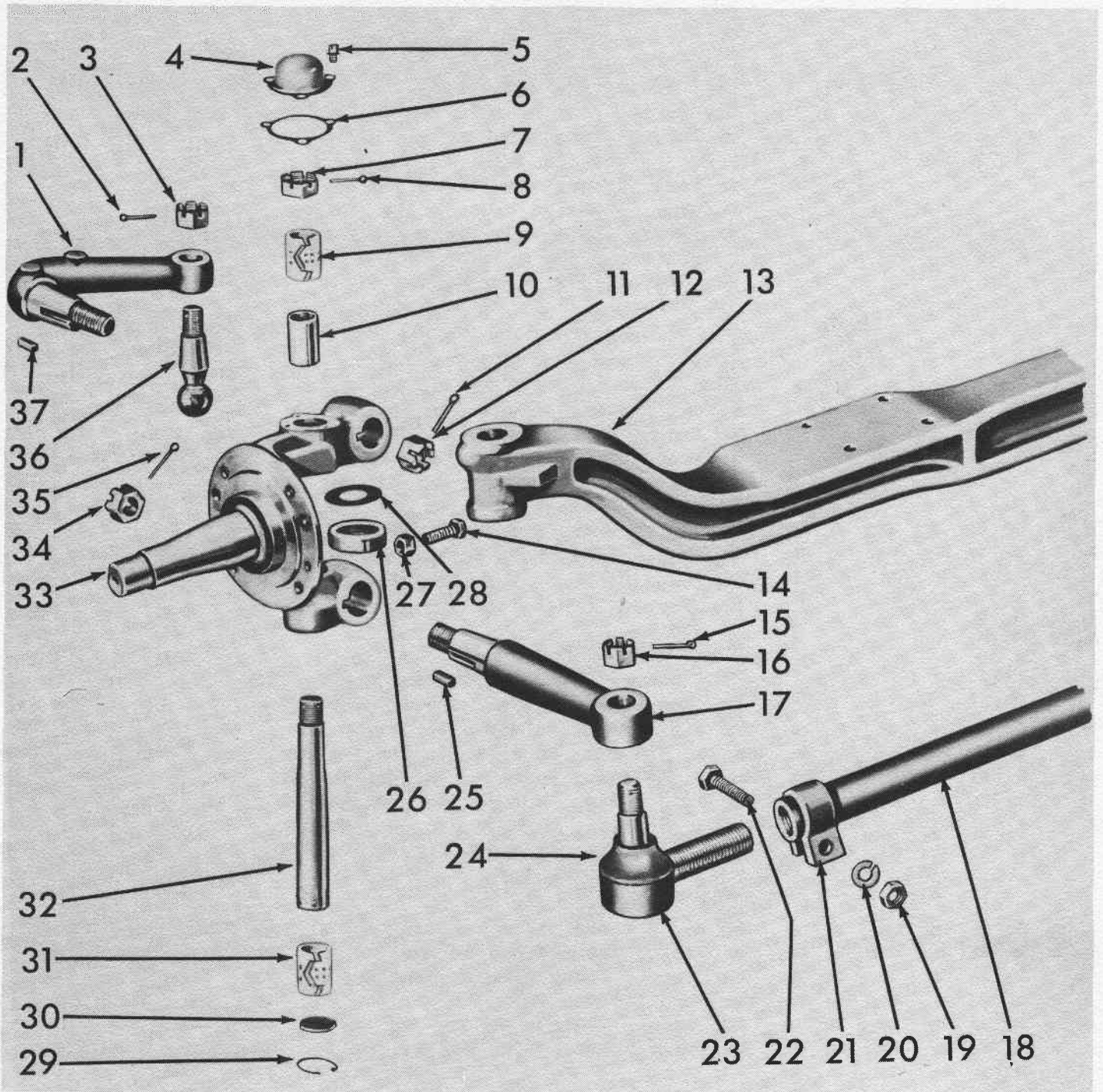

FRONT AXLE FOR HYDRAULIC BRAKES
FE-900-H-X-73

KEY NO.	PART NO.	PART NAME	QTY.
1	3i33-H-1698	Arm, steering	1
2	K-2412	Cotter, Steering Arm Ball & Nut	1
3	N-214 -	Nut, Steering Arm Ball	1
4	*1i99-f-1258	Cap, Steering Knuckle Pin	2
5	*A-10x-468	Screw, Steering Knuckle Pin Cap	6
6	*2208-M-377	Gasket, Steering Knuckle Pin Cap	2
7	*1227-R-434	Nut, Steering Knuckle Pin	2
8	*K-24i2-	Cotter, Steering Knuckle Pin Nut	2
9	*1225-W-517	Bushing, Steering Knuckle Pin	2
10	*1244-S-747	Spacer, Steering Knuckle Upper Bushing Cap	2
11	K-2616	Cotter, Steering Cross Tube Arm Nut	1
12	14X-27-	Nut, Steering Cross Tube Arm	1
13	3i00-M-3055	Axle Center	1
14	S-9816	Screw, Steering Knuckle Stop	2
15	K-2412	Cotter Cross Tube End Nut	2
16	N-214 -	Nut, Cross tube end	2
17	3133-J-998	RH Arm steering cross Tube	1
	3i33-K-999	LH Arm Steering Cross Tube	1
18	A=3102-V-2128	Tube and Clamp Assy., Steering & Cross	1
19	N-i10	Nut, Steering Cross Tube End Clamp	2
20	WA-1i0-	Lock washer Steering Cross Tube End Clamp	2
21	2257-Q-17	Clamp, steering Cross Tube End	2
22	S=11022 -	Bolt, Steering Cross Tube End Clamp	2
23	A=3144-R=226	RH Steering Cross Tube End assembly	1
24	A=3144-S=227	LH Steering Cross Tube End assembly	1
25	16X-204	Key, Steering Cross Tube Arm	2
26	*T-i63	Bearing, Steering Knuckle Pin Thrust	2
27	13-X-161	Nut, Steering Knuckle Stop Screw	2
28	*2203-A-807	Shim, steering knuckle pin spacing	2AR
	*2203-V-2856	Shim, Steering knuckle pin spacing	2AR
29	*1229-W=1141	Lock, Steering Knuckle Pin Expansion Plug Retainer	2
30	*1250-Q=173	Plug, steering knuckle pin expansion	2
31	*1225-W-517	Bushing, Steering Knuckle Pin	2
32	*3i01-B-80	Pin, Steering Knuckle	2
33	A-3111-P=718	RH Knuckle Steering	1
	A-3i11-Q-719	LH Knuckle Steering	1
34	14X-27	Nut, Steering Cross Tube Arm	2
35	K-26i6-	Cotter, Steering Cross Tube Arm Nut	2
36	2110-V-100	Ball, Steering Arm	1
37	16X-204	Key, Steering Arm Nut	1
NI	KIT-123	Steering knuckle pin repair kit	1

*Parts contained in Repair Kit #KIT-123.

FRONT AXLE HUBS AND DRUMS FOR HYDRAULIC BRAKES
FE-900-H-X-73

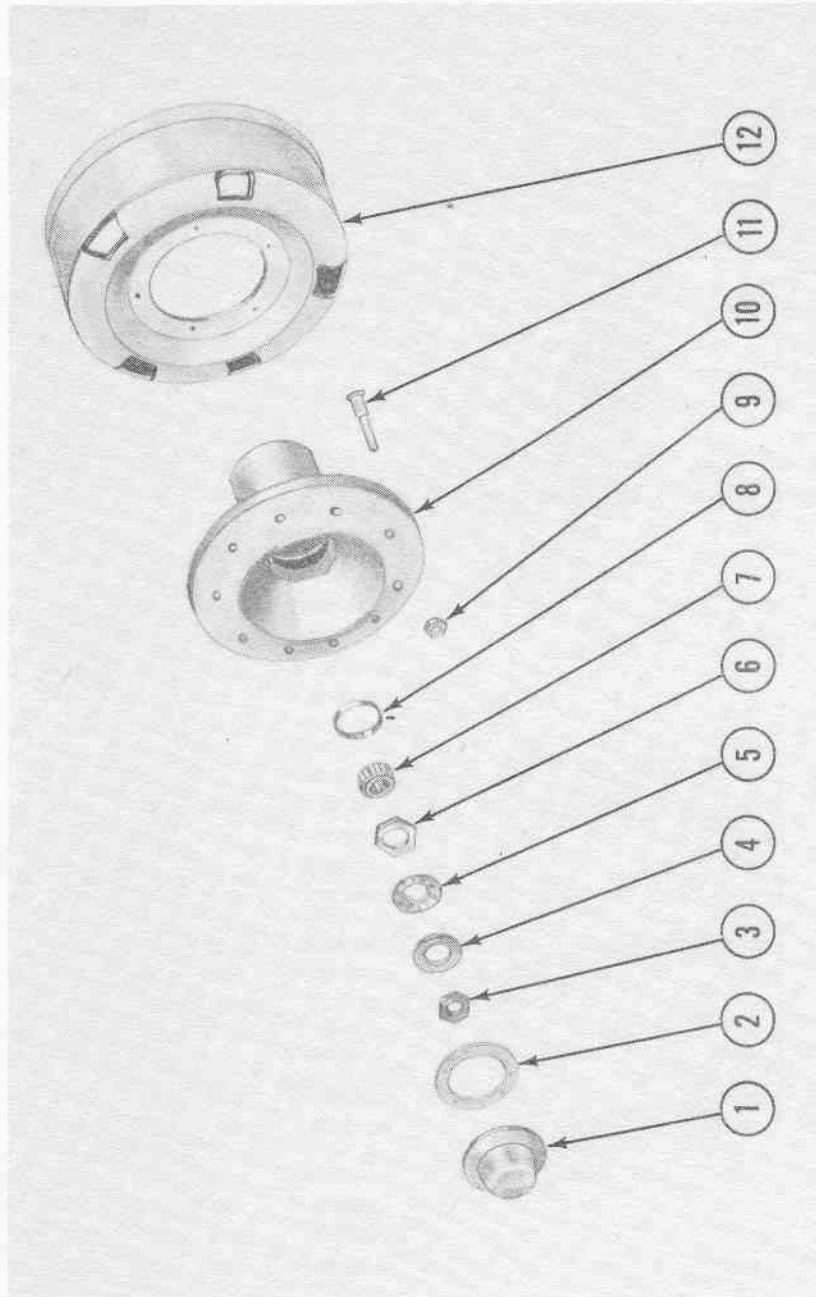

FRONT AXLE HUBS AND DRUMS FOR HYDRAULIC BRAKES
FE-900-H-X-73

<u>KEY NO.</u>	<u>PART NO.</u>	<u>PART NAME</u>	<u>QTY.</u>
1	3262-A-53	Hub cap	2
2	2208-Y-363	Gasket, hub cap	2
3	1227-B-106	Nut, wheel bearing adjusting nut jam	2
4	1229-F-474	Lock, wheel bearing adjusting nut jam nut	2
5	1229-G-475	Lock ring, wheel bearing adjusting nut	2
6	1227-U-541	Nut, wheel bearing adjusting	2
7	3782	Cone, wheel bearing, outer	2
8	3720	Cup, wheel bearing, outer	2
9	1199-N-118	Hub and wheel stud cap nut - RH	10
	1199-N-117	Hub and wheel stud cap nut - LH	10
10	A31-333-K-765	Hub and cup assembly	2
11	20X-370	Hub and wheel stud - RH	10
	20X-369	Hub and wheel stud - LH	10
12	3219-M-1963	Drum, brake	2
NI	HM-212011	Cup, wheel bearing, inner	2
NI	HM-212044	Cone, wheel bearing, inner	2
NI	A-1205-G-631	Oil seal, wheel bearing	2

FRONT AXLE HYDRAULIC BRAKES
FE-900-H-X-73

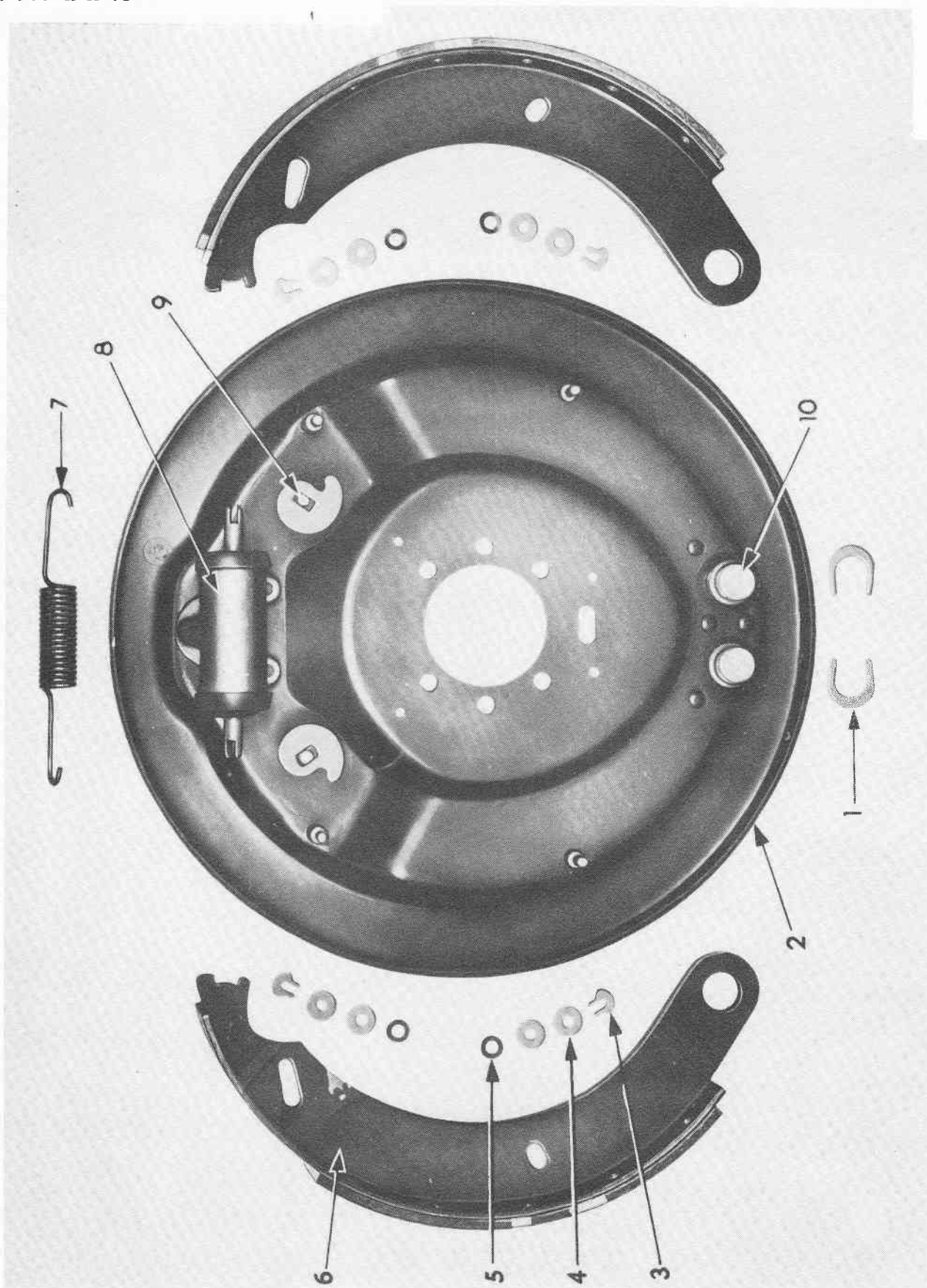

FRONT AXLE-HYDRAULIC BRAKES

FE-900-H-X-73

<u>KEY NO.</u>	<u>PART NO.</u>	<u>PART NAME</u>	<u>QTY.</u>
1	1229-M-221	Anchor Pin "C" Washer	4
2	A-3236-A-885	Backing Plate Assembly	2
3	1829-L-194	Guide Pin Lock	8
4	1229-N-222	Guide Pin Washer	8
5	1829-P-198	Guide Pin Spring Washer	8
6		Brake Shoe and Lining Assembly	
	A-15-3722-R-174	Forward	2
	A-16-3722-R-174	Reverse	2
	A-3722-R-174	Shoe Only	
7	2858-B-28	Brake Shoe Return Spring	2
8	A11-3261-P-16	Wheel Cylinder Assembly	2
9	A-2847-G-137	Brake Shoe Eccentric Adjuster	4
10	1759-Y-25	Adjustable Brake Shoe Anchor Pin	4
NI	S-267	Wheel Cylinder Capscrew	2
NI	WA-16	Wheel Cylinder Capscrew Lockwasher	2
NI	1745-A-1	Wheel Cylinder Push Rod	2

REAR AXLE WITH SINGLE SPEED CARRIER
L-148-P-X-1

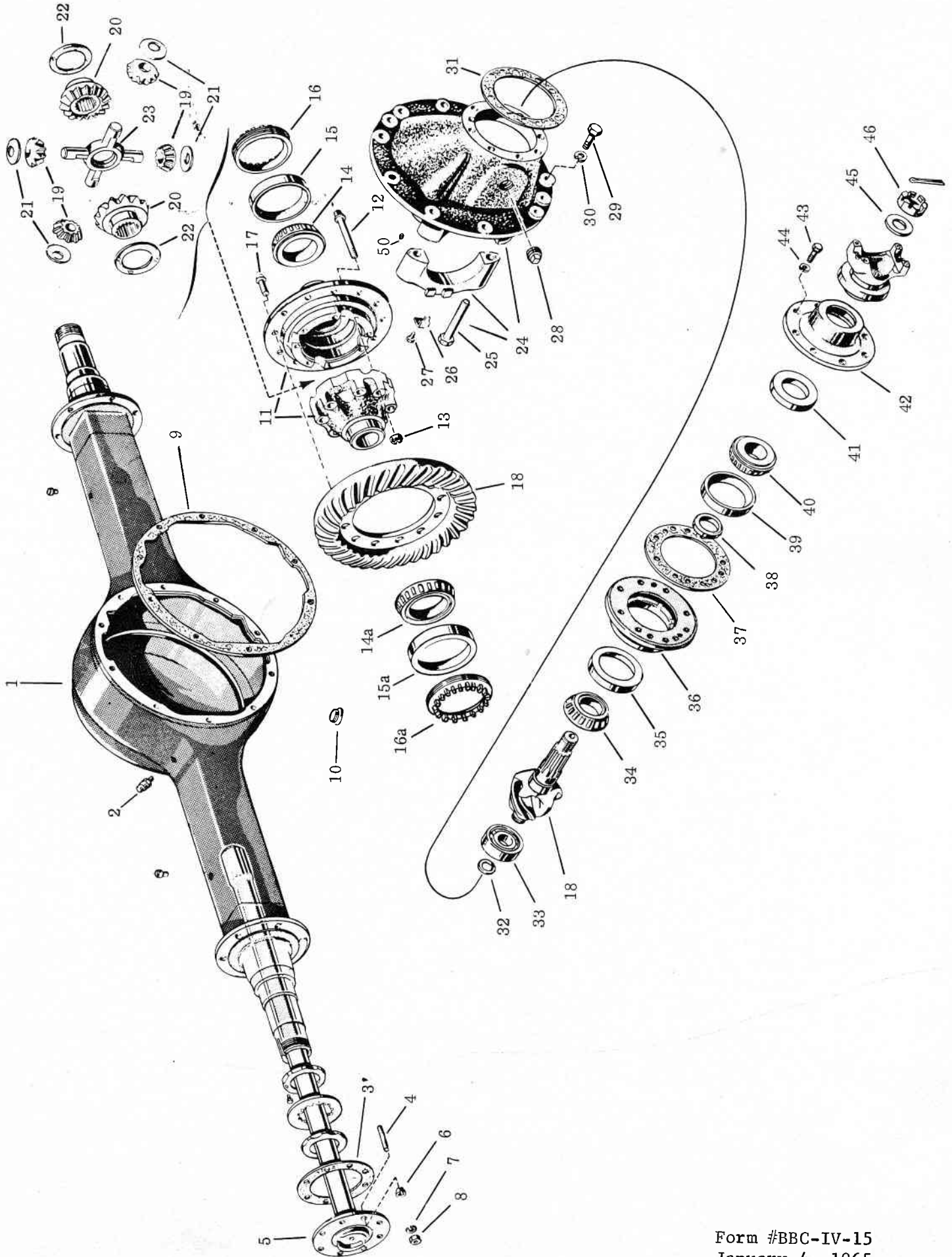

REAR AXLE WITH SINGLE SPEED CARRIER

L-148-P-X-1

KEY NO. PART NO.

KEY NO.	PART NO.		
1	A4-3201-U-1581	Hsg. Ay. Axle (Dodge)	1
	A6-3201-U-1581	Hsg. Ay. Axle (Reo)	
	A7-3201-U-1581	Hsg. Ay. Axle (White)	
2	A-1199-P-1394	Breather, Axle Hsg.	1
3	2208-F-422	Gasket, Axle Flange	4
4	4-X-759	Stud, Axle Shaft	24
5	3202-G-2971	Axle Shaft	2
6	1246-Z-234	Dowel, Axle Shaft Stud	24
7	1229-U-515	Lockwasher, Axle Shaft Stud Nut	24
8	N-17	Nut, Axle Shaft Stud	24
9	2208-B-444	Gasket, Carr. to Axle Hsg.	1
10	P-212	Plug, Axle Hsg. Drain	1
11	A-3235-R-616	Case, Diff. Spider	1
		Case, Diff. Spider	
12	15X-924 (Short)	Bolt, Diff. Case	8
	15X-925 (Long)	Bolt, Diff. Case	4
13	N-28	Nut, Diff. Case Bolt	12
14	42688	Cone, Brg. Diff. Case - LH	1
14a	34301	Cone, Brg. Diff. Case - RH	1
15	42620	Cup, Brg. Diff. Case - LH	1
15a	34500	Cup, Brg. Diff. Case - RH	1
16	2814-W-75	Adj. Diff. Brg. - LH	1
16a	2814-W-75	Adj. Diff. Brg. - RH	1
17	RV-71013	Rivet, Dr. Gr. to Diff. Case 9/16", Cpt..w/bolt	12
	Gear and Pinion Set		
18	A35776 5=2/7-1	(Gr. 35776 Pn. 35603)	
	A35778 5=5/6-1	(Gr. 35778 Pn. 35709)	
	A35732 6-1/6-1	(Gr. 35732 Pn. 35649)	
	A35774 6-5/6-1	(Gr. 35774 Pn. 35647)	
	A35772 7-1/5-1	(Gr. 35772 Pn. 35601)	
19	2233-Y-103	Gr. Diff. Pinion	4
20	2234-F-266	Gr., Axle Side	2
21	1229-R-1032	Washer, Spider Pn. Gr.	4
22	1229-T-1034	Washer, Axle Side Gr.	2
23	3278-H-86	Spider, Diff.	1
24	A2-3200-T-540	Carrier W/Caps	1
25	10-X-544	Bolt, Diff. Brg. Cap	4
26	1820-T-46	Lock, Diff. Brg. Adj.	2
27	3-X-159	Screw, Diff. Brg. Adj. Lock	4
28	P-112	Plug, Diff. Case Oil Level	1
29	4-X-1050	Stud, Carr. to Axle Hsg. Long	4
	4-X-1083	Stud, Carr. to Axle Hsg. Short	10
30	N-18	Nut	14
31	2208-B-418	Gasket, Pn. Brg. Cage to Carr.	1
32	1229-V-334	Ring, Pn. Rear Brg. Lock	1
33	1228-Z-52	Brg. Pn. Rear	1
34	55200C	Cone, Pn. Brg. - Inner	1
35	55437	Cup, Pn. Brg. - Inner	1
36	T358	Cage, Pn. Brg.	1

REAR AXLE WITH SINGLE SPEED CARRIER

H-140-DH-X-58

H-140-P-X-51

KEY NO.	PART NO.	PART NAME	QTY.
	(continued)		
	2203-T-1060	.224	
	2203-U-1061	.230	
	2203-V-1062	.236	
	2203-W-1063	.242	
	2203-X-1064	.248	
	2203-Y-1065	.254	
39	55443	Cup, Pn. Brg. Forward	1
40	55176 --	Cone, Pn. Brg. Forward	1
41	A-1205=U-515	Seal, Pn. Oil	1
42	3266=5-83	Cover, Pn. Brg. Cage	1
43	2714-1	Screw, Pn. Brg. Cage to Carr.	8
44	WA17--	Lockwasher, Pn. Brg. Cage Screw	8
45	1229-E-1331	Washer, Pn. Flange Nut	1
46	13399 --	Nut, Pn. Flange	1
47	2297=Q-563	Block, Drive Gear Thrust	1
48	10=X-383	Screw, Dr. Gr. Thrust block adj.	1
49	13-X-13	Nut, Dr. Gr. Thrust Block Screw Lock	1
50	1246-D-342	Dowel, Diff. Brg. Cap	2
51	P212	Plug, Oil Filler	1

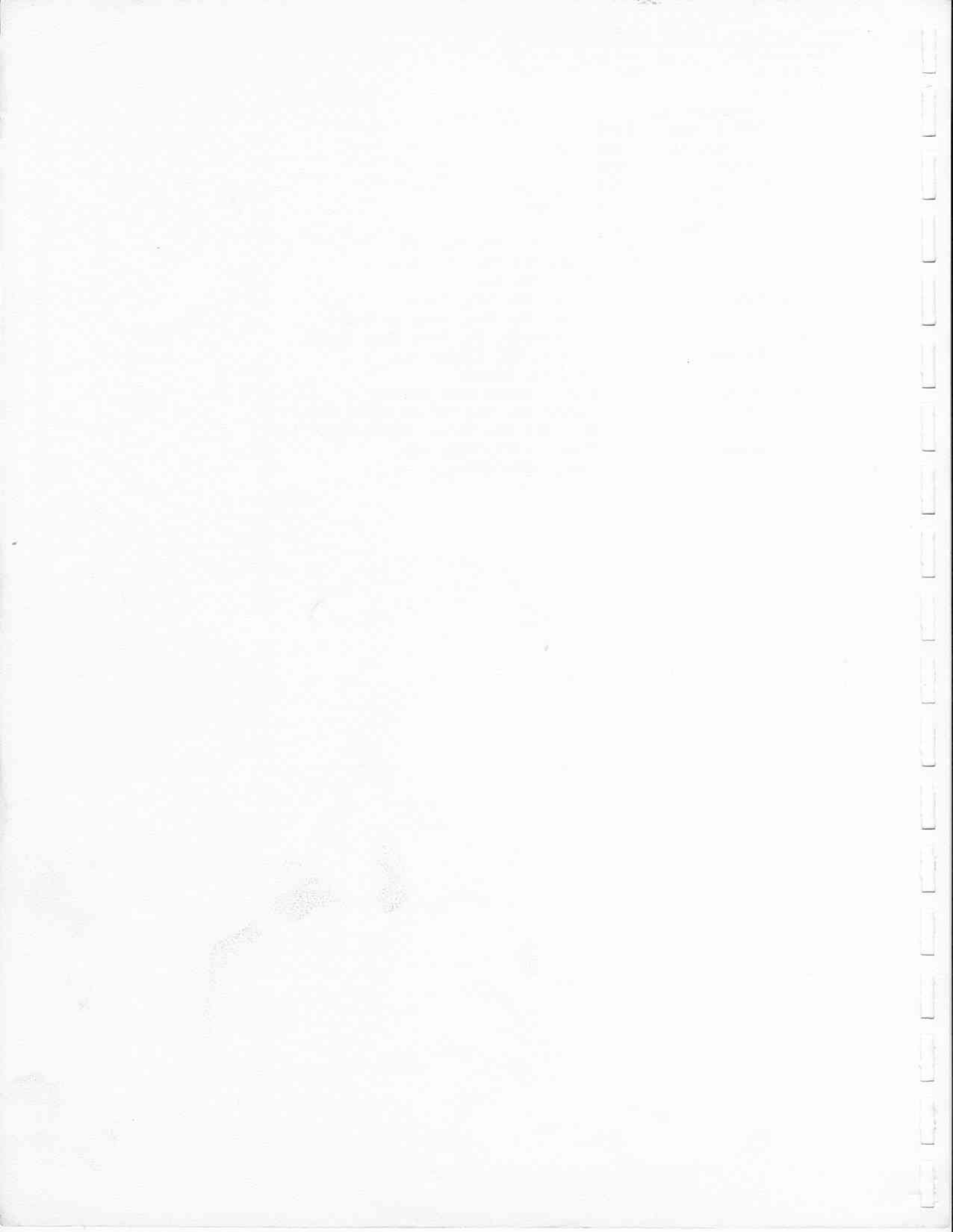

REAR AXLE WITH SINGLE SPEED CARRIER
 L-148-P-X-1 (Continued)

KEY NO.	PART NO.	PART NAME	QTY.
37		Shim, Pinion Bearing Cage	AR
	2203-H-450	Thin - .005	
	2203-J-452	Med. - .010	
	2203-K-453	Thick - .030	
38		Spacer, Pinion Bearing	AR
	2203-M-2509	.187	
	2203-N-2510	.188	
	2203-P-2512	.189	
	2203-Q-2513	.190	
	2203-R-2514	.191	
	2203-S-2515	.192	
	2203-T-2516	.198	
	2203-U-2517	.204	
	2203-V-2518	.210	
	2203-W-2519	.216	
	2203-X-2520	.222	
	2203-V-4104		
39	55437	Cup, Pn. Brg. Forward	1
40	55187	Cone, Pn. Brg. Forward	1
41	A-1805-B-80	Seal, Pn. Oil	1
42	A-3266-L-142	Cover, Pn. Brg. Cage	1
43	S-2714-1	Screw, Pn. Brg. Cage to Carr.	8
44	WA-17	Lockwasher, Pn. Brg. Cage Screw	8
45	1229-P-1030	Washer, Pn. Flange Nut	1
46	14X-57	Nut, Pn. Flange	1
NI	P-112	Plug, Carrier Filler	1

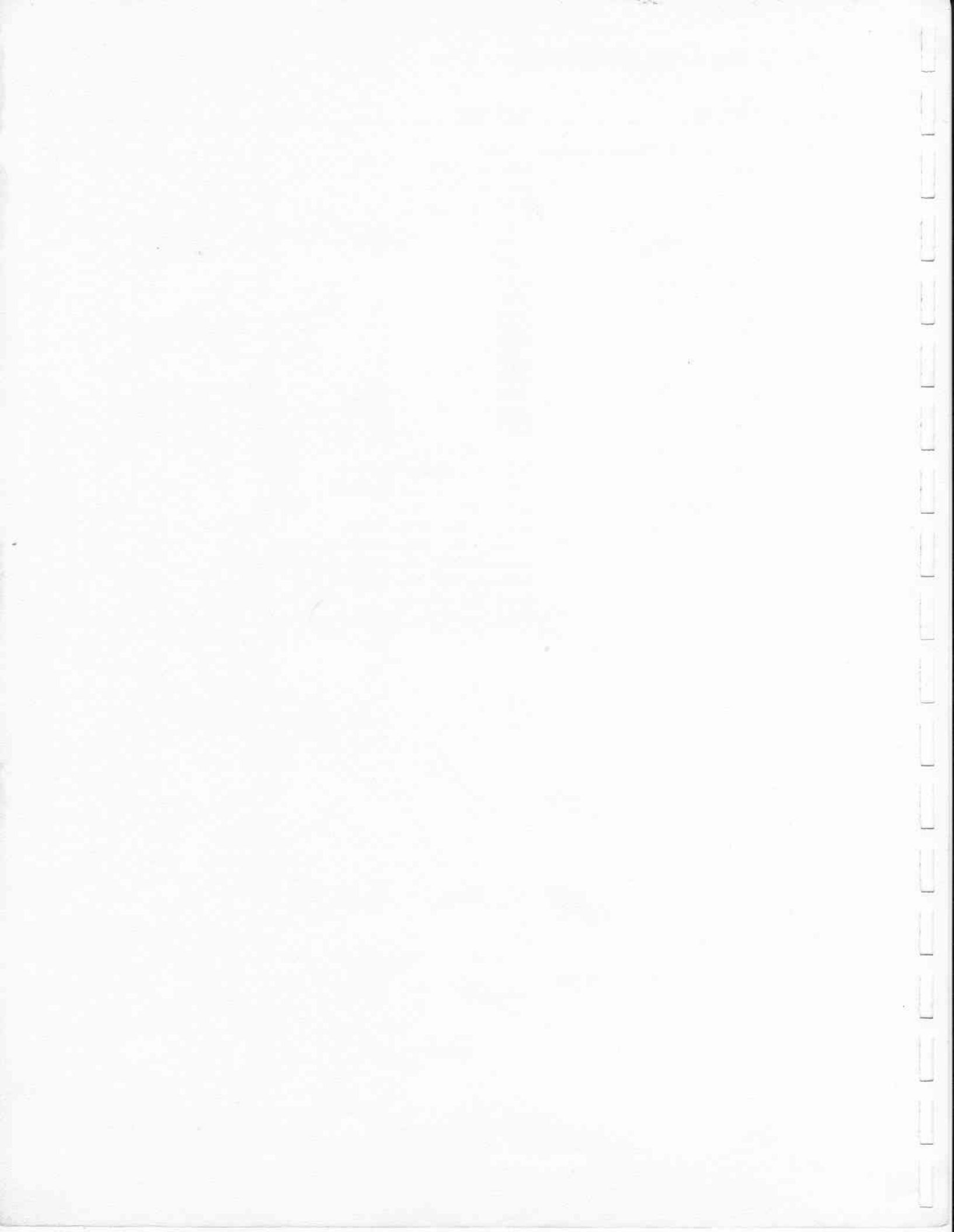

REAR AXLE WITH TWO-SPEED CARRIER

H-340

L-345

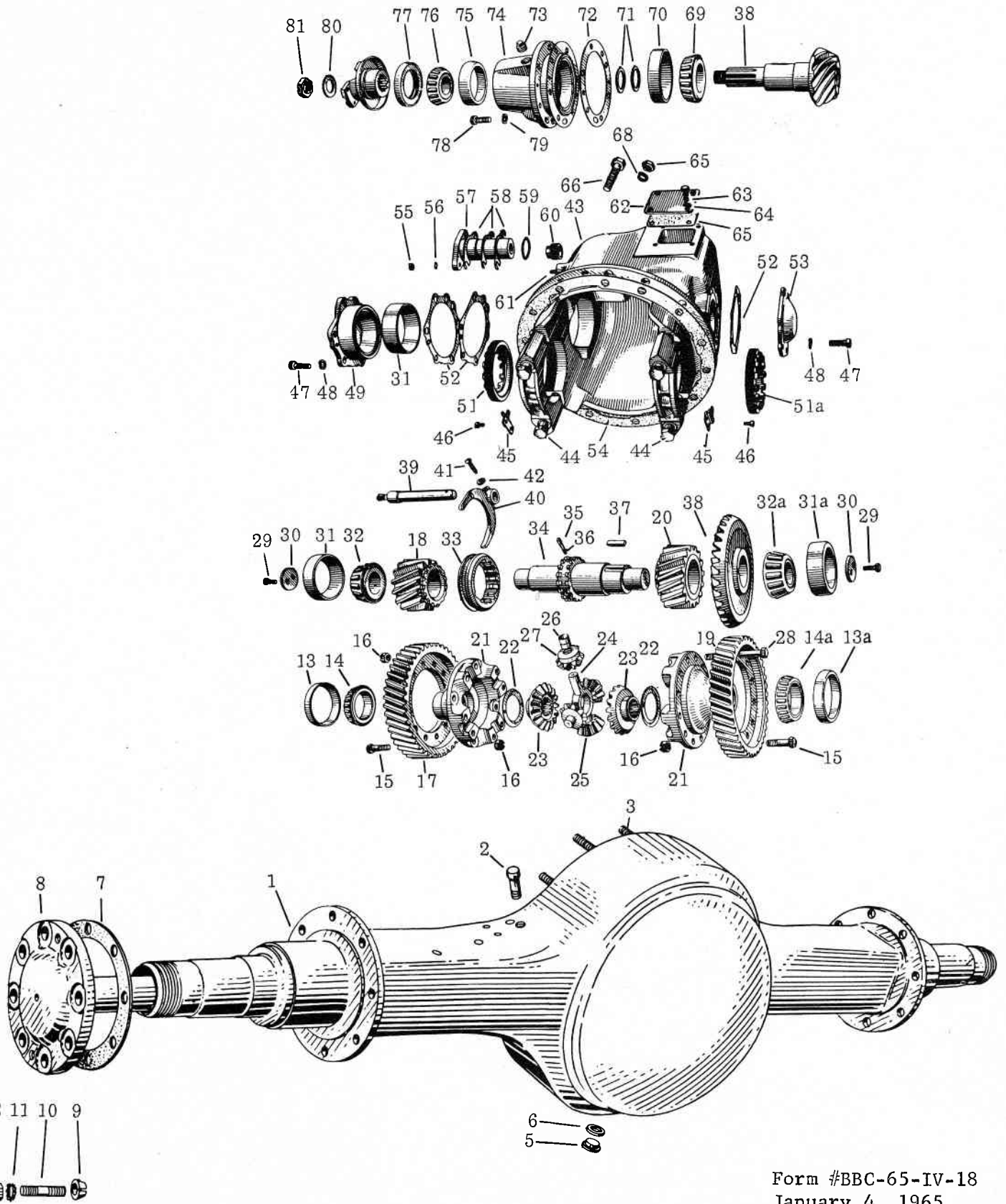

REAR AXLE WITH TWO-SPEED CARRIER
H-340

KEY NO.	PART NO.	PART NAME	QTY.
1	A22-3201-A-1587	Axle Housing assembly	1
2	A-1199-P-1394	Axle Housing Breather	1
3	4X-1050	Stud, Diff. Carrier & Housing (Long)	4
4	4X-1083	Stud, Diff. carrier & Housing (Short)	10
5	P-212	Plug, Housing drain hole	1
6	2208-4-441	Gasket, housing drain hole plug	3
7	2208-J-426	Gasket, axle shaft	4
8	3202-L-3002	Shaft, axle	2
9	1246-T-306	Dowel, axle shaft	16
10	4X-356	Stud, axle shaft	16
11	1229-V-516	Washer, axle shaft stud nut	16
12	N-18	Nut, axle shaft stud	16
13	33462	Cup, differential bearing - LH	1
13a	33462	Cup, differential bearing - RH	1
14	33281	Cone, differential bearing-LH	1
14a	33281	Cone, differential bearing-RH	1
15	15X-746	Bolt, differential case - long	8
16	N-210-1	Nut, differential case bolt	16
NI	1229-U-1503	Washer, differential case bolt	8
17	3892-U-1529	Gear, differential helical driven (fast) 6.16	1
18	3891-D-940	Gear, drive pinion (fast) 6.16	1
19	3892-S-1527	Gear, differential helical driven (slow) 8.48	1
20	3891-B-938	Gear, drive pinion (slow) 8.48	1
21	A-3835-G-345	Case assembly, differential	1
22	1229-M-1027	Washer, differential side gear thrust	2
23	2234-G-267	Gear, differential side	2
24	3278-M-143	Spider, differential	1
25	2233-M-117	Pinion, differential	4
27	1229-L-1026	Washer, differential pinion thrust	4
28	RV-7812	Rivet, differential & drive gear	12
31	59412	Cup, gear shaft bearing, LH	1
31a	59412	Cup, gear shaft bearing, RH	1
32	59162	Cone, gear shaft bearing, LH	1
32a	59175	Cone, gear shaft bearing, RH	1
33	3897-T-1320	Clutch, gear shift	1
34	3891-E-1071	Shaft, gear	1
35	1246-X-284	Plunger, gear shift lock	3
36	2258-U-359	Spring, gear shift lock plunger	3
37	16X-211	Key, gear shaft	1
38	A-35828	Bevel Pinion & Gear Assy., 6.16/8.48	1
39	A-2843-Z-390	Push Rod Assy., shift operating	1
40	2849-H-216	Fork, gear shift	1
41	26X-71	Screw, gear shift fork	1
42	13X-53	Lock nut, gear shift fork screw	1
43	A2-2800-X-518	Carrier & Cap Assy., differential	1
44	10X-544	Capscrew, differential bearing cap	4
45	1820-T-46	Lock, differential veering adjusting ring	2
46	3X-159	Capscrew, differential bearing	2
47	S-2812-1	Capscrew, veering cage - LH	6
	S-2913-1	Capscrew, bearing cage - RH	6
48	1229-W-1505	Washer, bearing cage - capscrew	12
49	A-3838-K-193	Cage & Cup Assy., gear shaft bearing	1
50	2803-X-1818	Shim gear shaft bearing cage - .003	AR
	2803-Y-1819	Shim gear shaft bearing cage - .005	AR
	2803-P-2018	Shim gear shaft bearing cage - .010	AR

REAR AXLE WITH TWO-SPEED CARRIER
H-340 (Continued)

KEY NO.	PART NO.	PART NAME	QTY.
51	2214-W-49	Ring, differential bearing adjusting	1
51a	2214-W-49	Ring, differential bearing adjusting	1
52	1244-B-678	Spacer, differential bearing cup - .187	AR
	1244-C-679	Spacer, differential bearing cup - .192	AR
	1244-D-680	Spacer, differential bearing cup - .197	AR
	1244-E-681	Spacer, differential bearing cup - .202	AR
	1244-F-682	Spacer, differential bearing cup - .207	AR
	1244-G-683	Spacer, differential bearing cup - .212	AR
	1244-H-684	Spacer, differential bearing cup - .217	AR
52a	2803-N-846	Shim, gear shaft bearing - .003	AR
	2803-P-848	Shim, gear shaft bearing - .005	AR
	2803-Q-849	Shim, gear shaft bearing - .010	AR
53	3266-U-99	Cover, gear shaft bearing	1
54	2208-B-444	Gasket, carrier to housing	1
55	N-16	Nut, shift motor housing	2
56	1229-T-514	Washer, shift motor housing nut	2
57	3897-G-1319	Sleeve, chamber	1
58	2803-R-746	Shim, gear shift chamber	AR
	2803-S-747	Shim, gear shift chamber	AR
	2203-Z-1040	Shim, gear shift chamber	AR
59	2208-M-429		1
60	P-120	Plug, Oil Level	1
61	4X-835	Stud, shift chamber	2
67	1229-C-1511	Washer, carrier & housing stud nut	14
68	N-18	Nut, carrier & housing stud nut	14
69	HM-807046	Cone, pinion bearing - rear	1
70	HM-807010	Cup, pinion bearing - rear	1
71	2803-W-1141	Shim, pinion bearing - .187	AR
	2803-X-1142	Shim, pinion bearing - .189	AR
	2803-Y-1143	Shim, pinion bearing - .193	AR
	2803-Z-1144	Shim, pinion bearing - .197	AR
	2803-A-1145	Shim, pinion bearing - .201	AR
	2803-B-1146	Shim, pinion bearing - .205	AR
	2803-C-1147	Shim, pinion bearing - .207	AR
72	2803-R-850	Shim, pinion bearing cage - .003	AR
	2803-S-851	Shim, pinion bearing cage - .005	AR
	2803-T-852	Shim, pinion bearing cage - .010	AR
73	1850-V-48	Plug, pinion bearing cage	1
74	A-3826-Y-259	Cage & Cup Assy., bevel pinion bearing	1
75	HM-803110	Cup, bevel pinion bearing - Forward	1
76	HM-803145	Cone, bevel pinion bearing -Forward	1
77	A-1805-L-194	Oil Seal - Bevel Pinion Bearing	1
78	S-2913-1	Capscrew, pinion bearing cage	6
79	1229-W-1505	Washer, pinion bearing cage capscrew	6
80	1229-E-1331	Washer, drive pinion shaft	1
81	1827-B-80	Nut, drive pinion	1

REAR AXLE WITH TWO-SPEED CARRIER

L-345

KEY NO.	PART NO.	PART NAME	QTY.
1			
1	A7-3201-U-1581	Axle Housing Assembly	1
2	A-1199-P-1394	Axle Housing Breather	1
3	4-X-1050	Stud, Carrier to Housing (long)	4
4	4-X-1083	Stud, Carrier to Housing (short)	10
5	P-212	Plug, housing drain hole	1
6	2208-Y-441	Gasket, housing drain hole plug	3
7	2208-F-422	Gasket, axle shaft	4
8	3202-G-2971	Shaft, axle	2
9	1246-Z-234	Dowel, axle shaft	24
10	4X-759	Stud, hub & axle shaft	24
11	1229-U-515	Washer, axle shaft dowel shakeproof	24
12	N-17	Nut, axle shaft stud	24
13	42620	Cup, differential bearing - LH	1
13a	42620	Cup, differential bearing - RH	1
14	42688	Cone, differential bearing	1
14a	42688	Cone, differential bearing	1
15	15X-746	Bolt, Differential case - long	8
	15X-899	Bolt, Differential case - short	8
16	N-210-1	Nut, Differential case bolt	16
17	3892-D-1746	Gear, Helical Driven - Fast - 6.00	1
	3892-D-1746	Gear, Helical Driven - Fast - 5.63	1
18	3891-U-1087	Gear, Helical Drive Pinion - Fast - 6.00	1
	3891-U-1087	Gear, Helical Drive Pinion - Fast - 5.63	1
19	3892-X-1922	Gear, Helical Driven - Slow - 8.24	
	3892-X-1922	Gear, Helical Driven - Slow - 7.73	
20	3891-G-1229	Gear, Helical Drive Pinion - Slow - 8.24	
	3891-G-1229	Gear, Helical Drive Pinion - Slow - 7.73	
21	A-3835-J-348	Case Assembly Differential	1
22	1229-T-1034	Washer, Differential Side Gear Thrust	2
23	2234-F-266	Gear, Differential Side	2
24	3278-P-146	Spider, Differential	1
25	2233-Y-103	Pinion, Differential	4
27	1229-R-1032	Washer, Differential Pinion Thrust	4
28	RV-71017	Rivet, gear to case	8
29	S-278-D	Screw, drive gear lock plate	4
30	1829-F-6	Plate drive gear lock	2
31	HM-807010	Cup, gear shaft bearing - LH	
31a	HM-807010	Cup, gear shaft bearing - RH	1
32	HM-807040	Cone, gear shaft bearing - LH	1
32a	HM-807046	Cone, gear shaft bearing - RH	1
33	3897-A-1223	Clutch, Gear Shift	1
34	3891-G-1073	Shaft, Gear	1
35	1246-X-284	Plunger, Gear Shift	3
36	2258-U-359	Spring, Gear Shift Plunger	3
37	16X-211	Key, Gear Shaft	1
38	A-35564	Bevel Pinion & Gear Assembly - 6.00/8.24	1
	A-35566	Bevel Pinion & Gear Assembly - 5/63/7.73	1

REAR AXLE WITH TWO-SPEED CARRIER
L-345 (Continued)

KEY NO.	PART NO.	PART NAME	QTY.
39	A-2843-Z-390	Rod Assy., gear shift push rod	1
40	2849-K-219	Fork, gear shift	1
41	26X-71	Screw, shift fork	1
42	13X-53	Locknut, shift fork screw	1
43	A2-3800-B-522	Carrier and cap assembly	1
44	10X-544	Capscrew, differential bearing cap	4
45	1820-T-46	Lock, differential bearing adj. ring	2
46	3X-159	Capscrew, diff. bearing and adj. ring lock	2
47	S-2812-1	Capscrew, brg. cage, LH	6
	S-2913-1	Capscrew, brg. cage, RH	6
48	1229-W-1505	Washer, brg. cage capscrew	12
49	A-3838-M-195	Cage, gear shaft brg. - LH	1
50	2803-A-1821	Shim, gear shaft brg. cage - .003	AR
	2803-A-1822	Shim, gear shaft brg. cage - .005	AR
	2803-O-2019	Shim, gear shaft brg. cage - .010	AR
51	2814-W-75	Ring, diff. brg. adj.	2
51A			
52	1244-J-686	Spacer, diff. brg. cup - .187	AR
	1244-K-687	Spacer, diff. brg. cup - .192	AR
	1244-L-688	Spacer, diff. brg. cup - .197	AR
	1244-M-689	Spacer, diff. brg. cup - .202	AR
	1244-N-690	Spacer, diff. brg. cup - .207	AR
	1244-P-692	Spacer, diff. brg. cup - .212	AR
	1244-Q-693	Spacer, diff. brg. cup - .217	AR
52A	2803-N-846	Shim, gear shaft bearing cap - .003	3
	2803-P-848	Shim, gear shaft bearing cap - .005	2
	2803-Q-849	Shim, gear shaft bearing cap - .010	2
53	3266-U-99	Cover, gear shaft bearing	
54	2208-B-444	Gasket, carrier to housing	1
55	N-16	Nut, shift motor housing	2
56	1229-T-514	Washer, shift motor housing nut	2
57	3897-S-1319	Sleeve, chamber	1
58	2803-R-746	Shim, gear shift chamber - .005	AR
	2803-S-747	Shim, gear shift chamber - .010	AR
	2203-Z-1040	Shim, gear shift chamber - .030 (Solid)	AK
59	2208-T-280	Gasket, shift chamber	1
60	P-212	Plug, oil level	1
61	4X-835	Stud, shift chamber	2
62			
63			
64			
65			
66	S-2811	Capscrew, diff. carrier & housing - short (opt.)	10
	S-2817	Capscrew, diff. carrier & housing - long (opt.)	4
67	1229-C-1511	Washer, diff. carrier & housing capscrew	14
68	N-18	Nut, diff. carrier & housing stud	14
69	HM-813842	Core, pinion brg. cone rear	1
70	HM-813810	Cup, pinion brg. cone - rear	

REAR AXLE WITH TWO-SPEED CARRIER

L-345

(Continued)

KEY NO.	PART NO.	PART NAME	QTY.
71	2203=L-2014	Shim, drive pinion brg. .199	AR
	2203=M-2015	Shim, drive pinion brg. .200	AR
	2203=N-2016	Shim, drive pinion brg. .201	AR
	2203=P-2018	Shim, drive pinion brg. .202	AR
	2203=Q-2019	Shim, drive pinion brg. .203	AR
	2203=R-2020	Shim, drive pinion brg. .204	AR
	2203=S-2021	Shim, drive pinion brg. .210	AR
	2203=T-2022	Shim, drive pinion brg. .216	AR
	2203=U-2023	Shim, drive pinion brg. .222	AR
	2203=V-2024	Shim, drive pinion brg. .228	AR
	2203=W-2025	Shim, drive pinion brg. .234	AR
	2203=X-2026	Shim, drive pinion brg. .240	AR
72	2803-A-807	Shim, pinion bearing cage - .003	AR
	2803-B-808	Shim, pinion bearing cage - .005	AR
	2803-Y-2001	Shim, pinion bearing cage - .010	AR
73	1850-V-48	Plug, bevel pinion brg. cage	1
74	A-3826-A-261	Cage, pinion brg.	
75	HM-804810	Cup, pinion brg. - Forward	
76	HM-804843	Cone, pinion brg. - Forward	1
77	A-1805-B-80	Oil Seal, Pinion	1
78	S-2913-1	Capscrew, pinion brg. cage	6
79	WA-19	Washer, pinion brg. cage capscrew	6
80	1229-P-1030	Washer, pinion shaft	1
81	14-X-57	Nut, drive pinion	1

REAR AXLE HYDRAULIC BRAKES
H-140-DH-X-58

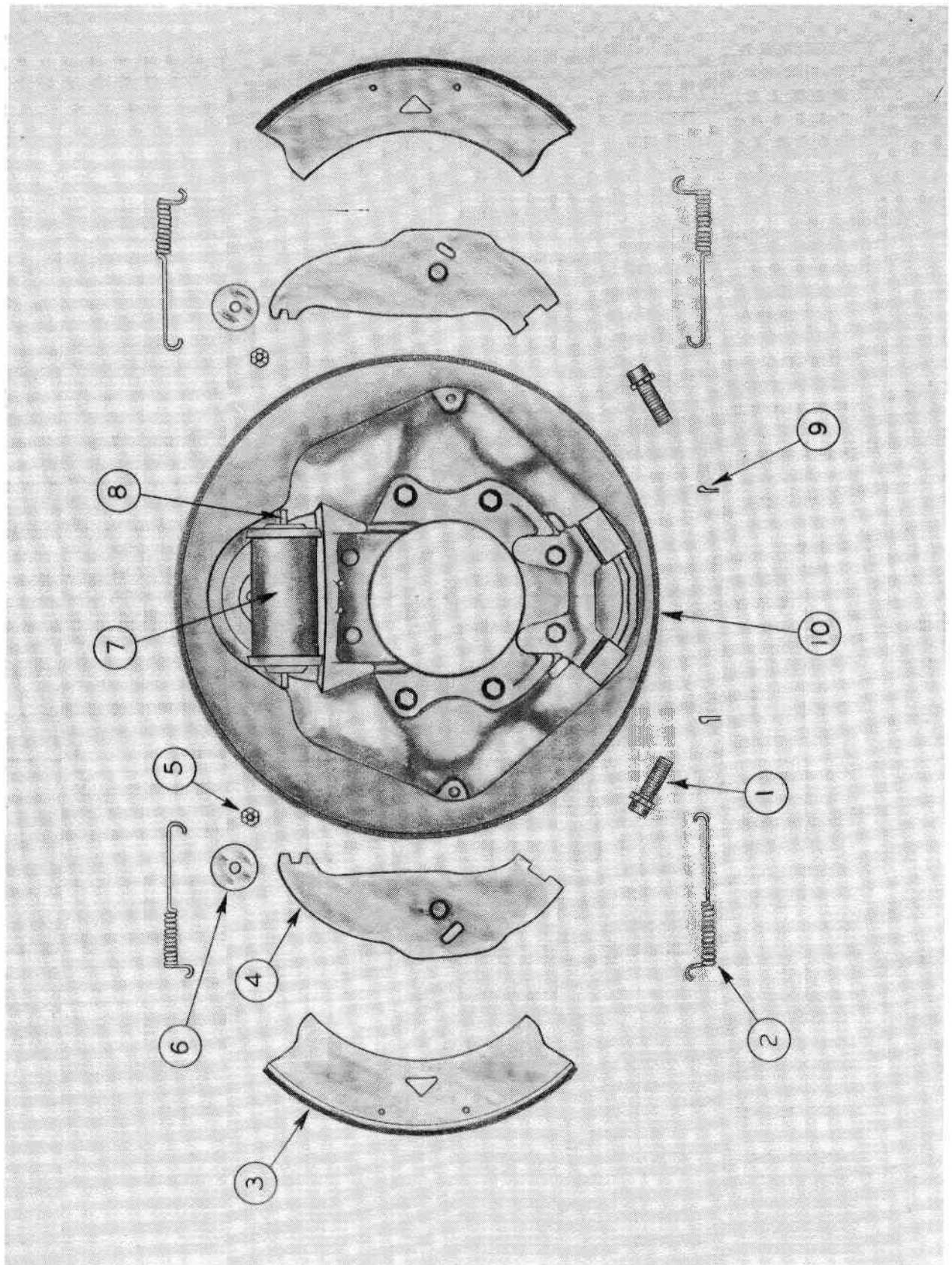

REAR AXLE HYDRAULIC BRAKES
H-140-DH-X-58

<u>KEY NO.</u>	<u>PART NO.</u>	<u>PART NAME</u>	<u>QTY.</u>
1	1779-Z-78	Brake adjusting bolt	4
2	2758-Q-17	Brake shoe spring	8
3	A6-3722-S-123	Brake shoe and lining assembly	4
	A-3722-S-123	Shoe only	
4		Brake lever assembly	
	A-372-G-59	LH forward & RH reverse	2
	A-1-372-G-59	RH forward & LH reverse	2
5	N-56	Brake lever and shoe guide bolt nut	4
6	1729-Q-225	Brake lever and shoe guide bolt washer	4
7	A6-3261-N-40	Wheel cylinder assembly	2
8	1745-B-28	Wheel cylinder push rod	4
9	K-237	Brake lever and shoe guide bolt cotter key	4
10	A-3736-D-160	Backing plate and brake spider assembly	2

REAR AXLE AIR BRAKES

H-140-P-X-31

L-148-P-X-1

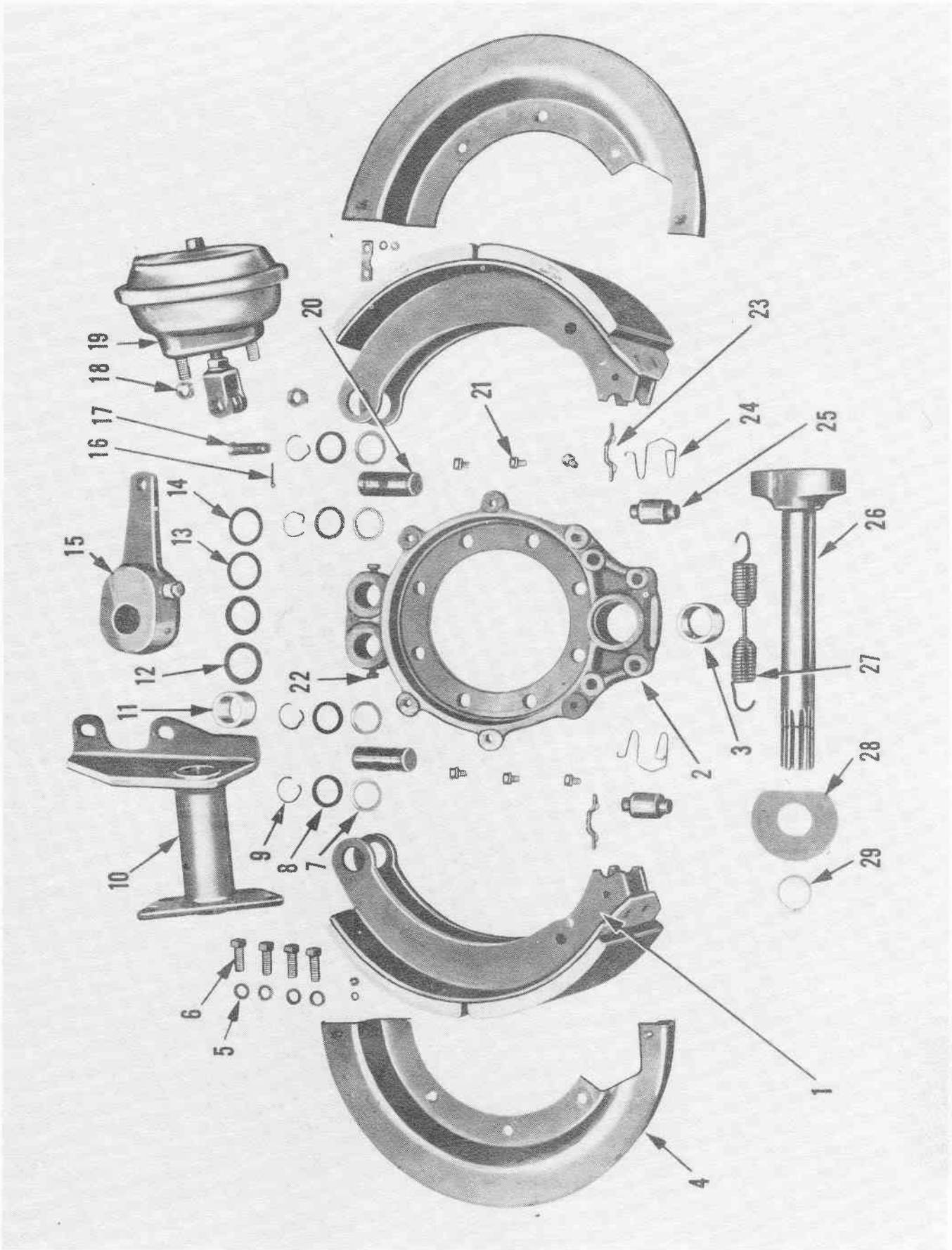

REAR AXLE AIR BRAKES
H-140-P-X-31

KEY NO.	PART NO.	PART NAME	QTY.
1	A14-3722-D-82 (Primary)	Brake Shoe and Liner Assembly	2
	A15-3722-D-82 (Secondary)	Shoe Only - A-3722-D-82)	2
2	A1-3211-H-1230	Brake Spider (Included Bushing)	2
3	1225-N-376	Spider Cam Nylon Bushing	2
4	A1-3236-M-1079	Dust Shield Segment	2
5	WA-18	Chamber Bracket Cap Screw Washer	8
6	S-1812-	Chamber Bracket Cap Screw	8
7	1205-K-193	Anchor Pin felt retainer	8
8	5X-640-	Anchor Pin Felt	8
9	1218-M-13-	Anchor Pin Lock Ring	8
10	A1-3299-R-1552	LH Chamber Bracket	1
	A1-3299-S-1553	RH Chamber Bracket	1
11	1225-N-378	Chamber Bracket Nylon Bushing	2
12	5X-191-	Cam Spacing Washer Felt	4
13	1229-R-122	Cam Spacing Washer (Thin)	2
14	1229-Q-771	Cam Spacing Washer (Thick)	2
15	A2-3275-G-501	Slack Adjuster	2
16	K-248	Chamber Clevis Pin Cotter Key	2
17	19X-41	Chamber Clevis Pin	2
18	5/8 - 18 NF Hex Nut - Thin	Chamber Attaching Stud Nut	4
19	F5-3276-T-20	Air chamber assembly	2
20	1759-M-13	Shoe Anchor Pin	4
21	A-2X-19	Dust Shield Attaching Cap Screw	12
22	S-265-D	Anchor Pin Lock Screws	4
23	1218-G-85	Shoe Return Spring Pin	4
24	1718-Y-103	Shoe Roller Attaching Spring Clip	4
25	1779-R-18	Shoe Roller (Cam Follower)	4
26	2210-K-3027	LH Cam	1
	2210-L-3028	RH Cam	1
27	2258-P-354	Shoe Return Spring	2
28	1229-L-844	Cam Head Flat Washer	2
29	1229-Z-1118	Cam Groove Lock Ring	2

REAR AXLE AIR BRAKES
L-148-P-X-1

KEY NO.	PART NO.	PART NAME	QTY.
1	A23-3722-N-66 (Primary)	Brake Shoe and Liner Assembly	2
	A24-3722-N-66 (Secondary)	(Shoe Only - A-3722-N-66)	4
2	A1-3211-N-1210	Brake Spider	2
3	1225-N-378	Spider Cam Nylon Bushing	2
4	Does not apply to "L"axle	Dust Shield Segment	
5	WA-18	Chamber Bracket Cap Screw Washer	8
6	S-2812-	Chamber Bracket Cap Screw	8
7	1205-K-193	Anchor Pin Felt Retainer	8
8	5X-640-	Anchor Pin Felt	8
9	1205-K-193	Anchor Pin Lock Ring	8
10	A1-3299-S-1553	RH Chamber Bracket	1
	A1-3299-R-1552	LH Chamber Bracket	1
11	1225-N-378	Chamber Bracket Nylon Bushing	2
12	5X-191-	Cam Spacing Washer Felt	4
13	1229-R-122	Cam Spacing Washer (Thin)	2
14	1229-Q-771	Cam Spacing Washer (Thick)	2
15	A3-3275-G-501	Slack Adjuster	2
16	K-248	Chamber Clevis Pin Cotter Key	2
17	19X-41	Chamber Clevis Pin	2
18	5/8-18 NF-Hex Nut-Thin	Chamber Attaching Stud Nut	4
19	F5-3276-X-24	Air chamber assembly	2
20	1759-M-13	Shoe Anchor Pin	4
21	Does not apply to "L"axle	Dust Shield attaching cap screw	
22	S-265-D	Anchor Pin Lock Screws	4
23	1218-G-85	Shoe Return Spring Pin	4
24	1718-Y-103	Shoe Roller Attaching Spring Clip	4
25	1779-R-18	Shoe Roller (Cam Follower)	4
26	2210-K-3027	RH Cam	1
	2210-L-3028	LH Cam	
27	2250-P-354	Shoe Return Spring	2
28	1229-L-844	Cam head flat washer	2
29	1229-Z-1118	Cam Grove Lock Ring	2

REAR AXLE HUES AND DRUMS

H-140-DH-X-58

H-140-P-X-31

L-148-P-X-1

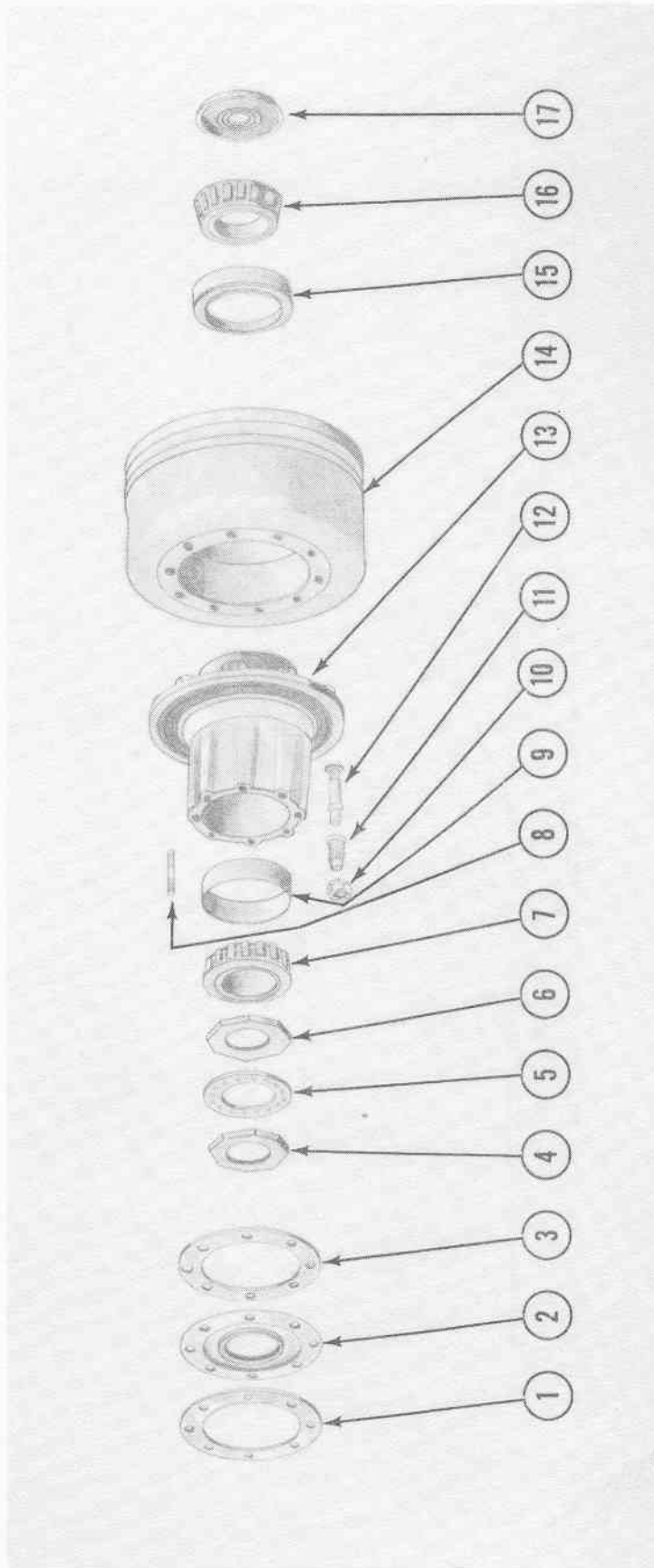

REAR AXLE HUBS AND DRUMS

H-140-DH-X-58

H-140-P-X-31

KEY NO.	PART NO.	PART NAME	QTY.
1	2208-J-426	Gasket, Axle Shaft	2
2	A-1205-P-614	Oil Seal, Wheel Bearing - Outer	2
3	2208-J-426	Gasket, Axle Shaft	2
4	1227-T-228	Nut, Wheel Gearing, Outer	2
5	1229-G-1021	Washer, wheel gearing nut	2
6	1227-T-540	Nut, wheel bearing adjustment	2
7	3984	Cone, wheel bearing, outer	2
8	4X-356	Stud, hub & axle shaft	16
9	3920	Cup, wheel bearing, outer	2
10	1199-M-117	Nut, hub & drum stud cap - outer, LH	10
	1199-N-118	Nut, hub & drum stud cap - outer, RH	10
11	1199-K-115	Nut, hub & drum stud cap - inner LH	10
	1199-J-114	Nut, hub & drum stud cap - inner RH	10
12	20X-207	Stud, hub & wheel stud - LH	10
	20X-206	Stud, hub & wheel stud - RH	10
13	A-333-D-680	Hub & cup assembly	2
14	3219-S-1995	Drum, brake	2
15	493	Cup, wheel bearing - Inner	2
16	495-AX	Cone, wheel bearing, inner	2
17	A-1205-B-574	Oil Seal, wheel bearing, inner	2

REAR AXLE HUBS AND DRUMS

H-148-P-X-1

KEY NO.	PART NO.	PART NAME	QTY.
1	2208-F-422	Gasket, axle shaft	2
2	A-1205-Q-615	Oil Seal, Wheel Bearing, Outer	2
3	2208-F-422	Gasket, Axle shaft	2
4	1227-H-346	Nut, wheel bearing, outer	2
5	1229-R-1058	Washer, wheel bearing nut	2
6	1227-V-516	Nut, wheel bearing adjusting	2
7	42687	Cone, wheel bearing - outer	2
8	4X-759	Stud, hub & axle shaft	24
9	42620	Cup, wheel bearing - outer	2
10	1199-M-117	Nut, hub & wheel stud cap - LH outer	10
	1199-N-118	Nut, hub & wheel stud cap - RH outer	10
11	1199-K-115	Nut, hub & wheel stud, cap - LH inner	10
	1199-J-114	Nut, hub & wheel stud, cap - RH inner	10
12	20X-207	Stud, hub & wheel - LH	10
	20X-206	Stud, hub & wheel - RH	10
13	A-333-X-778	Hub & cup assembly	2
14	3219-T-1658	Drum, brake	2
15	653	Cup, wheel bearing - Inner	2
16	663-A	Cone, wheel bearing - inner	2
17	A-1205-J-634	Oil Seal, wheel Bearing - inner	2

Diagram, air brake assembly

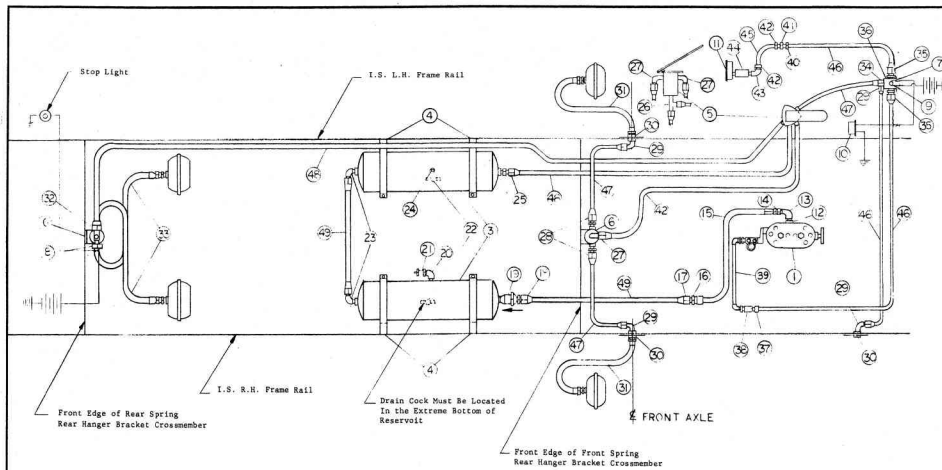

NOTE: Before Treadle Valve Assembly, Item 5, is positioned on chassis, rotate valve assembly body 120° counterclockwise with reference to the Treadle Assembly. This is done to allow the valve body fittings to clear the steering gear angle.

The Low Pressure Indicator, Item 9, must be inserted in the extreme bottom of Junction Block.

The remaining fitting, Items 29, 34, 35 must be inserted in the upper pipe taps of the Junction Block.

The remaining hole to carry Pipe Plug, Item 36 Arrow on Single Check Valve, Item 19, must be positioned as shown.

The Quick Release Valves must be assembled to chassis with exhaust ports down.

Buzzer Item #10, must be located on the lower dash panel.

Air Gauge Item #11 must be located on the instrument panel.

ITEM NO.	QUANTITY	PART NUMBER	ITEM	VENDOR	DESCRIPTION
1	1		Compressor		12 Cubic Foot
2	1		Drive Detail Kit		Not Shown
3	2	228707	Reservoir	Bendix-Westinghouse	8" x 26" - 1240 cu. in.
4	4	205093	Reservoir Bracket	Bendix-Westinghouse	
5	1	225834	Treadle Valve	Bendix-Westinghouse	Type E
6	2	205000	Quick Release Valve	Bendix-Westinghouse	3/8" Pipe Tap Supply
7	1	212322	Manifold Fitting (Junction Block)	Bendix-Westinghouse	1 - 3/8" Pipe Tap, 7 - 1/4" Pipe Taps
8	1	227400	Stop Light Switch	Bendix-Westinghouse	3/8" Pipe Thread
9	1	228750	Low Pressure Indicator	Bendix-Westinghouse	1/4" Pipe Threads
10	1	RHM-6355-1	Buzzer	R.B.M. Division	12 Volt
11	1	SM-368-D	Air Gauge	Stewart Warner	1/8" Pipe Threads
12	1	213042	Discharge Fitting	Bendix-Westinghouse	1/2" Pipe Tap (Use with 8-W Compressors)
13	1	49x10	Elbow, 90° Male	Weatherhead	1/2" Pipe Threads x 5/8" O.D. Tube
14	1	HA08-10WS	Female 45° Flare Swivel	Imperial Eastman	5/8" O.D. Tube x 1/2" I.D. Hose
15	1	D410	Hose, Compressor	Imperial Eastman	1/2" I.D. x 59/64" O.D.
16	1	HA08-10MJ	Male 37° Flare	Imperial Eastman	5/8" O.D. Tube x 1/2" I.D. Hose
17	1	1110x10	Nut, Flare	Weatherhead	5/8" O.D. Tube
18	1	216684	Connector	Bendix-Westinghouse	1/2" Pipe Threads x 5/8" O.D. Tube
19	1	227866	Single Check Valve	Bendix-Westinghouse	1/2" Male Pipe x 1/2" Female Pipe
20	1	233569	Street El	Bendix-Westinghouse	3/8" Pipe Threads x 3/8" Pipe Tap
21	1	223444	Safety Valve	Bendix-Westinghouse	3/8" Pipe Threads
22	2	215310	Drain Cock	Bendix-Westinghouse	1/4" Pipe Threads
23	2	221825	Elbow 90° Male	Bendix-Westinghouse	1/2" Pipe Tap x 5/8" O.D. Tube
24	1		Plug, Pipe		3/8" Pipe Threads
25	1	217691	Connector	Bendix-Westinghouse	1/2" Pipe Threads x 1/2" O.D. Tube
26	1	215703	Te	Bendix-Westinghouse	3/8" Pipe Threads x 1/2" O.D. Tube x 3/8" O.D. Tube
27	3	215709	Elbow 90° Male	Bendix-Westinghouse	3/8" Pipe Threads x 1/2" O.D. Tube
28	2	205053	Connector	Bendix-Westinghouse	1/4" Pipe Threads x 3/8" O.D. Tube
29	4	205102	Elbow 90° Male	Bendix-Westinghouse	1/4" Pipe Threads x 3/8" O.D. Tube
30	*2	205465	Anchor Coupling	Bendix-Westinghouse	1/4" Pipe Tap - Both Ends
31	2	228545	Hose, Front Brake Chamber	Bendix-Westinghouse	3/4" O.D. x 3/8" I.D. x 25 1/8" Long
32	1	227900	Te	Bendix-Westinghouse	3/8" Pipe Tap x 3/8" Pipe Threads x 1/2" O.D. Tube
33	2	228557	Hose, Rear Brake Chamber	Bendix-Westinghouse	3/4" O.D. x 3/8" I.D. x 38 1/8" Long
34	1	205824	Connector	Bendix-Westinghouse	3/8" Pipe Threads x 3/8" O.D. Tube
35	2	205183	Connector	Bendix-Westinghouse	1/4" Pipe Threads x 1/4" O.D. Tube
36	4	230576	Plug, Pipe	Bendix-Westinghouse	1/4" Pipe Threads
37	1	105x4	Standard Nut	Weatherhead	1/4" O.D. Tube
38	1	300x4	Union	Weatherhead	1/4" O.D. Tube
39	1	223913	Hose, Governor	Bendix-Westinghouse	1/4" O.D. Tube
39	1	737038-80404-05000	Hose, Governor	Weatherhead	1/4" O.D. Tube (Used with Ford 332, 332A)
40	1	66x4	Female Connector	Weatherhead	1/4" O.D. Tube x 1/8" Pipe Tap
41	1	6200x3	Male Connector	Weatherhead	3/16" Tube x 1/8" Pipe
42	2	6100x3	Nut	Weatherhead	3/16" Tube
43	1	6400x3	Male Elbow	Weatherhead	3/16" Tube x 1/8" Pipe
44	1	3300x2	1/8" Pipe Coupling (Brass)	Weatherhead	1/8" Pipe
45	1	0922	Tubing, Nylon-Seal "E"	Imperial Eastman	3/16" O.D. x 1/8" I.D. - 12" Long
46			Tubing, Dead Soft Annealed Copper		1/4" O.D. x .030 Wall Thickness
47			Tubing, Dead Soft Annealed Copper		3/8" O.D. x .032 Wall Thickness
48			Tubing, Dead Soft Annealed Copper		1/2" O.D. x .032 Wall Thickness
49			Tubing, Dead Soft Annealed Copper		5/8" O.D. x .035 Wall Thickness

INACTIVE NOS. 24 903 20251
 REPLACED BY NOS.

BLUE BIRD BODY CO.

ZAGREB AIR BRAKE ASSY

10 25311

DZBEMERIS

*3/4 Air Entrance Door

Form #BBC-65-IV-33
January 4, 1965

NOTE: Item 16 Male 37° Flare Fitting used in lieu of Male 45° Flare Fitting which is not available. Eastern Atlantic advises that this is common practice and will cause no trouble.

DIAGRAM, AIR RESERVOIR TANK & RELAY VALVE, TANDEM BB CHASSIS

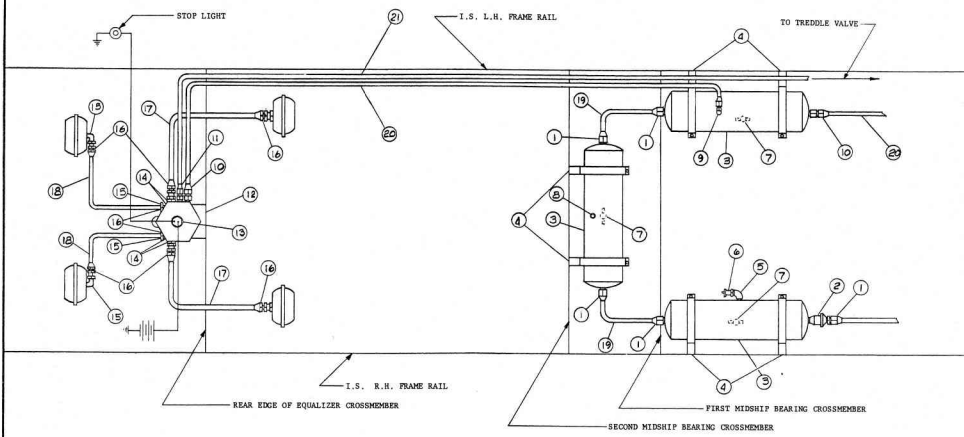

ITEM NO.	QUANTITY	PART NO.	ITEM	VENDOR	DESCRIPTION
1	5	216684	Connector	Bendix Westinghouse	1/2" Pipe Threads x 5/8" O.D. Tube
2	1	227866	Single Check Valve	Bendix Westinghouse	1/2" Male Pipe x 1/2" Female Pipe
3	3	228707	Reservoir	Bendix Westinghouse	8" x 26" - 1240 cu. in.
4	6	205093	Reservoir Bracket	Bendix Westinghouse	
5	1	233569	Street Elbow	Bendix Westinghouse	3/8" Pipe Threads x 3/8" Pipe Tap
6	1	223444	Safety Valve	Bendix Westinghouse	3/8" Pipe Threads
7	3	215310	Drain Cock	Bendix Westinghouse	1/4" Pipe Threads
8	1		Pipe Plug		3/8" Pipe Threads
9	1	215709	Elbow	Bendix Westinghouse	3/8" Pipe Threads x 1/2" O.D. Tube
10	2	217691	Connector	Bendix Westinghouse	1/2" Pipe Threads x 1/2" O.D. Tube
11	1	205053	Connector	Bendix Westinghouse	1/4" Pipe Threads x 3/8" O.D. Tube
12	1	229467	2-5 Relay Valve	Bendix Westinghouse	
13	1	226262	Stoplight Switch	Bendix Westinghouse	1/4" Pipe Threads
14	4	212862	Reducing Bushing	Bendix Westinghouse	1/4" Pipe Tap x 3/8" Pipe Threads
15	4	233588	90° Street Elbow	Bendix Westinghouse	1/4" Pipe
16	8	215540	Hose Connector	Bendix Westinghouse	1/4" Pipe Thread x BW-101-W Hose
17	2	BW-101-W	Brake Chamber Hose (Drive Axle)	Bendix Westinghouse	3/4" O.D. x 3/8" I.D. x 31" Long
18	2	BW-101-W	Brake Chamber Hose (Trailing Axle)	Bendix Westinghouse	3/4" O.D. x 3/8" I.D. x 24" Long
19	-		Tubing, Dead Soft Annealed Copper		5/8" O.D. x .035 Wall Thickness
20	-		Tubing, Dead Soft Annealed Copper		1/2" O.D. x .032 Wall Thickness
21	-		Tubing, Dead Soft Annealed Copper		3/8" O.D. x .032 Wall Thickness

INACTIVATE NOS.
REPLACED BY NOS.

REV. NO.	DATE	DESCRIPTION
1	7-28-65	REVISED TO SHOW CHANGES TO BLUE BIRD BODY CO. PART VALVE, TROUBLE VALVE, AND RELAY VALVE, TANDEM RETURN
2		
3		
4		
5		
6		
7		
8		
9		
10		
11		
12		
13		
14		
15		
16		
17		
18		
19		
20		
21		
22		

25632