

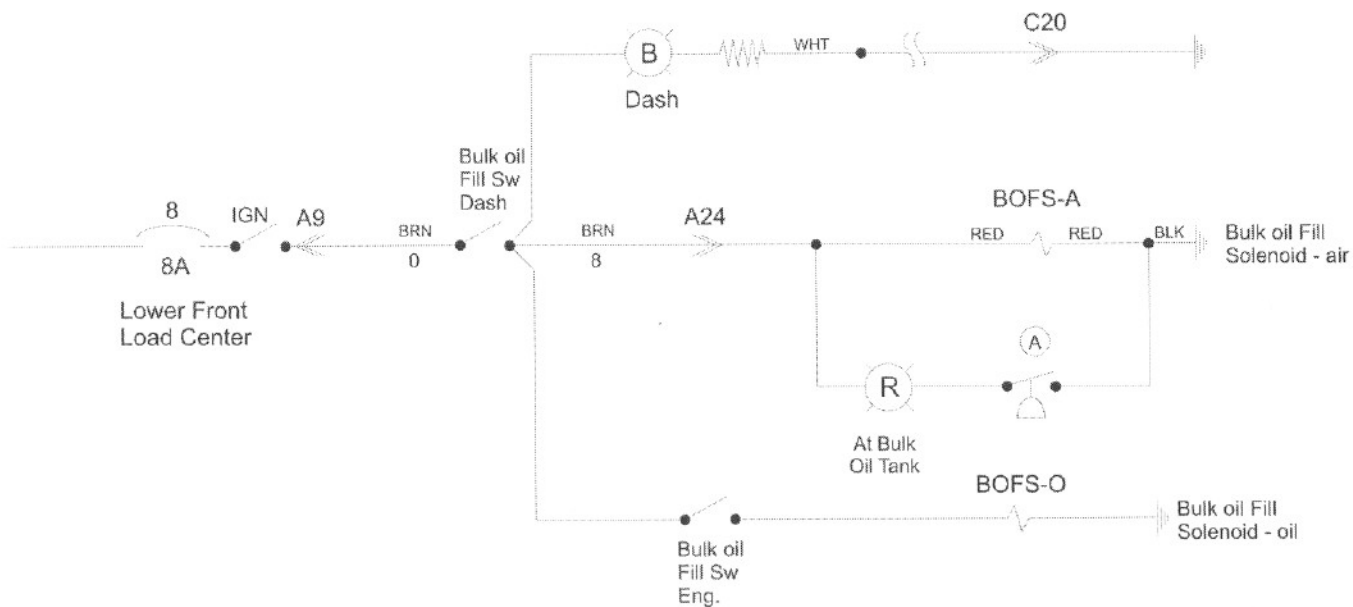

1984 Wanderlodge FC

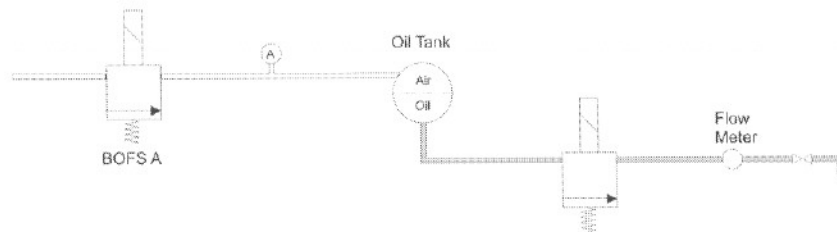

To BE CHECKED

(A) Air Pressure Switch Located on Bulk Oil Tank

1904-021	Compressed air system	
Reference	Description	
BBC	L. Scott	W. Schreurs
DESIGN	DRAWN	CHECKED

Bulk Oil System

BLUEBIRD WANDERLODGE CO.
FORT VALLEY GEORGIA U.S.A.
1984 F.C.35 SB

Nov.11, 2007	1	Added bulk oil fill solenoid & Added air/oil system
Date	Revision	Description

DWG NO 1984-002 Rev1

To Be Installed

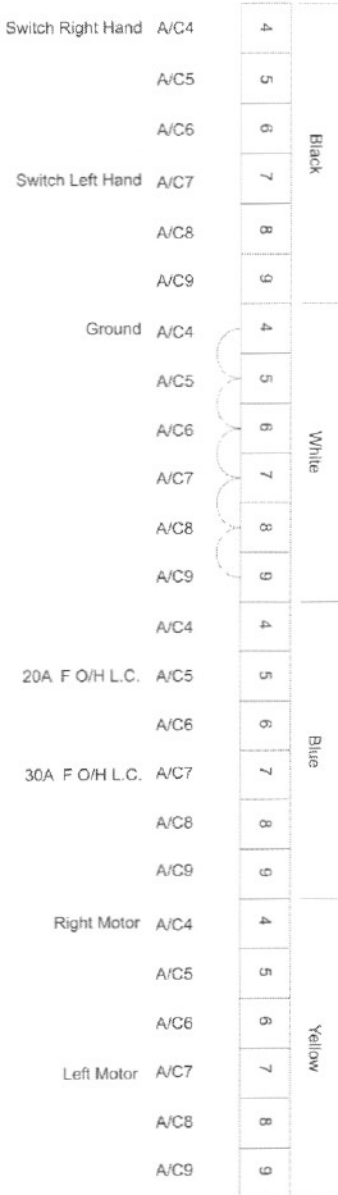

Date	Revision	Description

Reference Description
 B9C L. Scott W. Schreurs
 DESIGN DRAWN CHECKED

Dash Air Conditioning Wiring Diagram

BLUEBIRD WANDERLodge CO
 PART DIVISION
 1984 F.C.55 SB

DWG NO 1984-003A

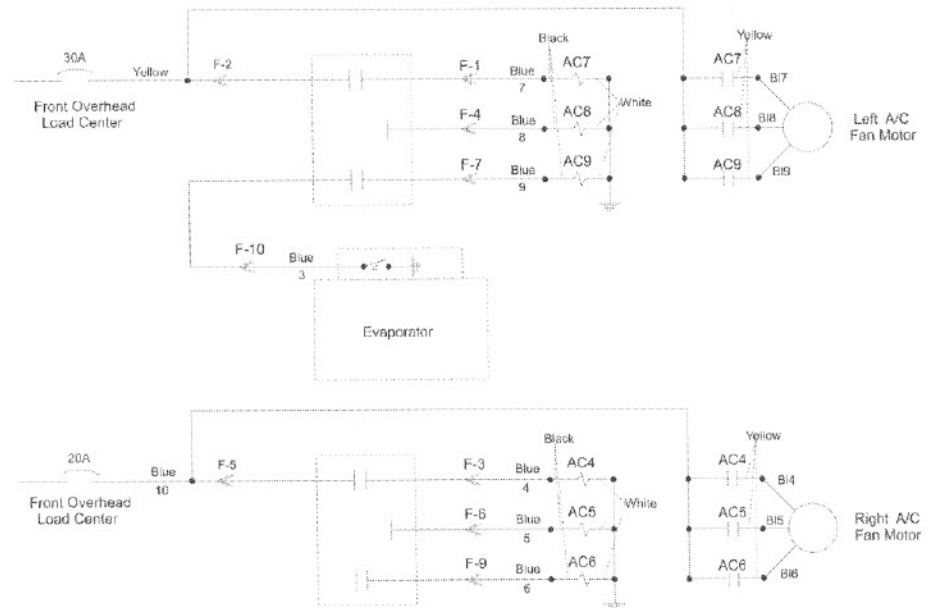

Install new bosch type relays - AC4, AC5, AC6, AC7 & AC9 to reduce load on A/C Switches

Reference	Description	
BBC	L. Scott	W. Schreurs
DESIGN	DRAWN	CHECKED
Dash Air Conditioning		
BLUEBIRD WANDERLODGE CO. FORT VALLEY GEORGIA U.S.A. 1984 F.C.35 SB		
DWG NO	1984-003 Rev1	

Date	Revision	Description
Nov. 10, 2007	1	Modified wiring & added wire color

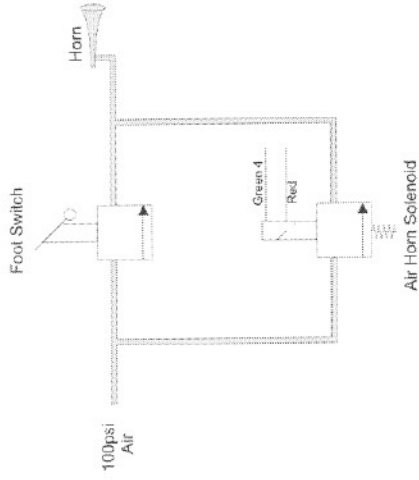
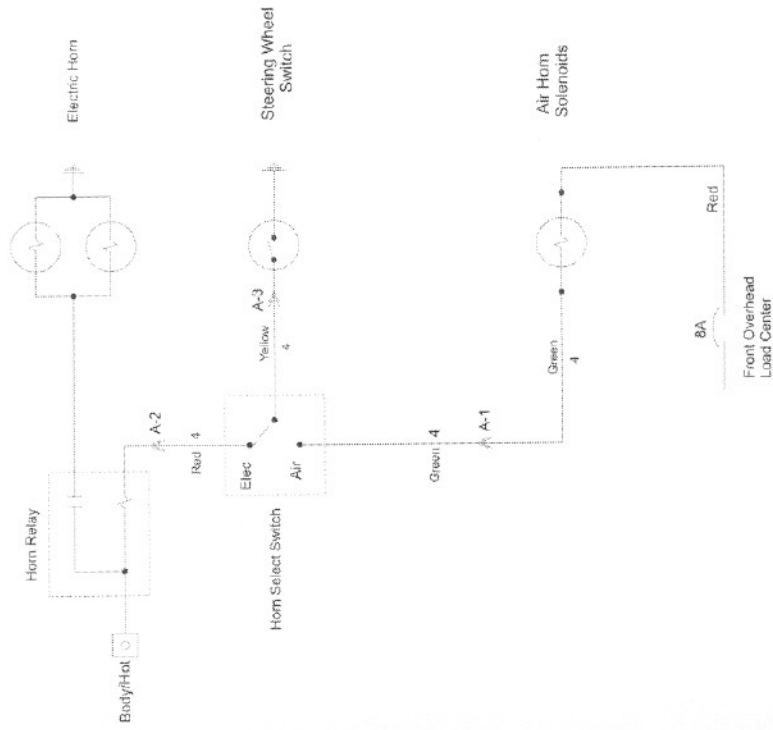

Reference	Description
BBC	L. Scott W. Schreurs
DESIGN	DRAWN
	CHECKED

**Air / Elect
Horns**

BLUEBIRD WANDERLODGE CO.
FORT VALLEY GEORGIA U.S.A.
1964 F.C. 35 SB

DWG NO 1984-004 Rev1

Date	Revision	Description
Nov 11, 2007	1	Removed Elec. Foot switch, Removed electric Air Horn Solenoid, Added Air System

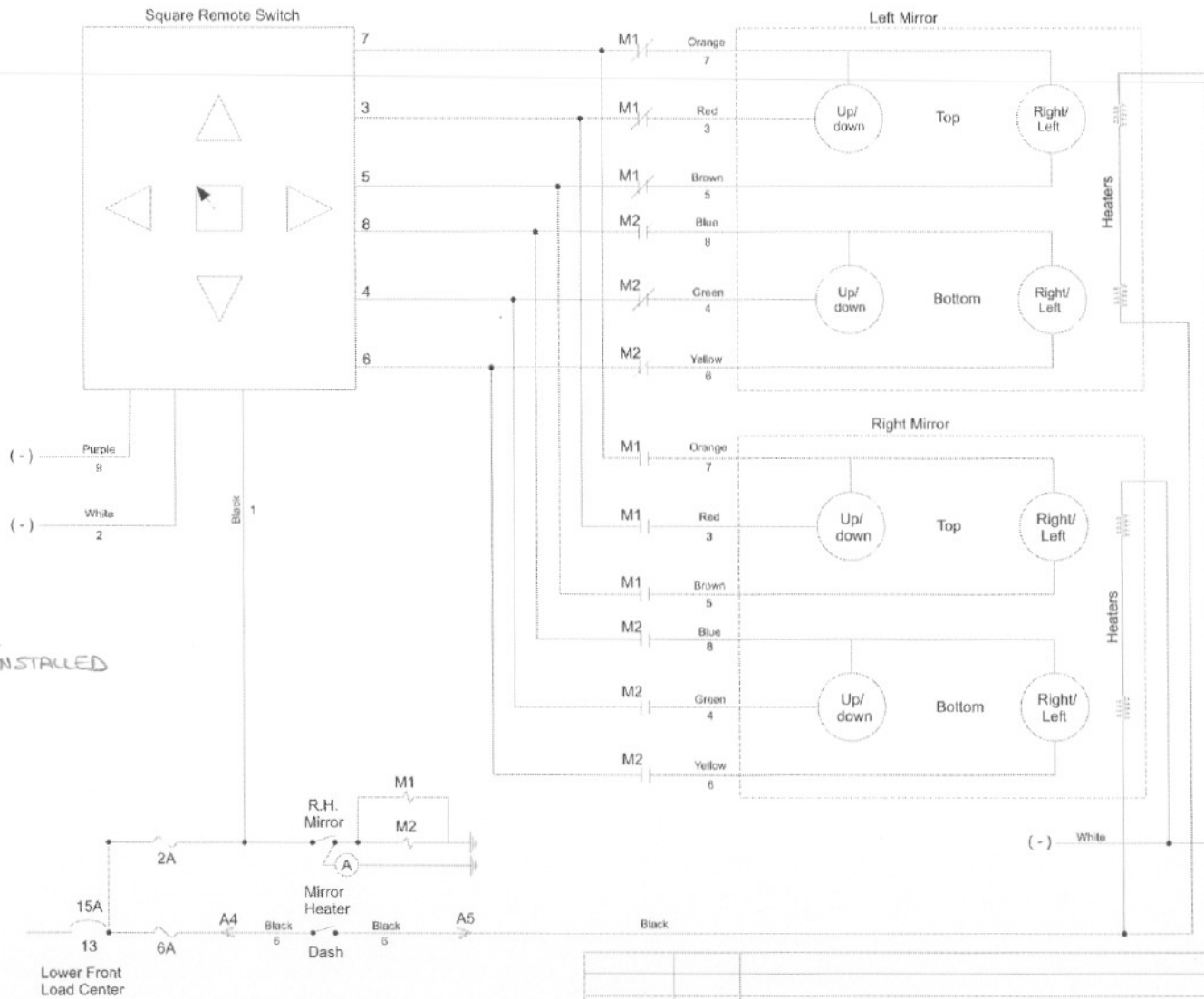

To BE INSTALLED

Reference	Description	
BBC	L. Scott	W. Schreurs
DESIGN	DRAWN	CHECKED
Electric Mirrors		
BLUEBIRD WANDERLODGE CO. FORT VALLEY GEORGIA U.S.A. 1964 F.C. 35 SB		
DWG NO 1984-005		

Date	Revision	Description

20A
2

Yellow



Lower Front Load Centre

Reference	Description
BBC	L. Scott W. Scheilus
DESIGN	DRAWN
	CHECKED

Air Dryer

BLUEBIRD WANDERLodge CO.
FORT VALLEY GEORGIA U.S.A.
1984 F.C. 35 SB

DWG NO 1984-006

Date	Revision	Description

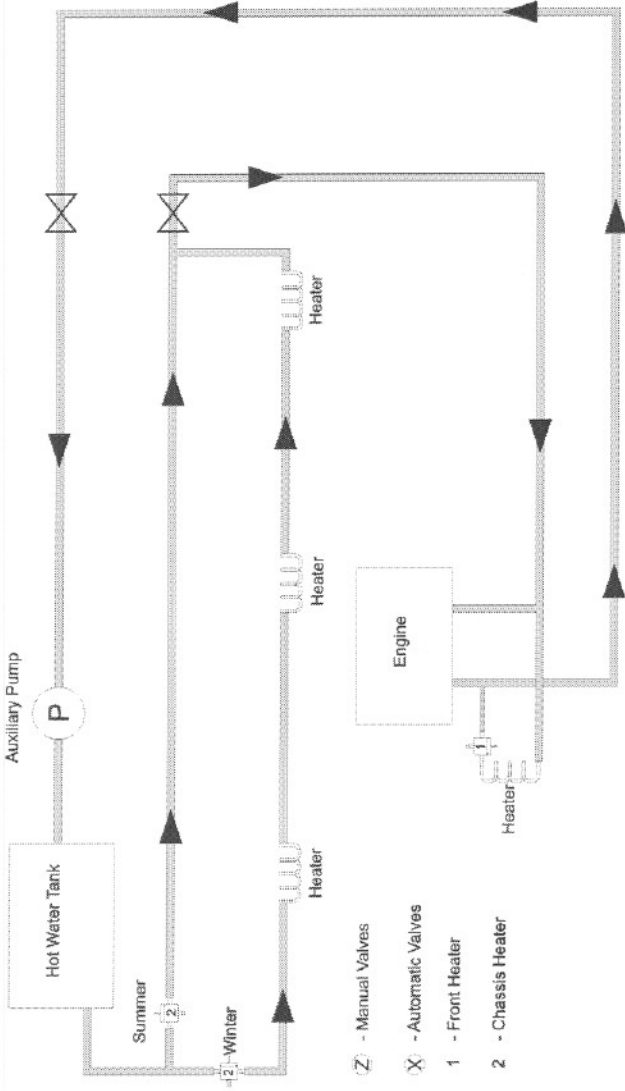

- (Z) - Manual Valves
- (X) - Automatic Valves
- 1 - Front Heater
- 2 - Chassis Heater

Reference	Description
BBC	L. Scott
DESIGN	W. Schreurs
	DRAWN
	CHECKED

Chassis / Heat
 Mechanical
 (Page 2 of 3)

BLUEBIRD VANDERLODGE CO.
 PORT HANCOCK, ALASKA
 1984 F.C. 35 SB

DWG NO 1984-008A Rev 1

Date	Revision	Modified Symbols	Description
Nov. 10, 2007	1		

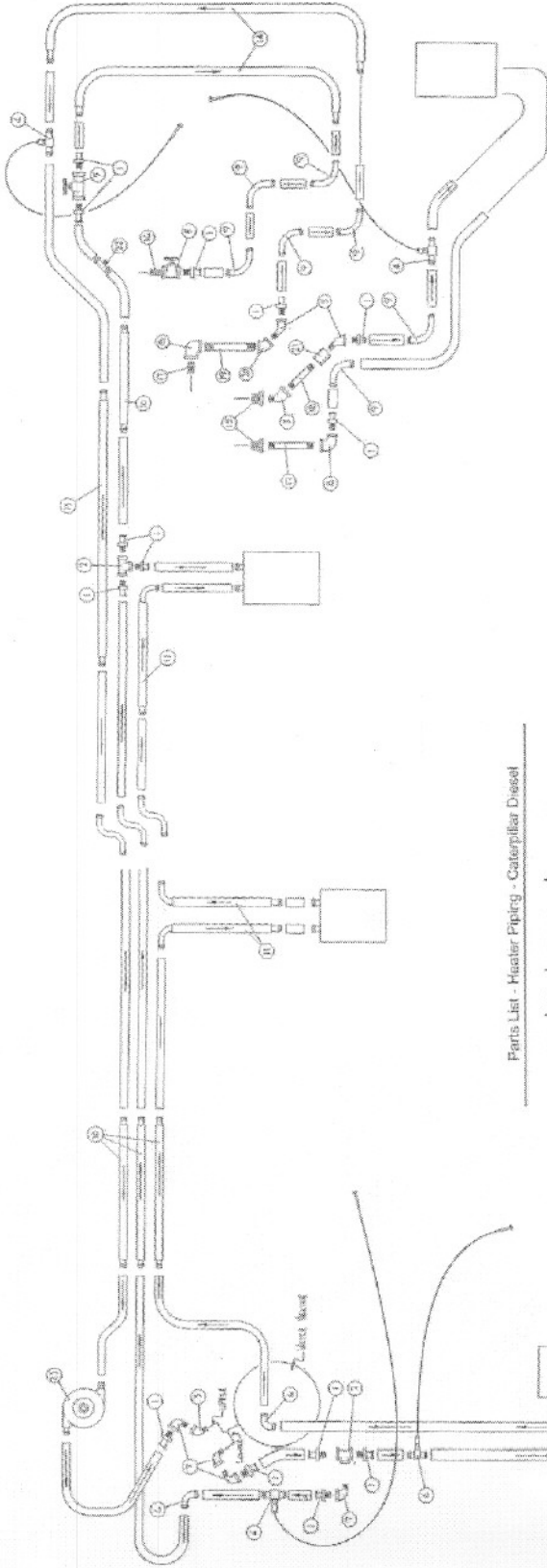

Parts List - Heater Piping - Caterpillar Diesel

Item	Qty	Part No.	Description
1	14	0319200	Adapter, 3/4" NPTX1" Hose
2	2	0535518	Tee, 3/4" FDP, Galv.
3	4	2217040	St. Elb. 3/4" x 45, Galv
4	4	0651844	Valve (RTCO) #2606
5	2	2052512	Valve, Gate, 3/4" Brass
6	2	0231303	Elbow, Brass Pipe 90
7	4	2016653	St. Elb. 3/4" x 90, Galv
8	2	2009207	Elbow, 3/4" x 90, Galv
9	7	0606834	Elbow, Brass Pipe, Long 90
10	4	0756049	Pipe, Wheel Housing, Rear Heating system
11	3	0357715	Pipe, Rear Heating System, Intermediate
12	3	0817189	Tubing, Rear Heaters, W/L
13	1	0756031	Pipe, Pressure Line, Rear Heating System
14	2	0658245	Tubing, Cross-Over, Cat. Heating System
15	2	2009082	Pipe Bushing, 3/4" x 1"
16	1	2009538	Nipple, 3/4" x 4" Galv. Pipe
17	2	2009512	Nipple, 3/4" x 2" Galv. Pipe
18	1	2009520	Nipple, 3/4" x 3" Galv. Pipe
19	1	2009563	Nipple, 3/4" x 8" Galv. Pipe
20	1	2009199	Elbow, 3/4" x 45 Galv. Pipe
21	1	2009132	Coupling, Pipe 3/4"
22	1	0279075	Tubing Assembly, Bleeder
23	1	0252023	Pump, Aux, Diesel W/L

Reference	Description
BBC	L. Scott
023628	W. Schreurs
	DR3294
	CHECKED

Chassis Heater
Parts List
(Page 3 of 3)

BLUEBIRD WANDERLodge CO.
FORT VALLEY, GEORGIA, U.S.A.
1984 F.C. 35 SB

DWG NO 1984-008B

Date	Revision	Description

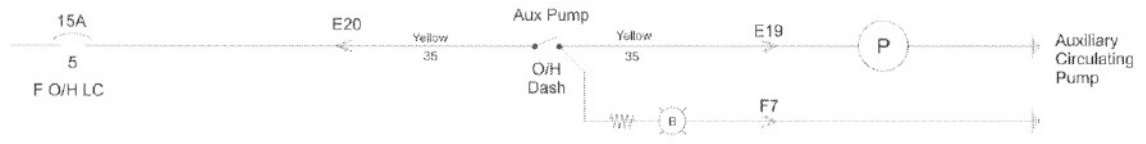
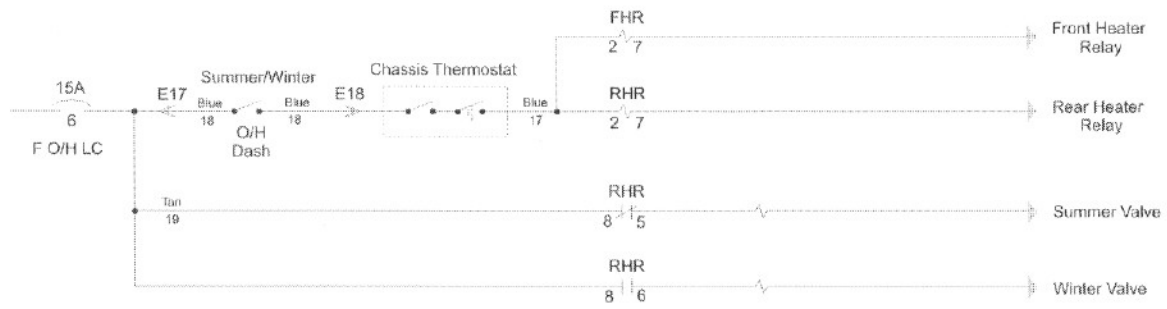
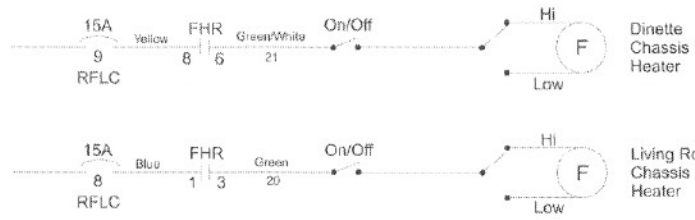

F O/H LC - Front Overhead Load Center
 RFLC - Right Front Load Center
 MLC - Lower Front Load Center

Reference	Description
BBC	L. Scott W. Schreurs
DESIGN	DRAWN CHECKED

Chassis Heat
 (Page 1 of 3)

BLUEBIRD WANDERLODGE CO.
 FORT VALLEY GEORGIA U.S.A.
 1984 F.C.35 SB

Date	Revision	Description
Nov. 8, 2007	1	Removed Front Heat Diagram

DWG NO 1984-008 Rev 1

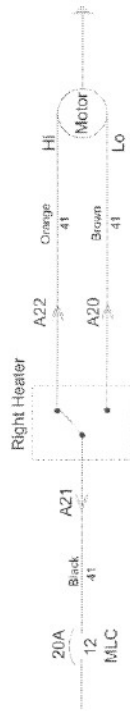
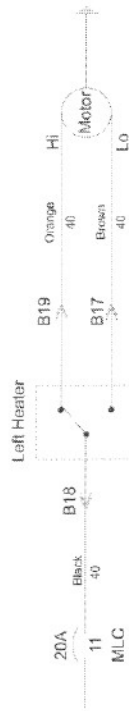
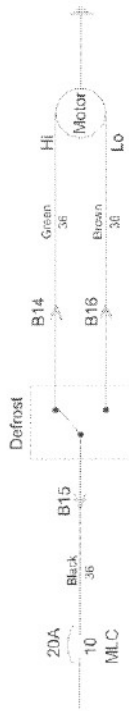

MLC - Lower Front Load Center

Front Heat

Reference	Description
BBC	L. Scott W. Schreurs
DESIGN	DRAWN CHECKED

Dash Heater System

BLUEBIRD WANDERLODGE CO.
FORT VALLEY, OREGON, U.S.A.
1984 F.C. 36, SB

DWG NO 1984 - 009 Rev 1

Date	Revision	Description
Nov. 7, 2007	1	Added Dash Heater Solenoid



Lower Front
Load Center

Reference	Description
BBC	L. Scoll W. Schreurs
DESIGN	DRAWN
	CHECKED
Compartment Lights	
BLUEBIRD WANDERLIDGE CO. FORT VALLEY, GEORGIA U.S.A. 1984 F.C. 35 SB	
DWS NO 1984-010	

Date	Revision	Description



Front Overhead
Load Center

Reference	Description
BBC	L. SCOTT W. SCHREIBS
DESIGN	DRAWN
	CHECKED

Marker Lights

BLUEBIRD WANDERLodge CO.
FORT VALLEY, GEORGIA, U.S.A.
1984 F.C. 35 SB



DWG NO 1984-011

Date	Revision	Description

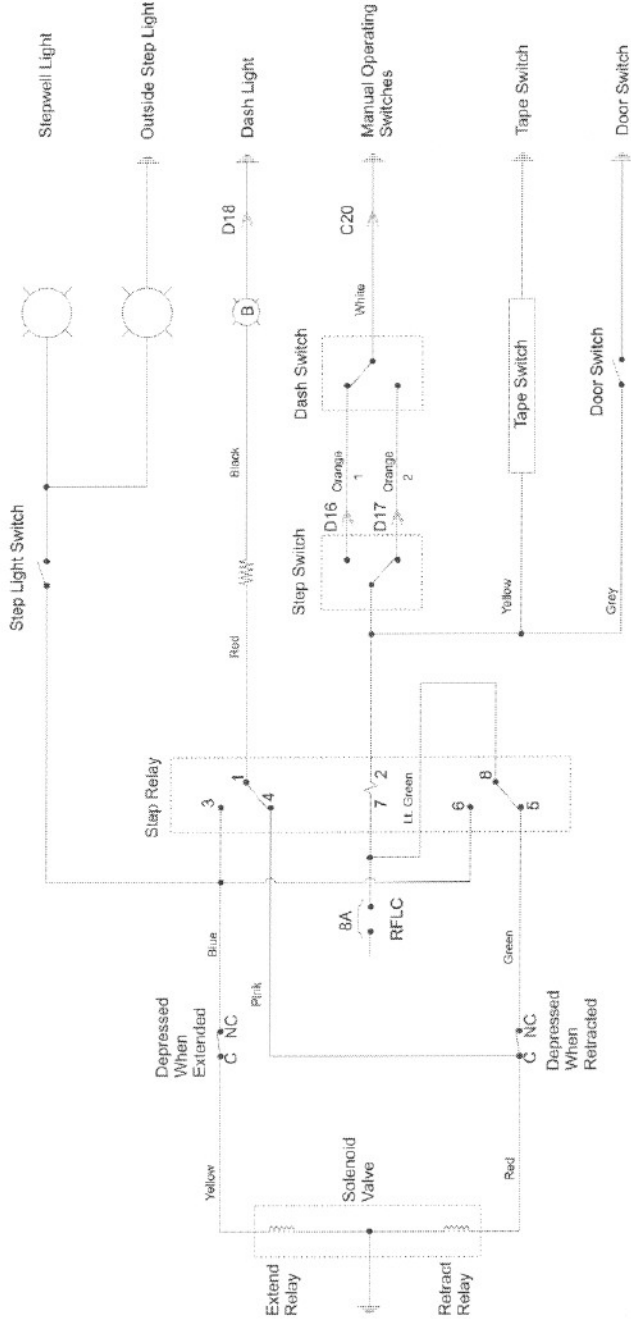

RFLC - Right Front Load Center

Reference	Description
BBC	L. Scott
DESIGN	W. Schreurs
	DRAWN
	CHECKED

Door Step - Electrical
(Page 1 of 2)

Date	Revision	Description

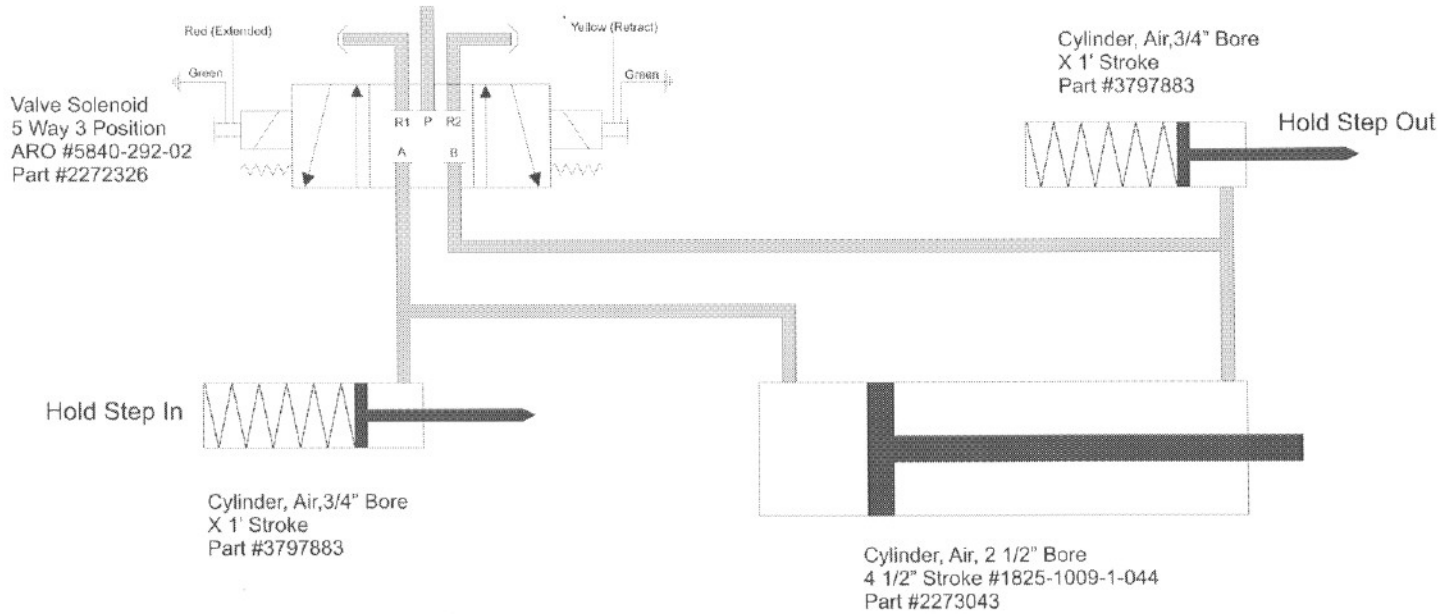

Reference	Description	
BBC	L. Scott	W. Schreurs
DESIGN	DRAWN	CHECKED
Door Step - Mechanical (Page 2 of 2)		
BLUEBIRD WANDERLODGE CO. FORT VALLEY GEORGIA U.S.A. 1984 F.C. 35 SB		
DWG NO	1984-012A Rev 1	

Date	Revision	Description
Nov 10, 2007	1	Added "Hold Step In", Cylinder Modification & Modified to Pneumatic Schematic

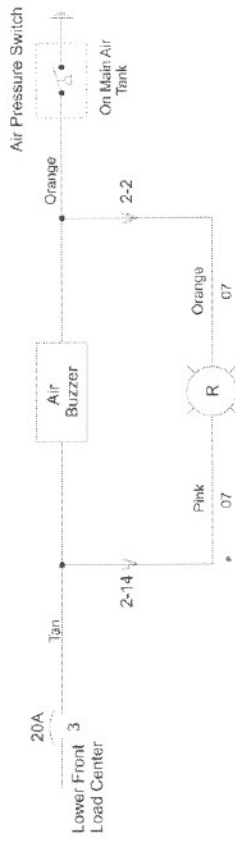

Reference	Description
BBC	L. Scott W. Schraus
DESIGN	DRAWN
	CHECKED
Air Buzzer	
BLUEBIRD WANDERLOGGE CO. FORT VALLEY GEORGIA U.S.A. 1984 F.C.35 SB	
DWS NO 1984-013 Rev 1	

Date	Revision	Description
Nov. 8, 2007	1	Added location of Air Pressure Switch

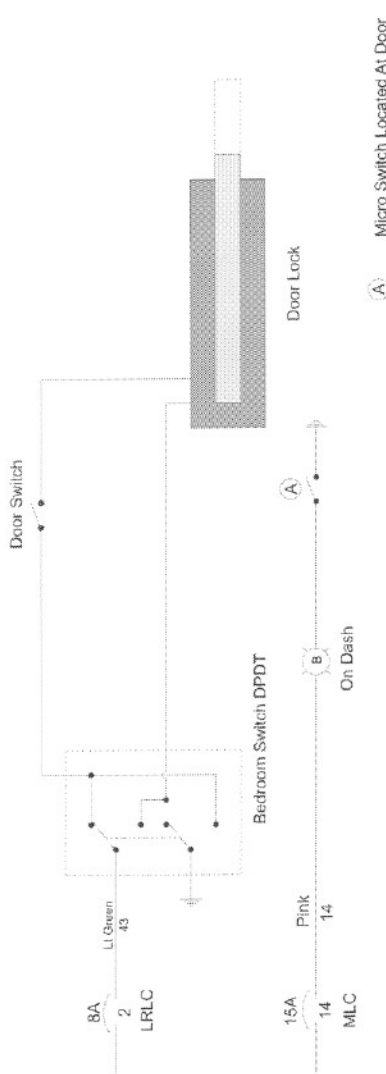

(A) Micro Switch Located At Door
 LRLC - Left Rear Load Center
 MLC - Lower Front Load Center

Reference	Description
BBC	L. Scott W. Scheitels
DESIGN	DRAWN
	CHECKED

Door Lock	
BLUEBIRD WANDERLodge CO FORT VALLEY, OREGON 97131 1984 F.C. 35, SB	
DWG NO	1984-014

Date	Revision	Description

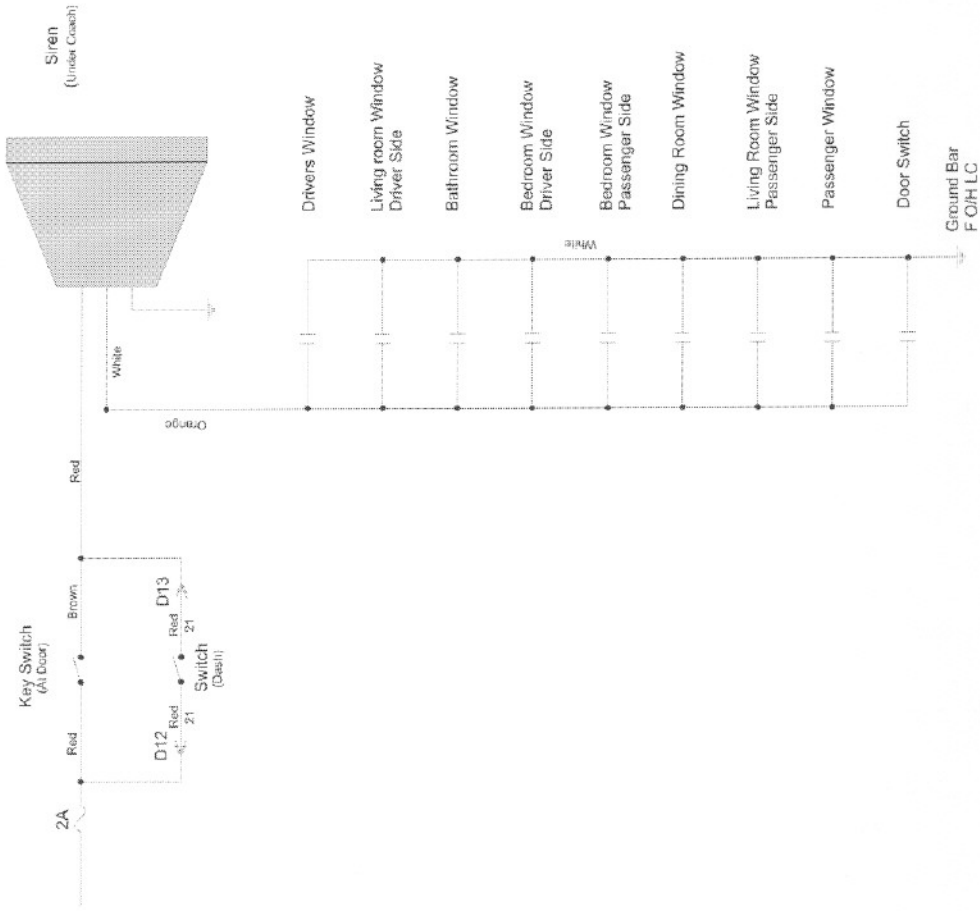

Reference	Description
BBC	L. Scott W. Schreurs
DESIGN	DRAWN
	CHECKED

Date	Revision	Description

Burglar Alarm

BLJEBIRD WANDERLODGE CO
 FERT VALLEY, OREGON, U.S.A.
 1984 F.C. 96, 98



DWG NO 1984-016



Reference	Description
BBC	L. Scott W. Schreurs
DESIGN	DRAWN
	CHECKED

Max Fuel Flow	
BLUEBIRD WANDERLOGGE CO. FORT VALLEY GEORGIA U.S.A. 1984 F.C. 35 SB	
DWG NO 1984-018	

Date	Revision	Description

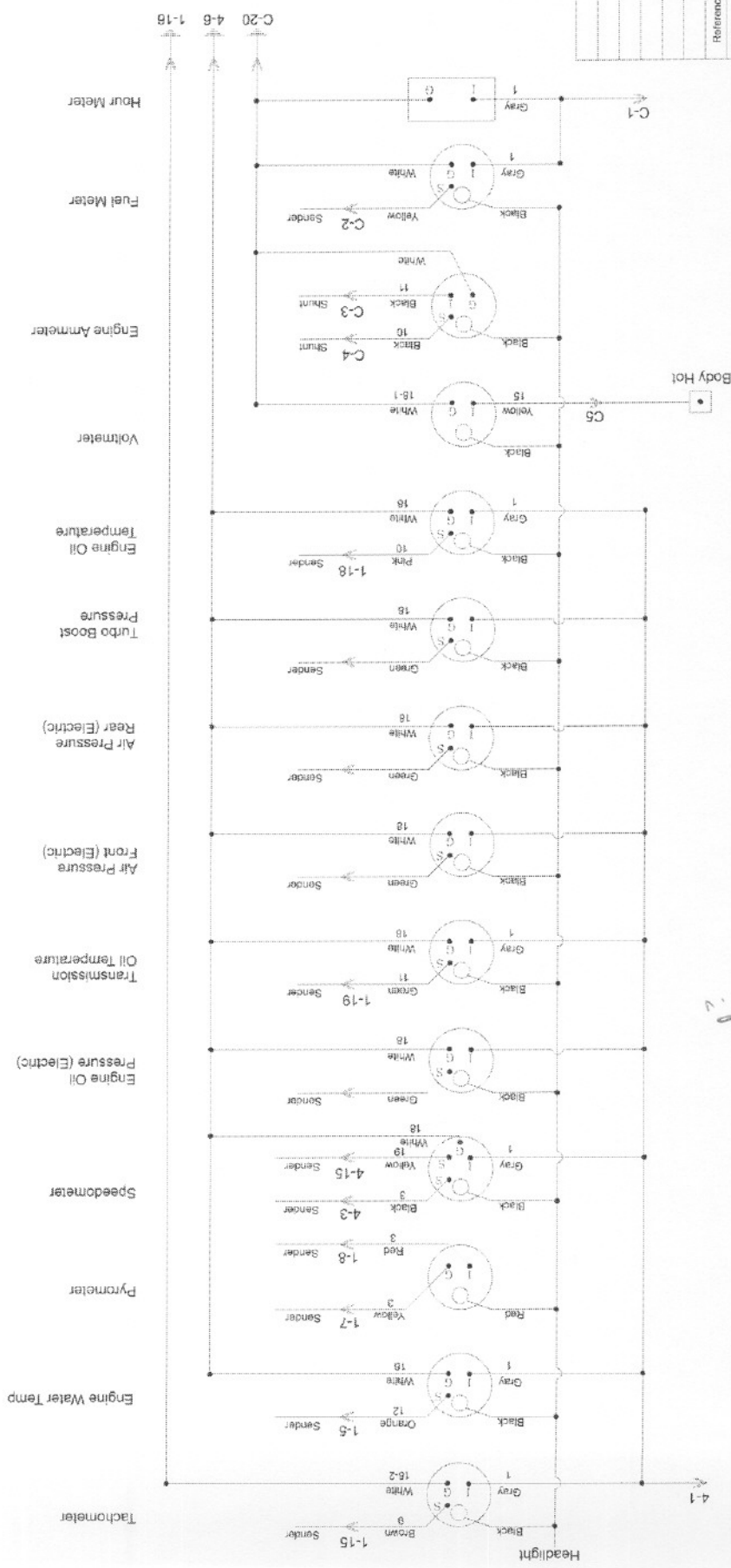

Oil Press. no mechanical

Reference	BBC	Description	W. Schreurs
DESIGN	L. Scott	DRAWN	CHECKED

Gauges

BLUEBIRD WANDERLodge CO.
FORT WALLY, GEORGIA U.S.A.
1984 F.C. 85 SB

DWG NO 1984-019

Date	Revision	Description

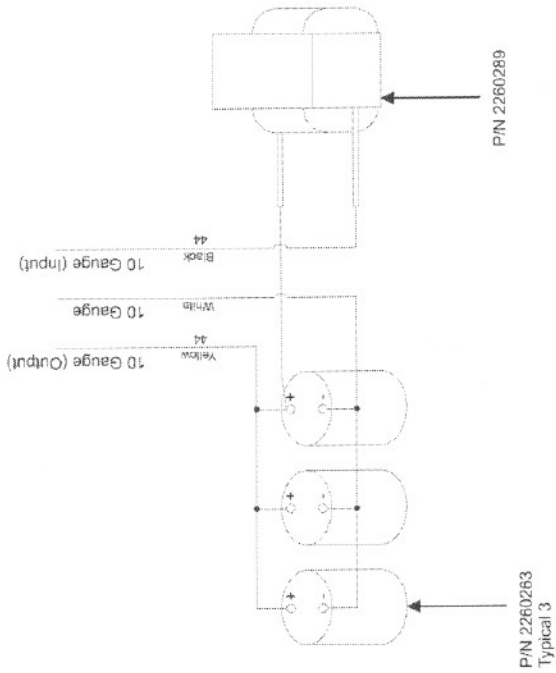

Reference	Description
BBC	L. Scott W. Scheuers
DESIGN	DRAWN
	CHECKED

12 Volt Filter System
(Page 1 of 2)
BB Dwg 3922812

BLUEBIRD WANDERLodge CO.
FORT VALLEY, GEORGIA U.S.A.
1984 F.C. 35 SB

DWG NO 1984-020

Date	Revision	Description

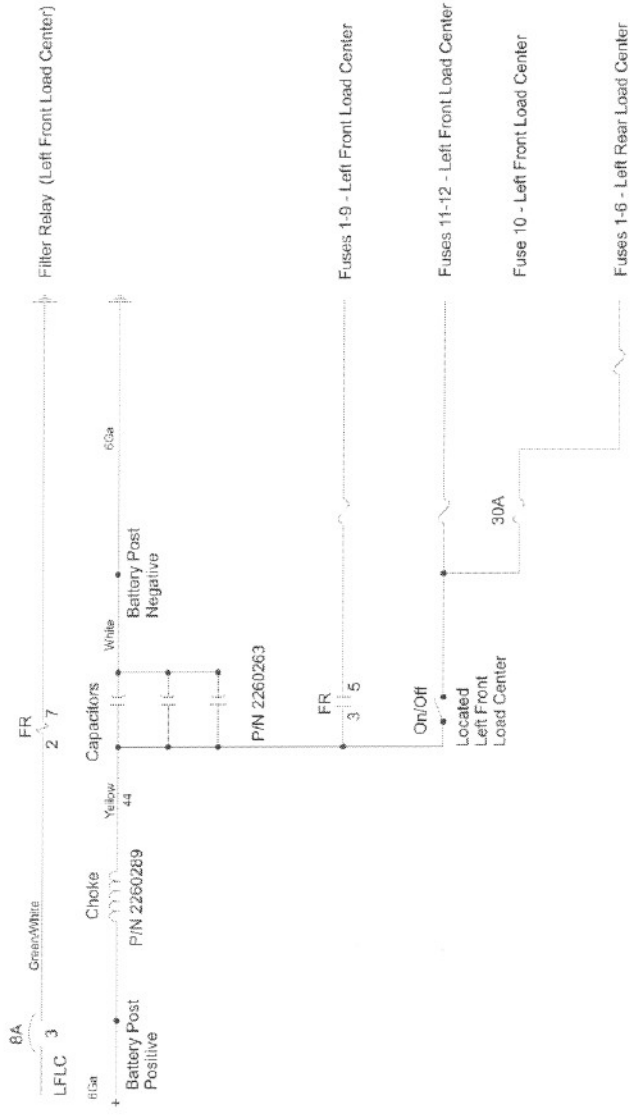

Reference	Description
BEC	L. Scott W. Schreurs
DESIGN	DRAWN CHECKED

12 Volt Filter System
(Page 2 of 2)

BLUEBIRD WANDERLodge CO.
FORT VALLEY, GEORGIA U.S.A.
1984 F.C. 35 SB



DWG NO 1984-020A

Date	Revision	Description

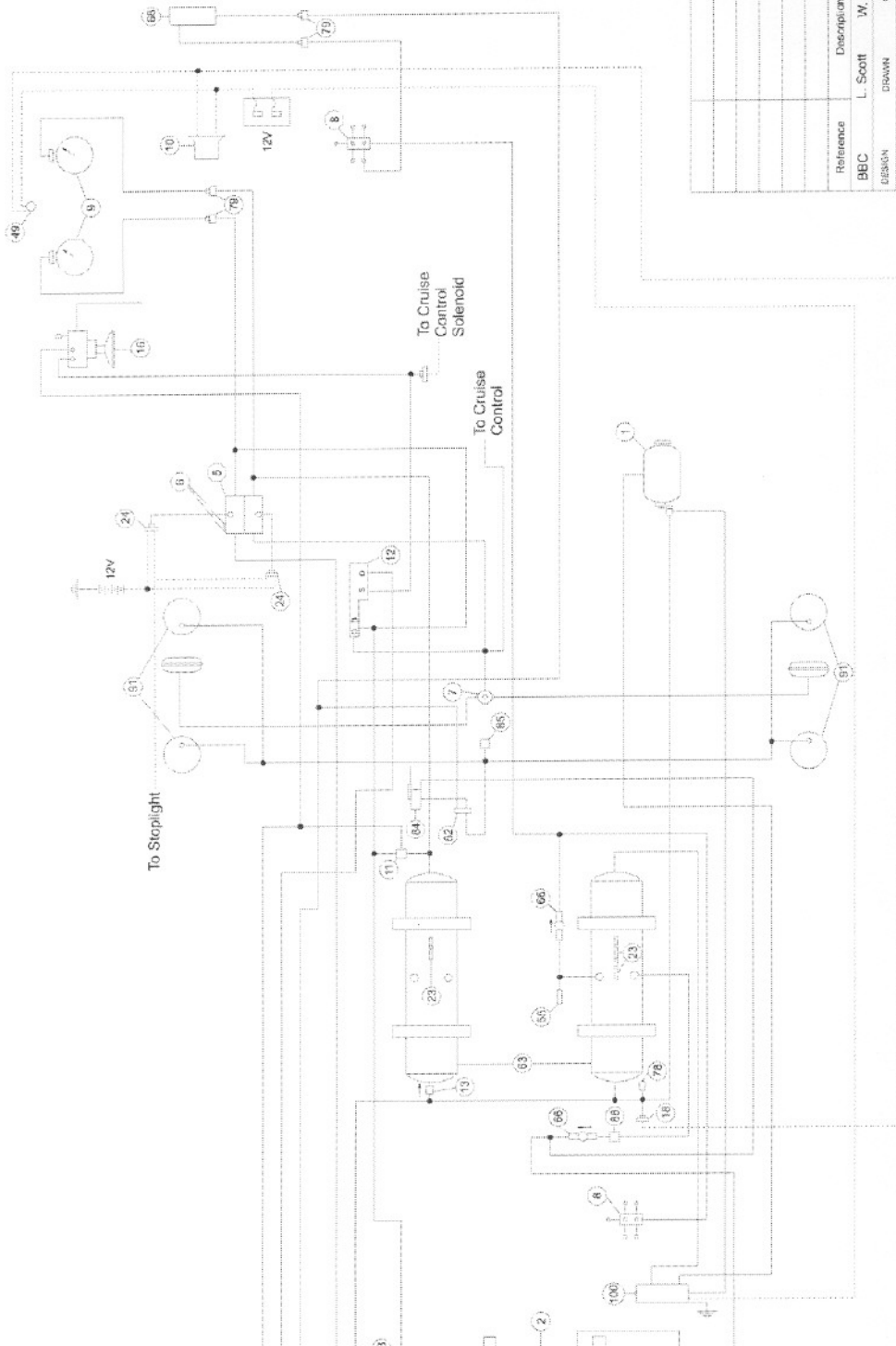

Reference	Description
BEC	L. Scott
DESIGN	W. Schreurs
DRAWN	
CHECKED	

Compressed Air System
(Page 1 of 2)

BLUEBIRD WANDERLOGGE CO.
FORT VALLEY, GEORGIA U.S.A.
1984 F.C. 35 SB

DWG NO 1984-021A

Date	Revision	Description

Item #	BB Part #	Vendor Part #	Description
	1		Air Compressor
2	0754929	B-W 227629	Reservoir, 8" X 26" / 1240 Cu in.
5	0654533	B-W 286171	Valve, Dual Brake, E6
6	0654525	B-W 226834	Treadle, Dual Brake Valve
7	2023075	B-W 229813	Valve, Quick Release 3/8 Pipe Supply
8	2023083	B-W 212322	Manifold Fitting (Junction Block)
9	0981779	Teleflex 9181278	Gauge, Air Pressure
10	2006187	Essex 44310-0	Buzzer, 12 volt
11	0654434	B-W 278614	Valve, Double Check, 3/8 pipe
12	0654426	B-W 286364	Valve, Spring Brake
13	0654418	B-W 227871	Valve, Single Check, 1/2 pipe
15	0654400	B-W 286370	Valve, Relay, R-8
16	0900266	B-W 289954	Valve, PP-1 Control 206.9Kpa / 30PSI
17	0818708	B-W 287224	Valve, Relay, R-8
18	0654384	B-W 283949	Indicator, Low Pressure, 1/4 pipe
23	2023117	B-W 278351	Drain Cock, 1/4 pipe
24	0998740	W-M 777A 118150	Switch, Stop Light, 1/4 pipe Williams 777A 118150
49	2006807	Cole Hersee PL-19	Light, Pilot, 13.5/ 17/32 Red lens
55	083909	B-W 284142	Safety Valve, 1/4" Male pipe
62	0982280	WM 147-P	Valve, Relay, Pilot Control
63	0991513	Johnson D1229	Reservoir, 9 1/2" X 27" / 1760 Cu in.
66	0522508	Midland N-15759-C	Valve, Pressure Protection 448.2Kpa/65PSI
68	2227338	Cross TV-3 S	Valve, Air, TV-3 S
78	0818609	Shrader 1498A6	Valve, Schrader, 1/4"NPT
79	0949370	Gould 129-B	Adapter, Bulkhead 1/8 pipe x 1 1/2 in long
80	0949388	Gould 298-PD-04 X 2	Coupling, Quick Disconnect
84	0871376	Ridewell S-2736B	Height Control Valve
85	0982918	B-W 276599	Indicator, Low Pressure LP-3, 30PSI
88	0962183	Ridewell S-688B	Filter, Air, Ridewell Suspension
90	0961250	Ridewell S-2061C	Air Spring, Ridewell Front Suspension
91	0961425	Ridewell S-3082C	Air Spring, Ridewell Front Suspension
100	0801373	B-W 286931	Air Dryer

1984-036	Front Seats
1984-035	Tilt Steering
1984-034	Air Vents
1984-033	Generator Slide
1984-032	Black Water Dump Valve
1984-031	Grey Water Dump Valve
1984-012	Door Stop Mechanical
1984-004	Air/Electric Horns
1984-002	Bulk Oil Tank System

Reference	Description
BBC	L. Scott W. Schreurs
DESIGN	DRAWN CHECKED

**Compressed Air
System
(Page 2 of 2)**

BLUEBIRD WANDERLODGE CO.
FORT VALLEY, GEORGIA U.S.A.
1984 F.C. 35 SB 

Nov. 8, 2007	1	Added Additional Reference Drawing Info
Date	Revision	Description

DWG NO 1984-021 Rev. 1

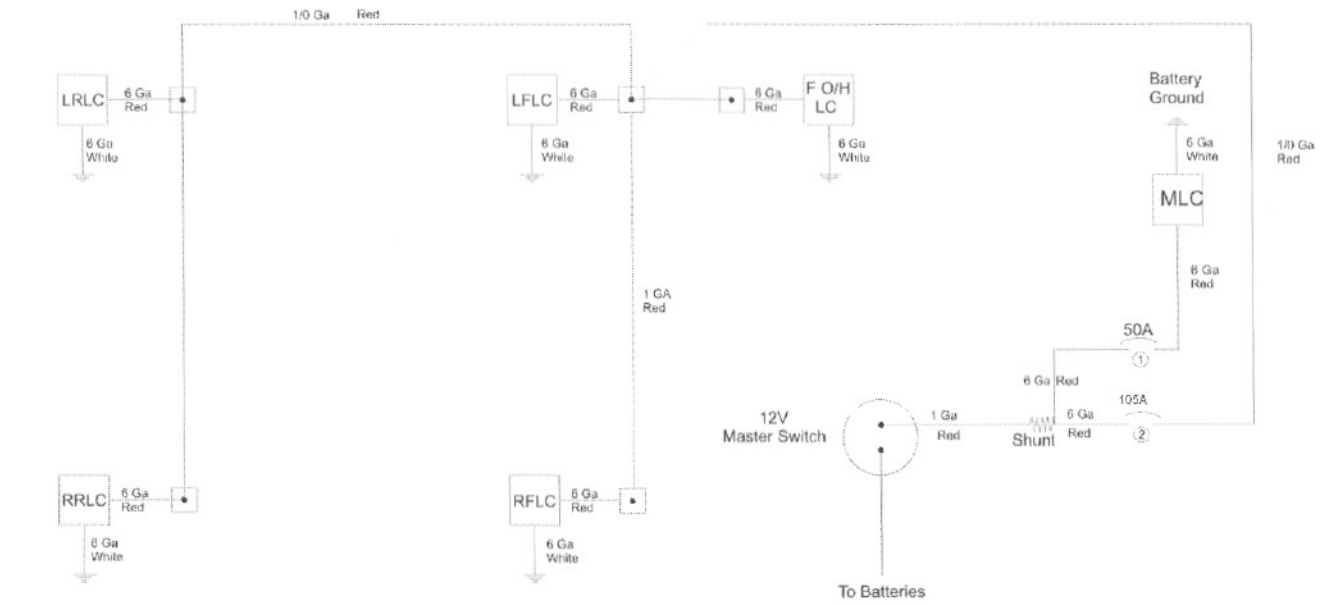

- ① 3768041 50 Amp
- ② 3768058 105 Amp
- 3745288 Terminal Block
- Grounded To Copper Bus Unless Otherwise Specified

- MLC - Lower Front Load Center (2 of 7)
- F O/H LC - Front Overhead Load Center (3 of 7)
- LFLC - Left Front Load Center (4 of 7)
- RFLC - Right Front Load Center (5 of 7)
- LRLC - Left Rear Load Center (6 of 7)
- RRLC - Right Rear Load Center (7 of 7)

Reference	Description
BBC	L. Scott W. Schreurs
DESIGN	DRAWN CHECKED
Main Wire Harness & Load Centers (Page 1 of 7)	
BLUEBIRD WANDERLODGE CO. FORT VALLEY GEORGIA U.S.A. 1984 F.C.35 SB	
DWG NO 1984-022	

Date	Revision	Description

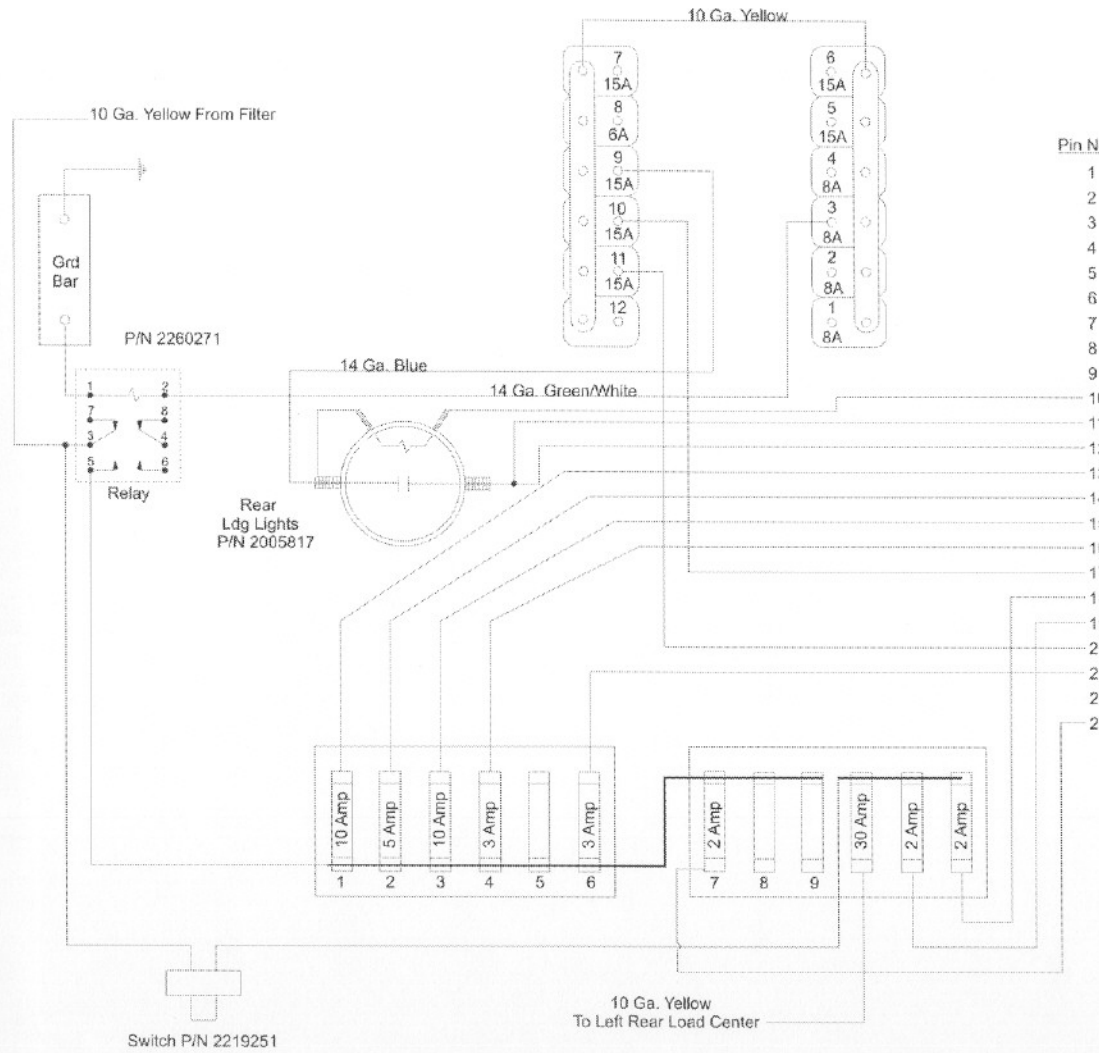

Pin No.	Circuit Bkr
1	16 Ga. #20 Dark Blue - Living room Reading Lts. LH Side
2	16 Ga. #15 Red/Black - 12V Outlet in Bath & Stove Lt.
3	16 Ga. #18 Green/Black - Bath Reading & Shower Lt.
4	14 Ga. #23 Brown/Orange - Living Room Vent Fan
5	16 Ga. #25 Lt Green - Bath & Kitchen Vent Fan
6	14 Ga. #28 Yellow - Bath & Kitchen Floor Lts.
7	14 Ga. #10 Yellow/Black Kitchen LP Furnace
8	14 Ga. #12 Red - Living Room LP Furnace
9	14 Ga. #16 Purple - To Duct Booster
10	16 Ga. #23 Grey - To Rear Landing Lt. Switch on Dash
11	14 Ga. #24 Green/White - To Rear Landing Lt.
12	14 Ga. #24 Green/White - To Rear Landing Lt.
13	14 Ga. #2 Orange/Brown - Remote TV
14	14 Ga. #3 Green/White - 12V Am/FM Radio
15	16 Ga. # 4 Brown/Orange - Musical Horn Boosters & Electronics
16	18 Ga. #5 Red - CB Radio
17	
18	10 14 Ga. #65 Yellow/Black - Stereo 12V DC
19	18 Ga. #6 Black - Clock on Dash
20	16 Ga. #35 Pink - Memory for AM/FM Radio
21	14 Ga. #38 Black - Rear Amp Stereo
22	14 Ga. #72 Orange/Black - Stereo Front Amp
23	8 18 Ga. #4 Red - Water Pump Lt. In Bathroom
	14 Ga. #4 Black - Intercom

Reference	Description	
BBC	L. Scott	W. Schreurs
DESIGN	DRAWN	CHECKED
Left Front Load Center (Page 4 of 7)		
BLUEBIRD WANDERLODGE CO. FORT VALLEY, GEORGIA, U.S.A. 1984 F.C.35 SB		
DWG NO	1984-022C	

Date	Revision	Description

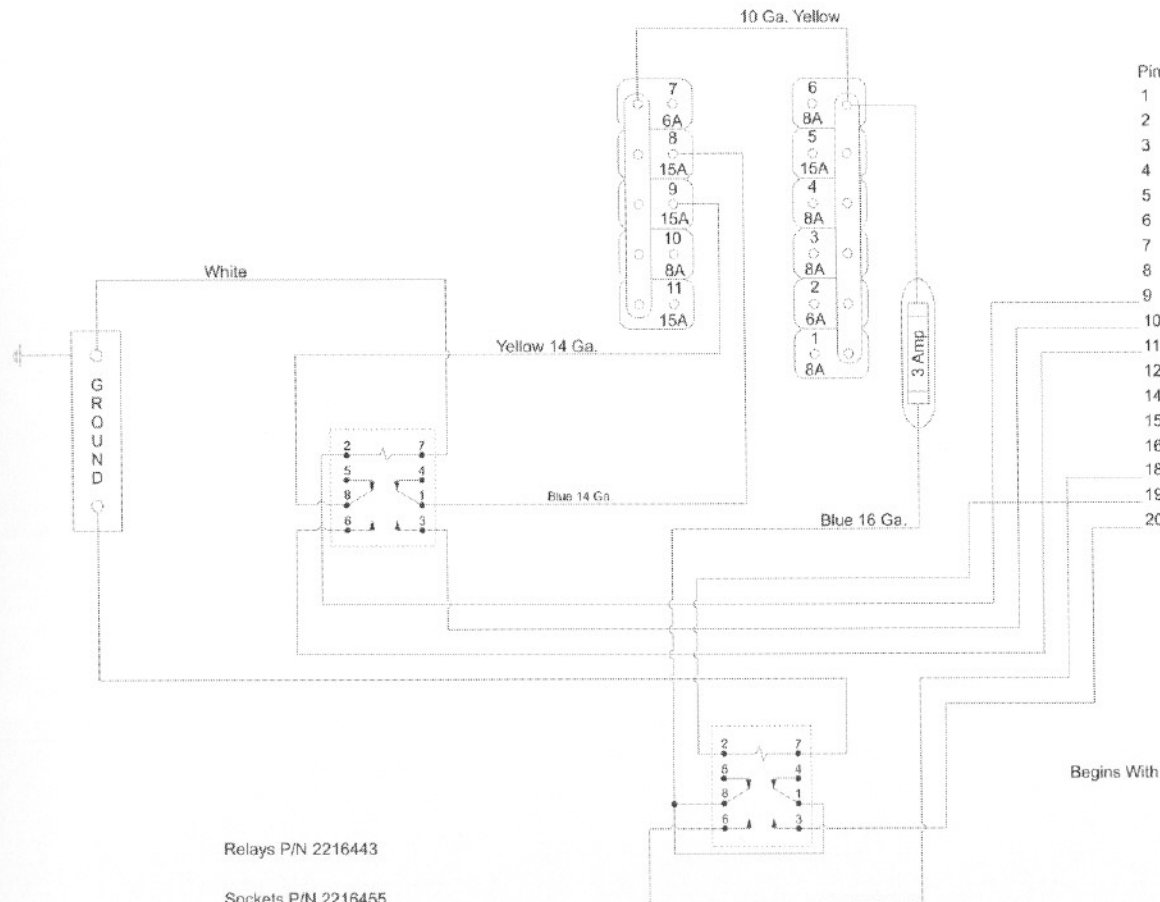

Pin No.	Clr Bkr	Description
1	1	16 Ga. #6 Lt Green - To Pin #7 On Step Relay
2	1	16 Ga. #9 Grey/White - Porch Light & Change Over Compt. Switch Light
3	2	16 Ga. #11 Brown/Orange - Dining Room Reading Lights
4	2	18 Ga. #15 Black - Half Closet Light Switch
5	3	16 Ga. #13 Red/Black - 12V Outlet @ Half Closet
6	4	14 Ga. #23 Dark Blue - LR Reading Lights RS
7	5	14 Ga. #25 Yellow - LR Fluo Light Switch
8	6	16 Ga. #26 Brown/Orange - Entrance & Dining Room Fluo Light Switch
9		18 Ga. #18 Lt. Blue - Chassis Heat Thermostat Wire (2 Wires to RRLC)
10		14 Ga. #20 Green - LR Chassis Heater Switch
11		14 Ga. #21 Green/White - Dinette Chassis Heater Switch
12	6	16 Ga. #41 Pink - Generator In-Out Switch In Change Compts.
14	10	16 Ga. #12 Red/Black - 12VDC Recept. Front
15	11	14 Ga. #1 Red - Antenna Motor (up & down)
16	7	14 Ga. #9 Red - Antenna Booster & TV Rotor
18		16 Ga. #71 Red/Black - Stereo
19		16 Ga. #70 Orange - Stereo
20		14 Ga. #68 Black/Yellow - Stereo, Rear Amp

Relays P/N 2216443
Sockets P/N 2216455

Begins With Body No.60727

Reference	Description
BBC	L. Scott W. Schreurs
DESIGN	DRAWN CHECKED
Right Front Load Center (Page 5 of 7)	
BLUEBIRD WANDERLODGE CO. FORT VALLEY GEORGIA U.S.A. 1984 F.C.35 SB	
DWG NO	1984-022D

Date	Revision	Description

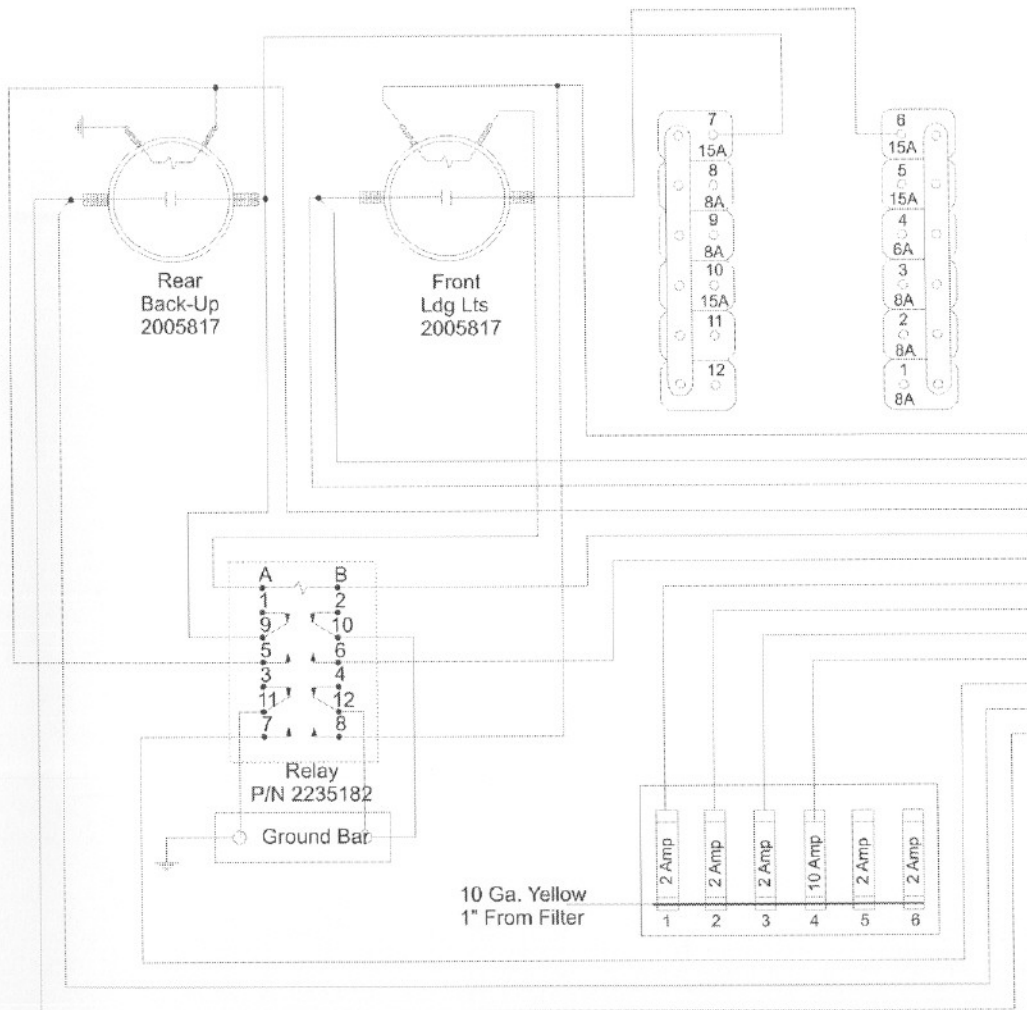

Pin No. CCT Bkr

- | | | |
|----|----|--|
| 1 | 1 | 14 Ga. #20 Dark Blue - B/R Reading Lts. Lh |
| 2 | 2 | 16 Ga. #43 Green - Electric Dr Lock Power |
| 3 | 3 | 16 Ga. #14 Grey - Closet & Ref. Switch |
| 4 | 4 | 16 Ga. #16 Orange/Brown - Fresh Water Tank Fill |
| 5 | 4 | 18 Ga. #17 Black Water Blowout Switch |
| 6 | 4 | 16 Ga. #18 White/Green - Ref. Vent Fan |
| 7 | 5 | 14 Ga. #8 Red - LP Furnace In B/R |
| 8 | | 16 Ga. #21 Pink - Front Landing Lts. Sol. To Dash Switch |
| 18 | | 14 Ga. #25 Blue/Black - To Front Landing Lts. |
| 19 | | 14 Ga. #25 Blue/Black - To Front Landing Lts. |
| 9 | | 16 Ga. #20 Green/Black - Back-Up Security Lts. To Dash |
| 12 | | 18 Ga. #4 Orange - To B/R Security Lt. Switch |
| 10 | | 16 Ga. #23 Grey - To Rear Landing Lts. Sol (Front Load Center) |
| 24 | | 18 Ga. #23 Black - Door Chime |
| 23 | | 18 Ga. #38 Red - Alarm Clock Rear Bedroom |
| 14 | | 16 Ga. #30 Red/Black - Monitor Panel In Kit. |
| 15 | | 14 Ga. #31 Purple - Marshall Brass |
| 11 | | 16 Ga. #22 Red/Black - To Solenoid At Toe Board (Driving Lts.) |
| 20 | | 14 Ga. #26 White/Black - To Back-Up Security Lts. |
| 21 | | 14 Ga. #26 White/Black - To Back-Up Security Lts. |
| 22 | 9 | 16 Ga. #10 Brown - To Aisle Lt Switch |
| 16 | 10 | 14 Ga. #38 Black - Bedroom Stereo Amp Blaupunkt |

Reference	Description	
BBC	L. Scott	W. Schreurs
DESIGN	DRAWN	CHECKED

Left Rear
Load Center
(Page 6 of 7)

BLUEBIRD WANDERLODGE CO.
FORT VALLEY GEORGIA, U.S.A.
1984 F.C. 35 SB

DWG NO 1984-022E

Date	Revision	Description

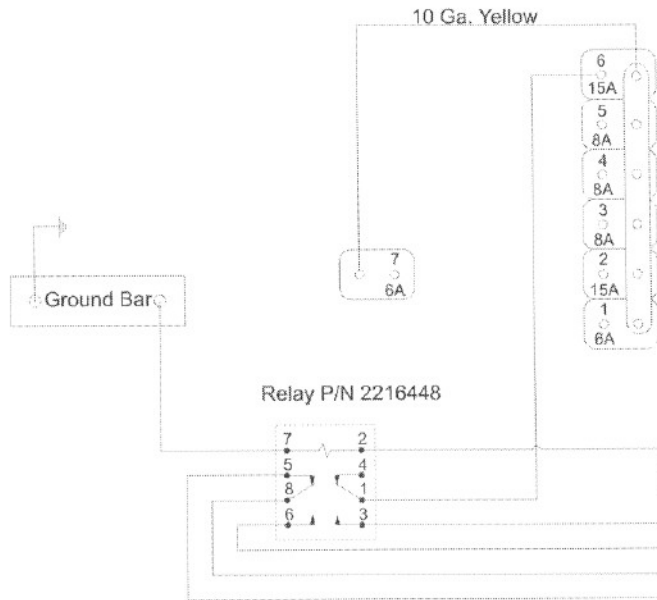

Pin No CCT Bkr

- 1 1 16 Ga. #25 White/Green - Kitchen Fluor. L
- 2 2 14 Ga. #27 Yellow - Bedroom Fluor Lts / I
- 3 3 16 Ga. #1 Black - RH Closet Lt Switch
- 4 4 14 Ga. #1 Dark Blue - Bedroom Reading
- 5 5 16 Ga. #13 Red/Black - Bedroom 12V Out
- 7 16 Ga. #18 Lt. Blue - Right Front Ld. Ctr.
- 6 14 Ga. #22 Dark Green - Bedroom Chas:
- 9 16 Ga. #23 Red/Black - Winter Solenoid
- 8 16 Ga. #19 Tan - Ign. Wire For Summer/A
- 10 18 Ga. #24 Black - Summer Solenoid Val
- 12 16 Ga. #18 Orange - AC Switch Relay
- 13 14 Ga. #2 Grey - Camera Defog

hours
CKED

Date	Revision	Description



Reference	Description
BBC	L. Scott W. Schreurs
DESIGN	DRAWN
	CHECKED
Lighter	
BLUEBIRD WANDERLodge CO.	
FORT VALLEY, BERKSHIRE CO. MA.	
1984 F.C. 95.5B	
DWG NO	1984-023

Date	Revision	Description

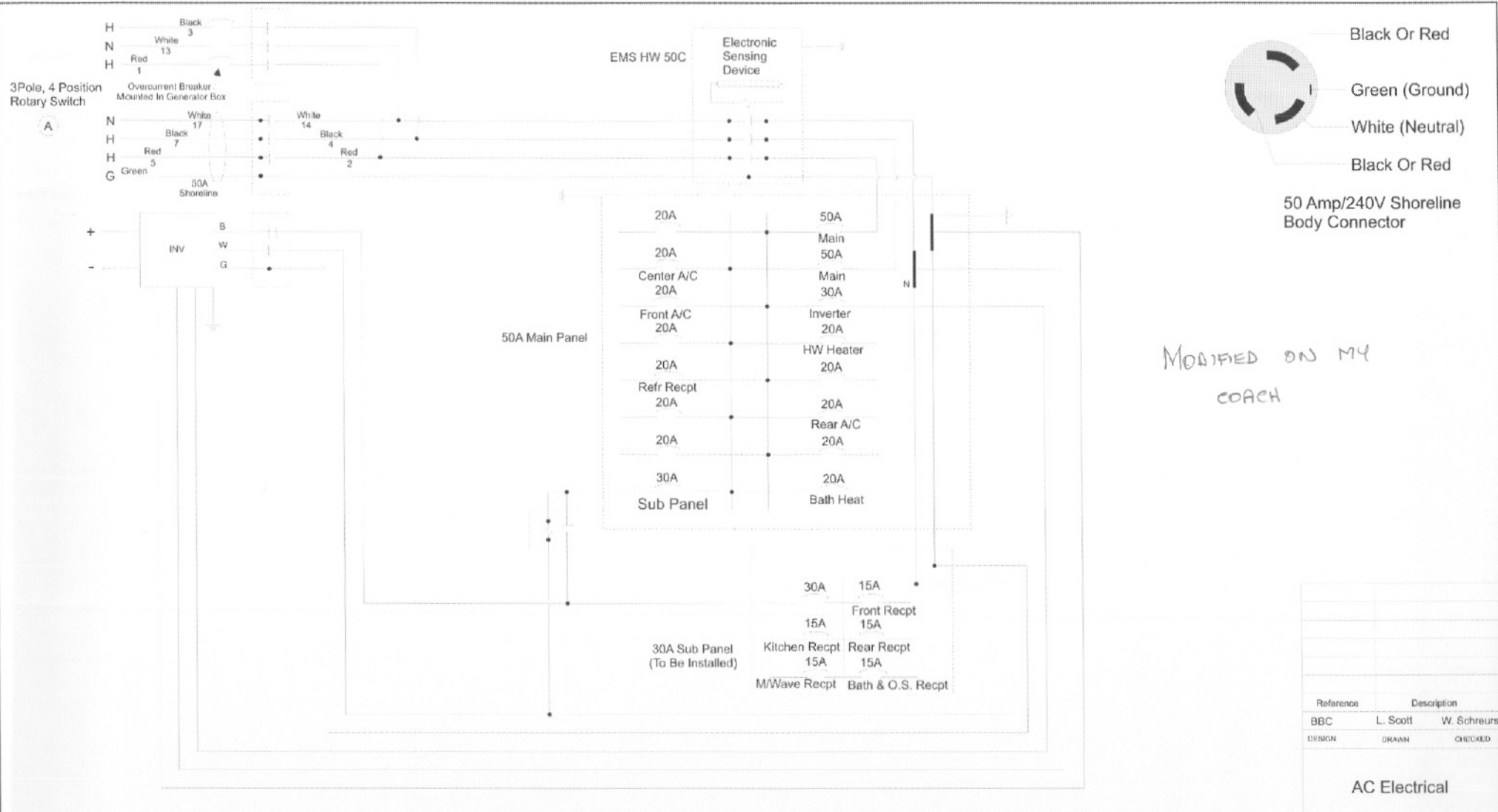

MODIFIED ON MY
COACH

A
Kraus & Naimer C-105 B2B1-E
UL Listed 100 Amps

Note - Neutral Is NOT
To Be Bonded To Ground

Date	Revision	Description
Aug 1, 2008	2	Revised Inverter output through transfer switch
May 18, 2008	1	Revised Inverter Input and Output

Reference	Description	
BBC	L. Scott	W. Schreurs
DESIGN	DRAWN	CHECKED

AC Electrical

BLUEBIRD WANDERLODGE CO.
FORT VALLEY GEORGIA U.S.A.
1984 F.C. 35 SB

DWG NO 1984-024

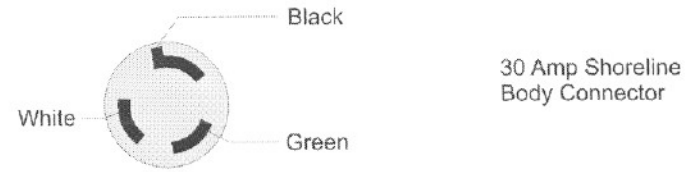
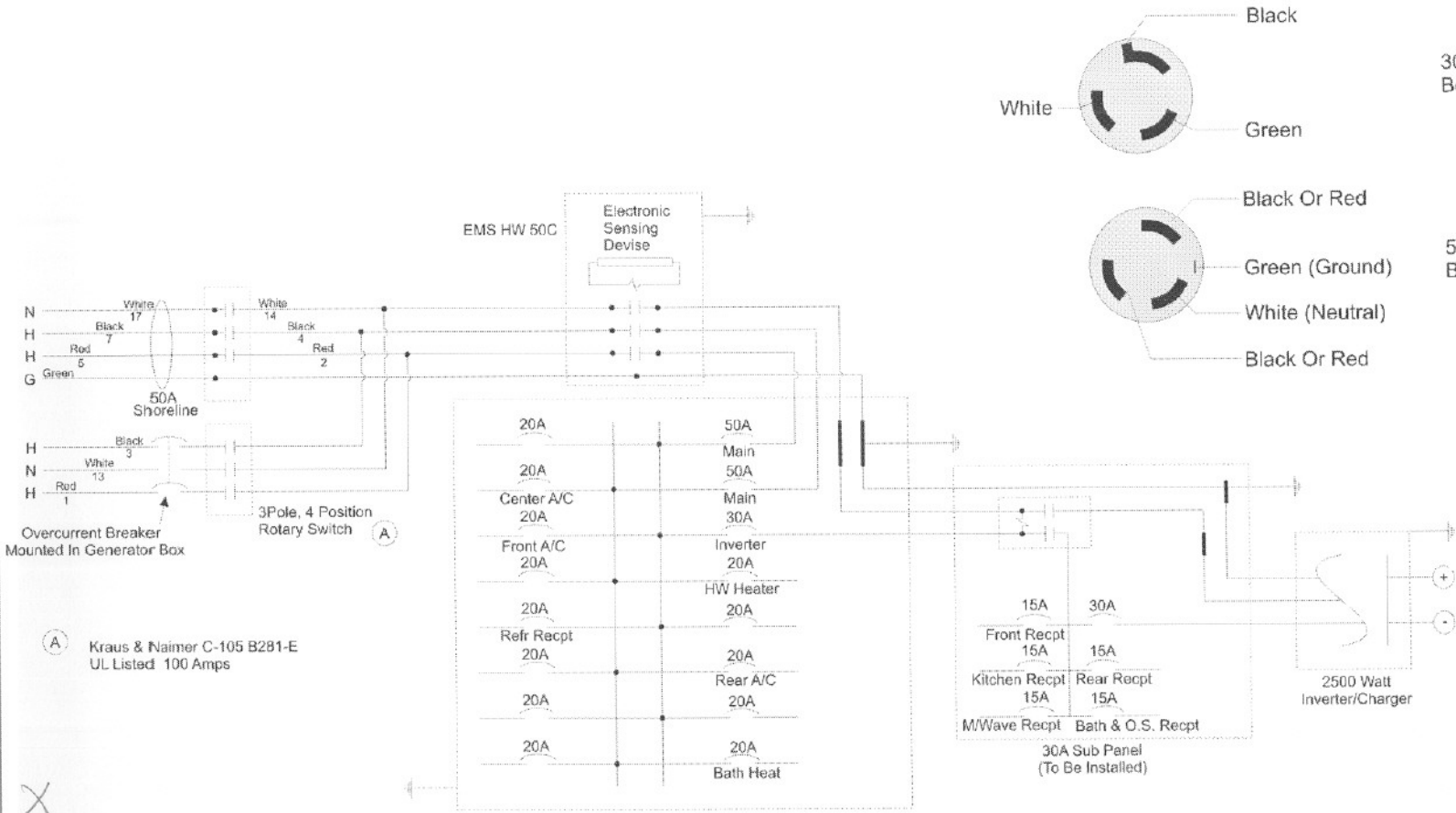

(A) Kraus & Naimer C-105 B2B1-E
UL Listed 100 Amps

X

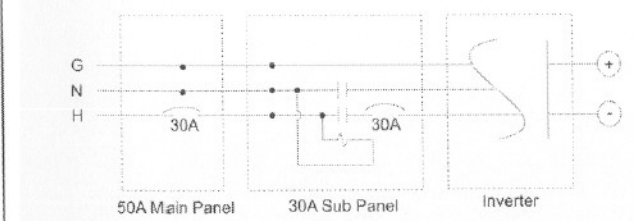

Note - Neutral Is NOT To Be Bonded To Ground

Reference	Description	
BBC	L. Scott	W. Schreurs
DESIGN	DRAWN	CHECKED
AC Electrical		
BLUEBIRD WANDERLODGE CO. FORT VALLEY GEORGIA U.S.A. 1984 F.C.35 SB		
DWG NO	1984-024	

Date	Revision	Description



Lower Front Load Center



Lower Front Load Center

Reference	Description
BBC	L. Scott W. Schreurs
DESIGN	DRAWN
	CHECKED

Wiper Heater and Pump

BLUEBIRD WANDERLodge CO.
FORT VALLEY, GEORGIA, U.S.A.
1984 F.C. 35 SB

DWG NO 1984-025

Date	Revision	Description

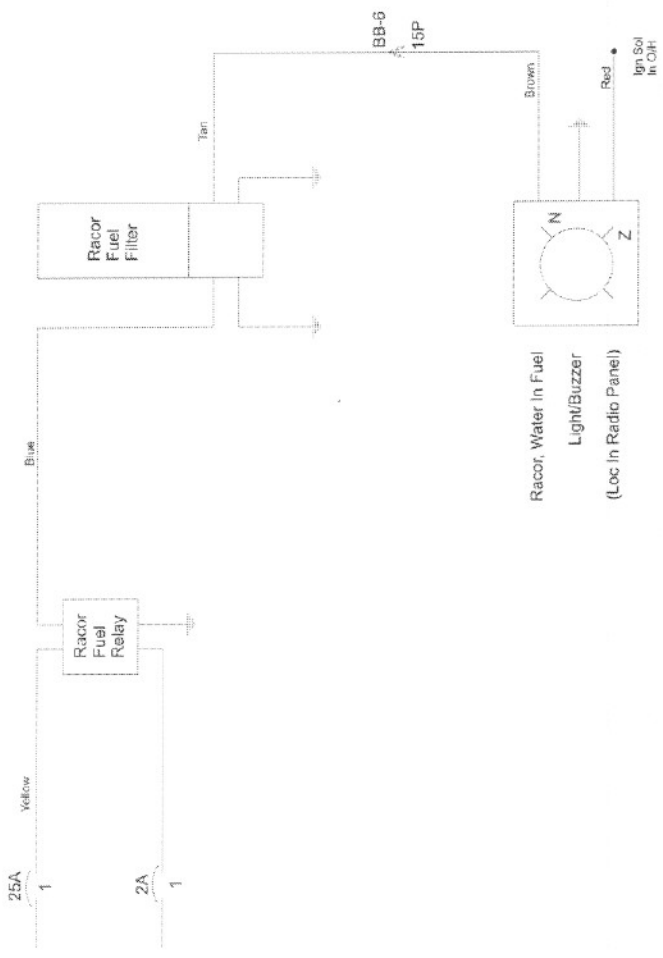

Reference	Description
BBC	L. Scott
DESIGN	W. Schneurs
	DRAWN
	CHECKED

Racor Fuel Filter

BLUEBIRD WANDERLODISE CO
 FORT VALLEY GEORGIA U.S.A.
 1984 F.C.35.SB

DWG NO 1984-026

Date	Revision	Description

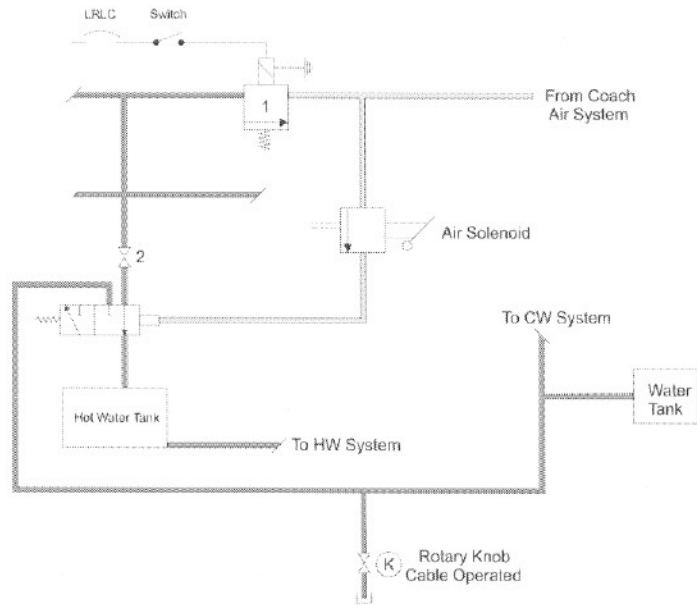

NORMAL OPERATION:

- K Rotary knob - cable operated drain valve closed
- Air Switch in "Off" position
- 2 Valve Open
- Sporlan Valve switch open, 1 valve in normally closed position

DRAIN WATER and HOT WATER TANKS:

- Operate Air Switch
- K Rotary knob - cable operated drain valve - turn to open

PRESSURIZE SYSTEM FOR DRAINING (from NORMAL OPERATION)

- Close Sporlan Valve Air Operated Switch
- Open then close taps throughout coach
- Open outside valve in Bulk Oil Storage area

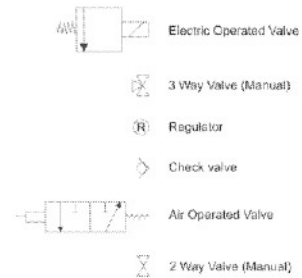

Reference	Description	
BBC	L. Scott	W. Schreurs
DEBZN	DRAWN	CHECKED

Fresh Water Piping System (Page 2 of 5)

BLUEBIRD WANDERLODGE CO.
FORT VALLEY GEORGIA U.S.A.
1984 F.C.35 SB

DWG NO 1984-027A Rev1

Date	Revision	Description
Nov 11, 2007	1	Changed symbols of valving

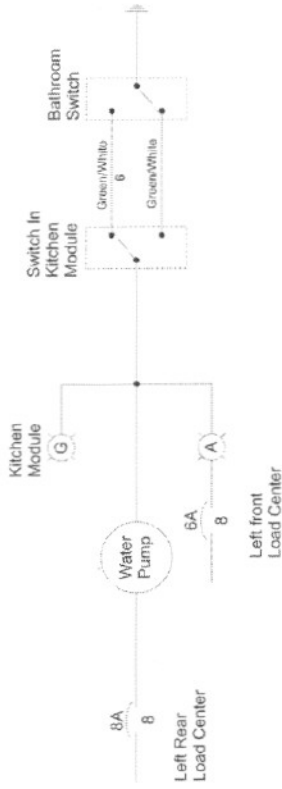

Reference	Description
BEC	L. Scott W. Schreitz
DESIGN	DRAWN
	CHECKED

**Fresh Water,
Water Pump
(Page 3 of 5)**

BLUEBIRD WANDERLODGE CO.
FORT VALLEY, GEORGIA U.S.A.
1984 F.C. 35 SB

DWG NO 1984-027B

Date	Revision	Description

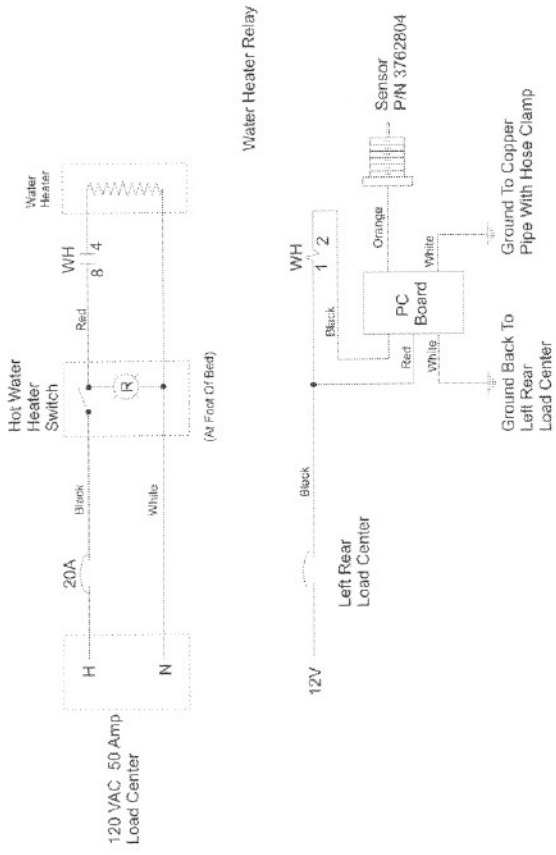

Reference	Description
BBC	L. Scott W. Schreurs
DESIGN	DIANN
	CHECKED

Fresh Water
Hot Water Tank/Dry Sw
(Page 4 of 5)

BLUEBIRD WANDERLodge CO.
FORT VALLEY GEORGIA U.S.A.
1984 F.C.35 SB

DWG NO 1984-027C

Date	Revision	Description

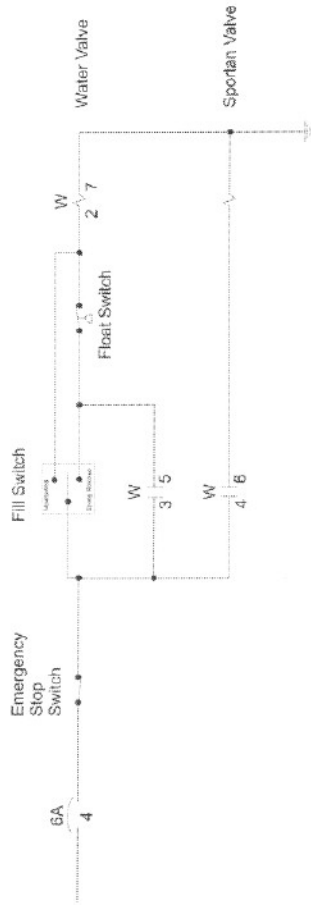

Water Tank Overfill

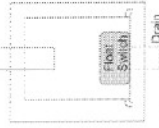

Container Within Container With Float Switch

TO BE INSTALLED

Reference	Description
BBC	L. Scott W. Scheufls
DESIGN	DRAWN
	CHECKED
Fresh Water Auto Fill & Stop (Page 5 of 5)	
BLUEBIRD WANDERLODGE CO. FORT VALLEY, GEORGIA U.S.A. 1984 F.C. 36 SB	
DWG NO	1984-027D

Date	Revision	Description

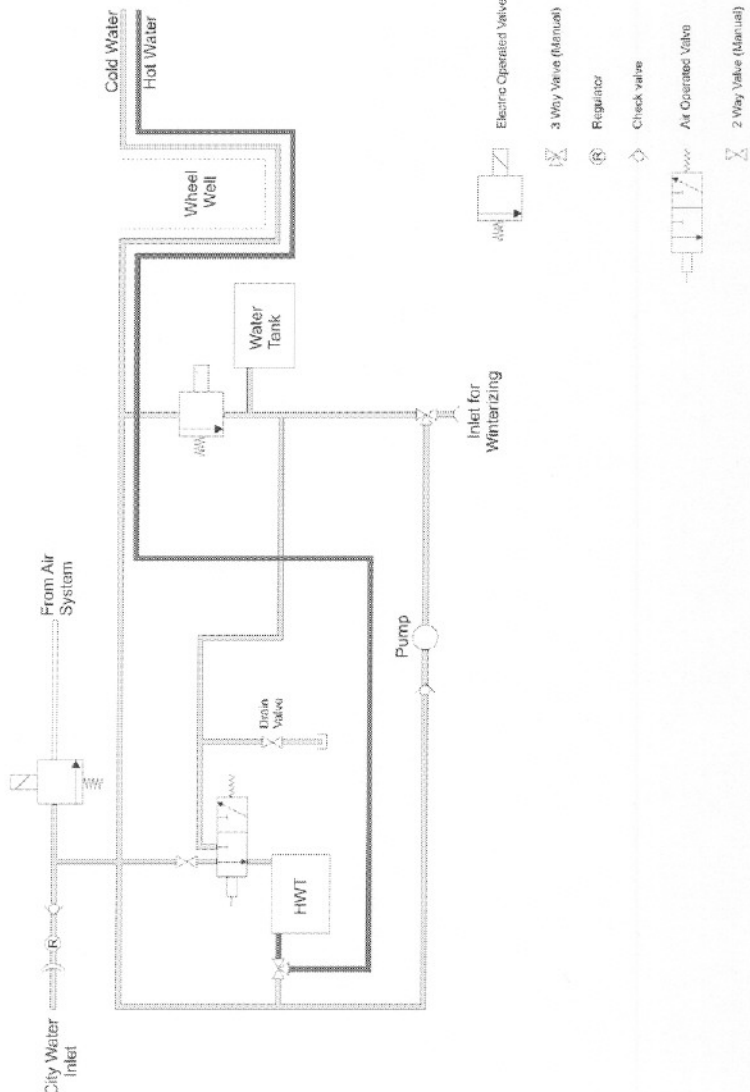

Reference	Description
BBC	L. Scott W. Schreurs
DESIGN	DRAWN CHECKED

Fresh Water
Piping System
(Page 1 of 5)

BLUEBIRD WANDERLODGE CO.
PO BOX 100
PORT WASHINGTON
1984 FC-955B

DWG NO 1984-027 Rev1

Date	Revision	Updated Symbols	Description
Nov. 11, 2007	1		

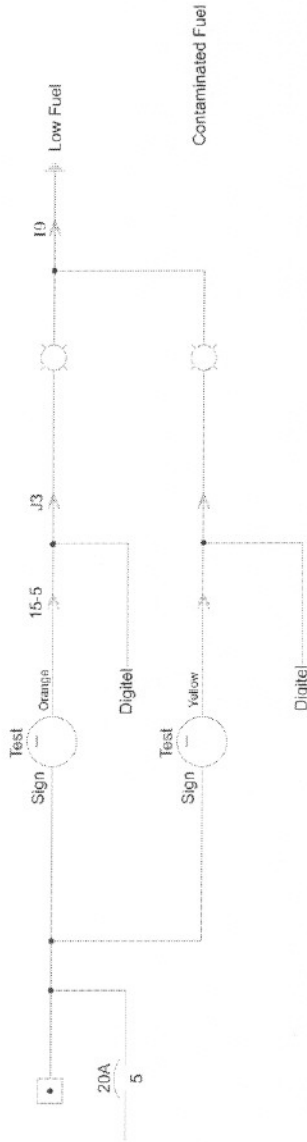

Reference	Description
BBC	L. Scott
DESIGN	W. Schreurs
	DRAWN
	CHECKED
Low Fuel Contaminated Fuel	
BLUEBIRD WANDERLODGE CO. FORT VALLEY, INDIANA, USA 1984 F.C. 35, SB	
DWG NO	1984-028

Date	Revision	Description

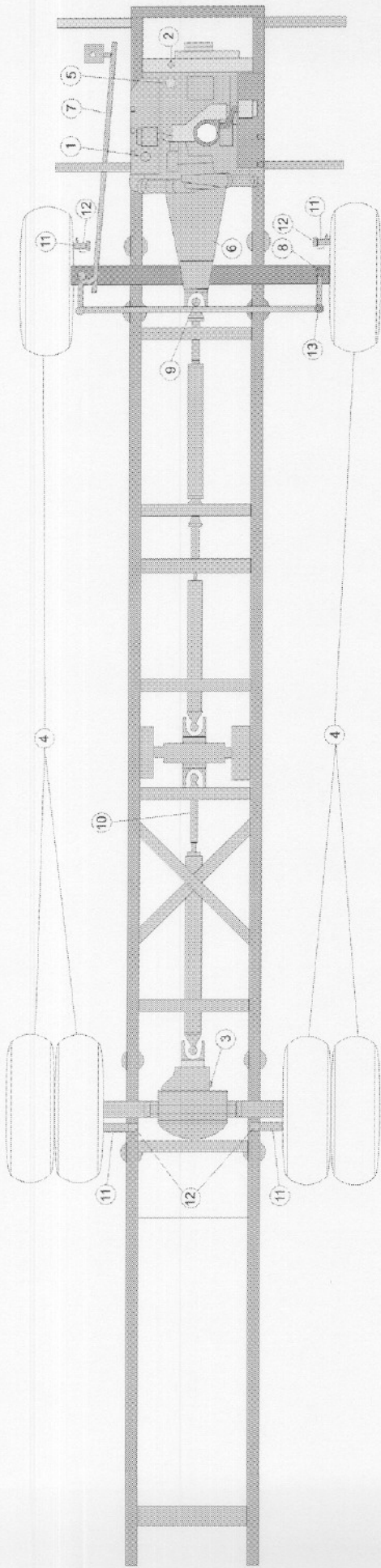

Key	Service Period	Check	Description	General Instruction	Recommended Lubricant	Key	Service Period	Check	Description	General Instruction	Recommended Lubricant
1	See Owners Manual	Daily	Engine Oil	Check Level	Follow Engine Manufacturer's recommendation	8	Once at 4,000 miles		Front Axle	4 Fittings -- No periodic Maintenance Required	NLG1 Grade #2
2	See Owners Manual		Engine Oil Filter		Follow Engine Manufacturer's recommendation	9	* 15,000 miles or 3 months		Propeller Shaft Universal Joint	1 Fitting each joint use low pressure	NLG1 Grade #2
3	* 25,000 miles or 6 months	1,000 miles	Rear Axle	Keep oil to level of filler plug, drain and refill at first 1,000 to 1,500 miles, and then at recommended intervals. Check level testing plug in side of carrier housing	Hypoid Gear Oil SAE 140 or SAE 85/140 or SAE 85W/90	10	* 15,000 miles or 3 months		Propeller Shaft Slip Joint	1 Fitting -- Use low pressure	NLG1 Grade #2
4	Once a Year	1,000 miles	Wheel bearings front axle	Change lubricant whenever seals are replaced or when brakes are refilled or at least once a year	80,140	11	* 15,000 miles or 6 months		Brake Camshaft	4 Fittings	NLG1 Grade #2
5	Not Required	5,000 miles	Hydraulic Power Steering Pump	No Periodic Maintenance Required	SAE 85W/90	12	* 15,000 miles or 6 months		Brakeslike Adjuster	4 Fittings	NLG1 Grade #1 (Special SlopMaster Grease)
6	See General Instructions	Monthly	Automatic Transmission (Allison)	EXTERNAL FILTER - first 5,000 miles, then every 25,000 miles or 6 months INTERNAL FILTER - first oil change, then at 500,000 miles or overhaul OIL - 100,000 miles or 12 months	Dexton II	13			Tie Rod Ends	Permanently Lubricated	
7	* 5,000 miles or 6 months		Steering Linkage (Drag Rod)	5 Fittings	NLG1 Grade 2						

Lubrication Guide Chassis

Reference
BBC
L. Scott
W. Schreurs

Description
DESIGN
DRAWN
CHECKED

BLUEBIRD WANDERLodge CO.
FORT VALLEY, OHIO, U.S.A.
1984 F.C. 95 SB

DWG NO 1984-029

Data Revision Description

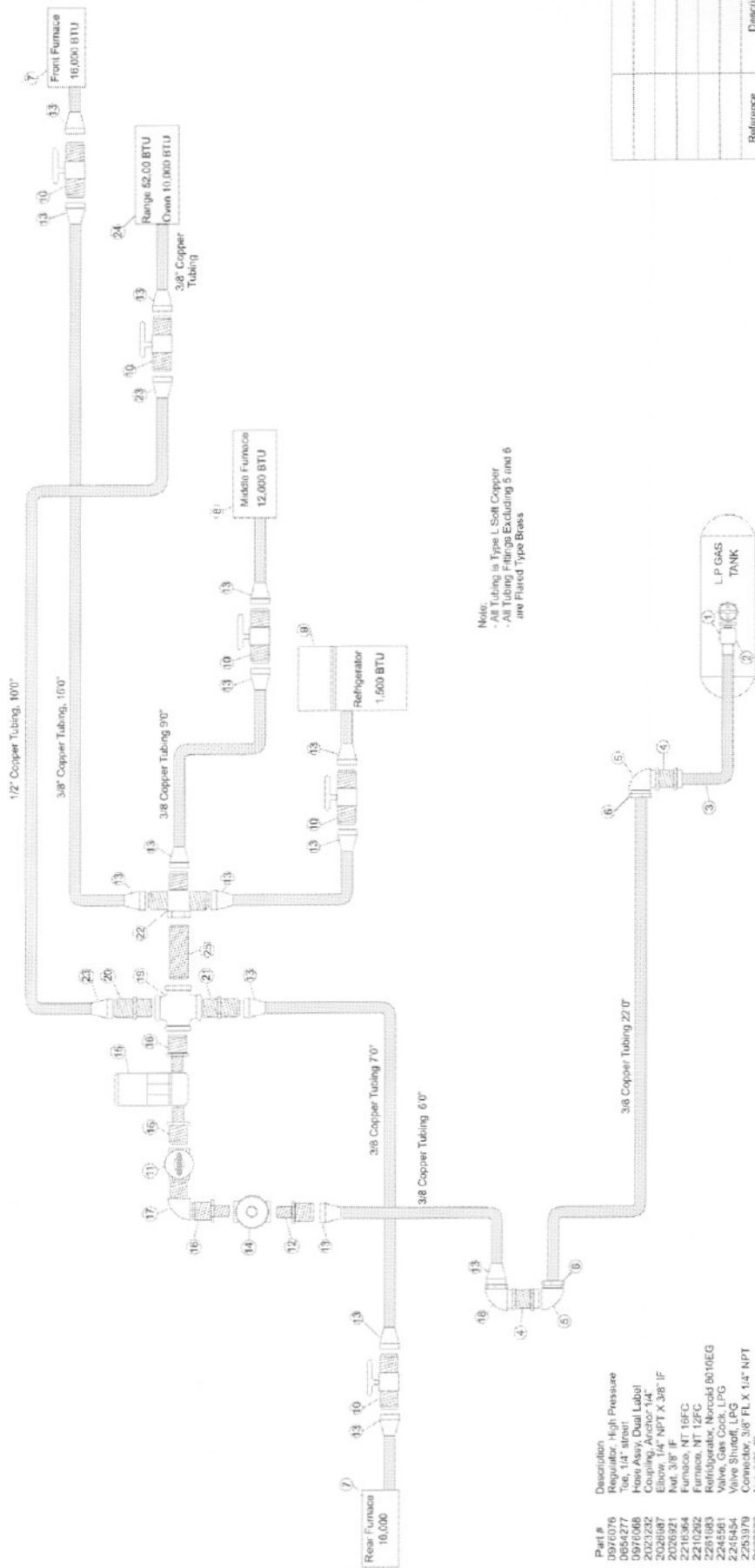

Note:
 -All Tubing is Type L Soft Copper
 -All Tubing Fittings Excluding 5 and 6
 are Flared Type Brass

Item	Part #	Description
1	0976076	Regulator, High Pressure
2	0654277	"one, 1/4" street
3	0976068	Iron Assy, Dual Label
4	2020182	Coupling, Reducer
5	2020182	Elbow, 1/4" NPT X 3/8" IF
6	2020321	Nut, 3/8" IF
7	2216364	Furnace, NT 18FC
8	2210262	Furnace, NT 12FC
9	2251983	Refrigerator, Norcold B010EG
10	2245591	Valve, Gas Cook, LPG
11	2255454	Valve Shutoff, LPG
12	2020179	Gas Valve, 3/8" FL X 1/4" NPT
13	2020176	Regulator, Low Pressure
14	2266307	Leak Detector Shut Off Valve
15	2256315	Apple, Hex, 3/8" NPT X 1/2" NPT
16	2222735	Steel Elbow, 1/2" Pipe
17	2222727	Elbow, 1/4" NPT X 3/8" FL
18	2260719	Cross, 1/2" FPT, FL X 1/2" NPT
19	2257005	Connector, 3/8" FL X 1/2" NPT
20	2257007	Flange, 1/2" FPT X 3/8" FL
21	0377374	Nut, 1/2" FL
22	2027084	Range, "Chateau" Stainless, 12V - 747
23	0633505	Apple, 1/2" Close
24	2196459	
25		

Reference	Description
BBC	L. Scott W. Schreurs
DESIGN	DRAWN
	CHECKED

LP GAS SYSTEM PIPING DIAGRAM

BLUEBIRD WANDERLodge CO.
 FORT VALLEY GEORGIA U.S.A.
 1984 F.C. 35 SB

DWG NO 1984 - 030

Date	Revision	Description

OWDS  Grey Water Dump Solenoid

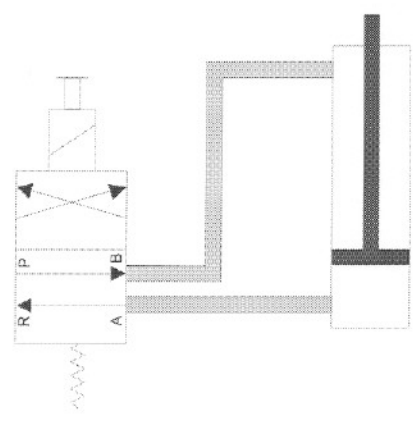

Under Handle Remove 2 Screws
Pull the Stem and Valve Out
and Clean as Required

1984-021	Compressed Air System
Reference	Description
BBC	L. Scott W. Schreurs
DESIGN	DRAWN
	CHECKED
Grey Water Dump	
BLUEBIRD WANDERLodge CO.	
PORT WASHINGTON, WASH.	
1984 F.C. 35.5B	
DWG NO	1984-031

Date	Revision	Description

BWDS  Black Water Dump Solenoid

Under Handle Remove 2 Screws
 Pull the Stem and Valve Out
 and Clean as Required

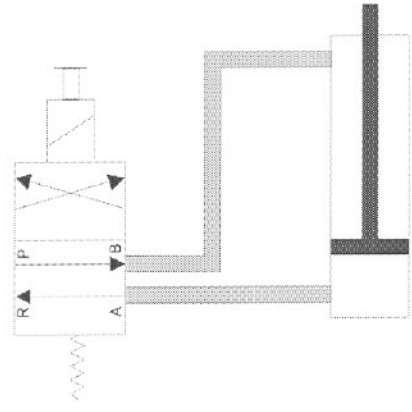

1984-021	Compressed Air System
Reference	Description
BBC	L. Scott W. Schreurs
DESIGN	DRAWN
	CHECKED

**Black Water
Dump**

BLUESIRD WANDERLodge CO.
 PORT WALKER, WISCONSIN, U.S.A.
 1984 F.C. 36, SB



DWG NO 1984-032

Date	Revision	Description



Valve Solenoid
5 Way 3 Position
ARO #5840-292-02
Part #2272326

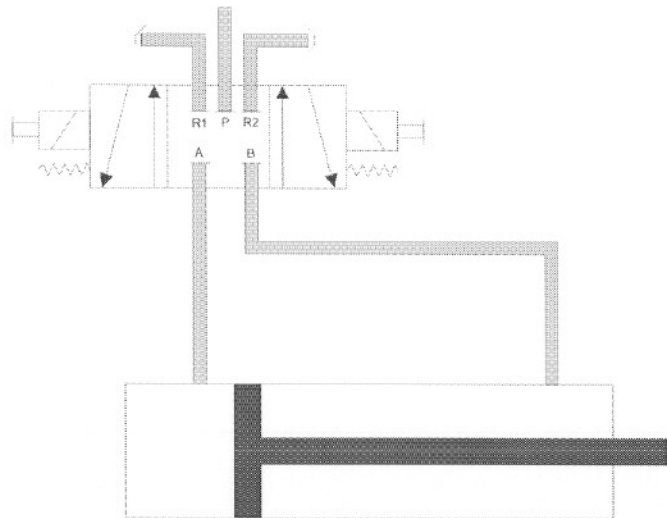

1984-021	Compressed Air System
Reference	Description
BBC	L. Scott W. Schreurs
DESIGN	DRAWN CHECKED
Generator Slide	
BLUEBIRD WANDERLODGE CO. PORT VALLEY GEORGIA U.S.A. 1984 F.C. 35 SE	
DWG NO	1984-033

Date	Revision	Description

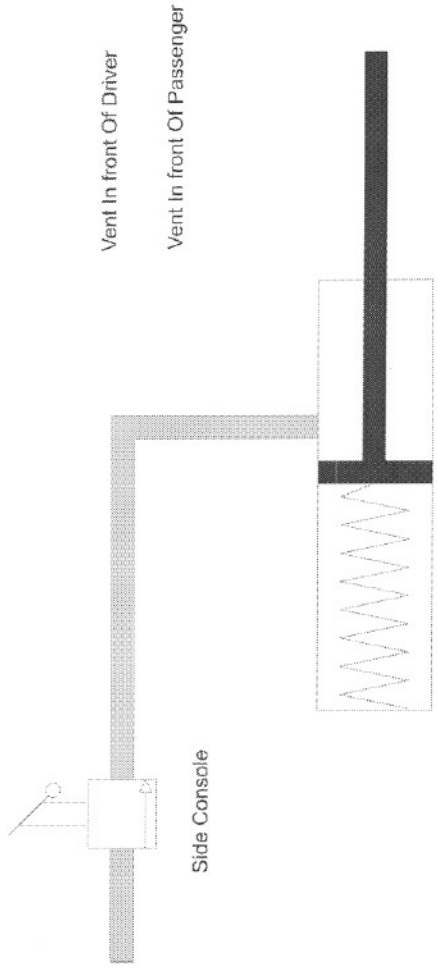

1984-021	Compressed Air Systems
Reference	Description
BBC	L. Scott W. Schreurs
DESIGN	DRAWN
	CHECKED

Air Vents

BLUESBIRD WANDERLodge CO.
 FORT VALLEY DESIGN DIV.
 1984 F.C. 35 SB

DWG NO 1984-034

Date	Revision	Description

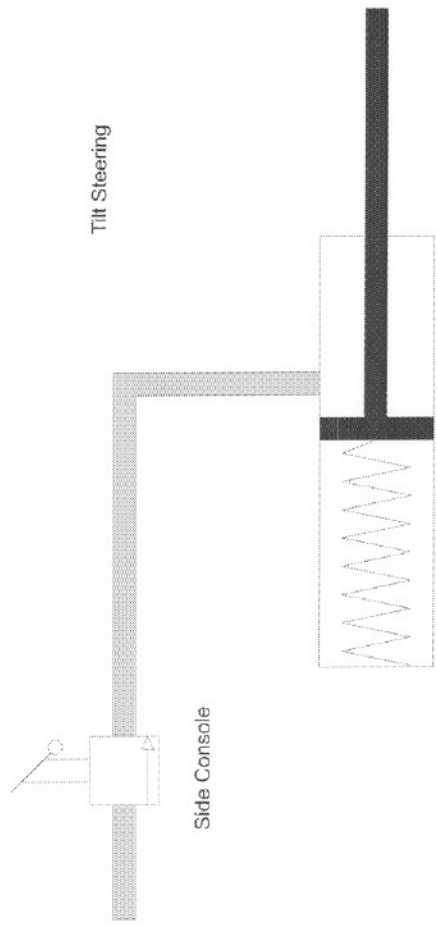

Reference	1984-021	Compressed Air Systems
DESIGN	BBC	L. Scott
DRAWN		W. Scheuvs
CHECKED		

Tilt Steering

BLUEBIRD WANDERLodge CO.
FORT VALLEY GEORGIA U.S.A.
1984 F.C. 35 SB

DWG NO 1984-035

Date	Revision	Description

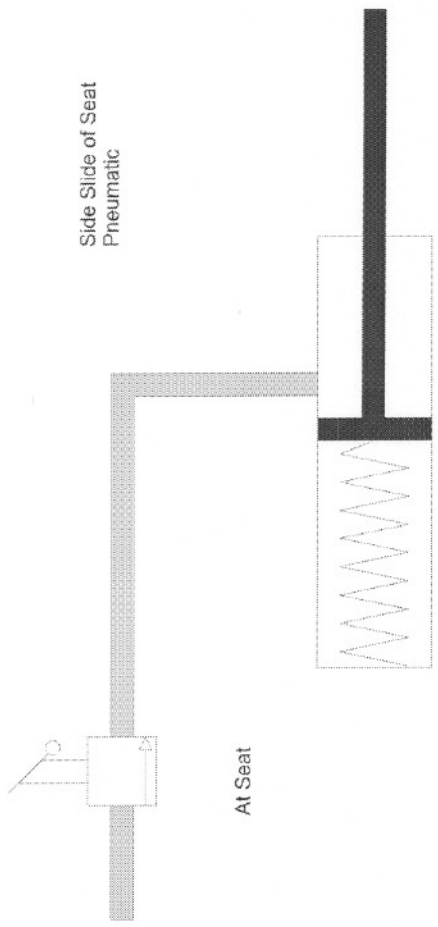

1984-021	Compressor Air System
Reference	Description
BBC	L. Scott
DESIGN	W. Schnell
	DRAWN
	CHECKED

**Front Seats
Driver & Passenger**

BLUESIRD WANDERLIDGE CO.
FORT VALLEY, GEORGIA, U.S.A.
1984 FC 95 SB

DWG NO 1984-036

Date	Revision	Description

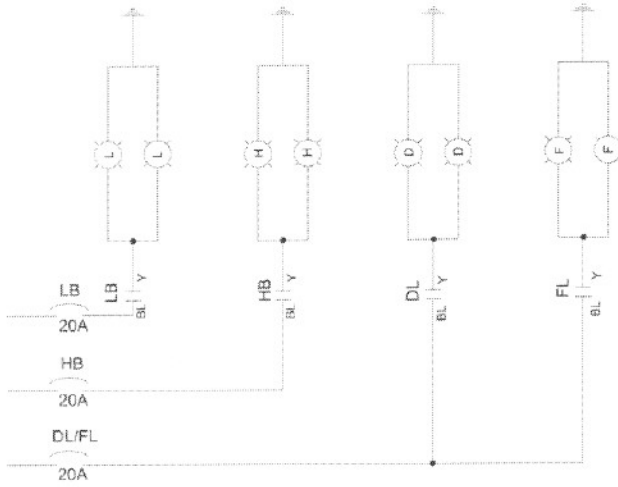

RELAYS TO BE INSTALLED

Reference	Description
BBC	L. Scott
DESIGN	W. Schreijffs
DRAWN	CHECKED

Headlight Wiring
Page 1 of 2

BLUESIRD WANDERLODGE CO.
P.O. BOX 100
1984 F.C. 35 SE

DWG NO 1984-037

Date	Revision	Description

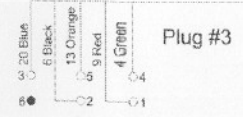
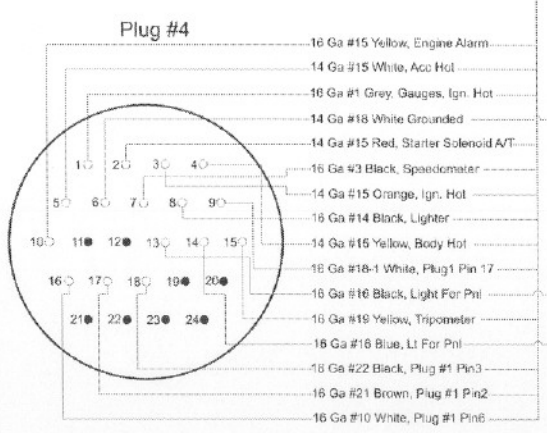
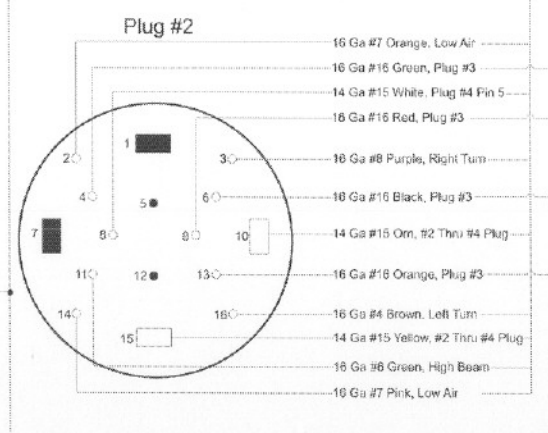
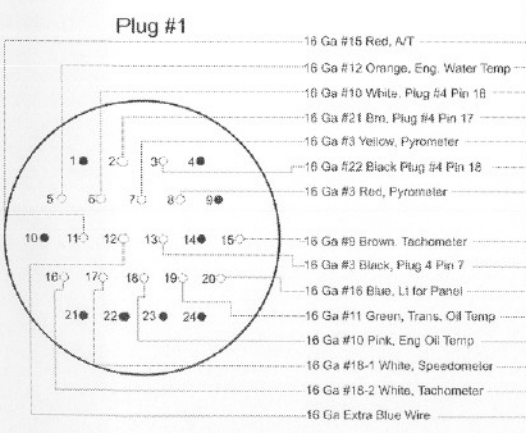
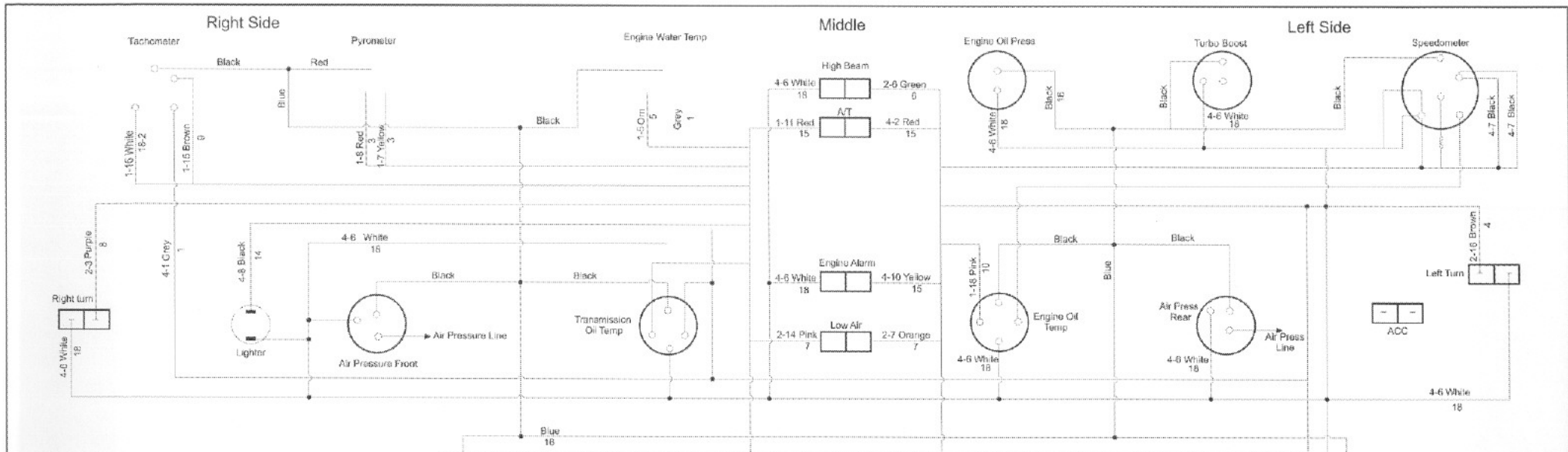

Upper Dash Reverse View

Date	Revision	Description

Reference	Description
BBC	L. Scott W. Schreurs
DESIGN	DRAWN CHECKED

Harness Upper Dash
WLFC 84 & 85
3814415

BLUEBIRD WANDERLODGE CO.
 FORT VALLEY GEORGIA U.S.A.
 1984 F.C.35 SB

DWG NO **1984 - 040**

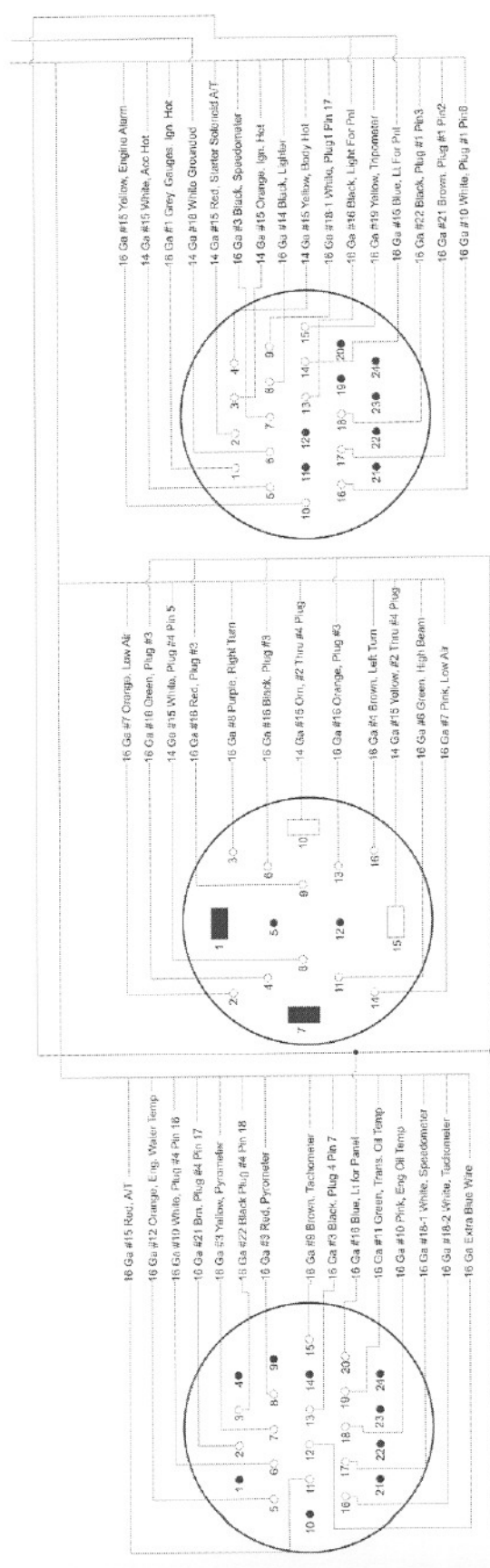

- 16 Ga #15 Yellow, Engine Alarm
- 14 Ga #15 White, Acc Hot
- 16 Ga #1 Grey Gauges Ign Hot
- 14 Ga #18 White Ground
- 14 Ga #15 Red, Starter Solenoid AT
- 16 Ga #3 Black, Speedometer
- 14 Ga #15 Orange, Ign. Hot
- 16 Ga #14 Black, Lighter
- 14 Ga #15 Yellow, Bory Hot
- 16 Ga #18-1 White, Plug 1 Pin 17
- 16 Ga #16 Black, Light For Pin
- 16 Ga #19 Yellow, Tachometer
- 16 Ga #22 Black, Plug #7 Pin 3
- 16 Ga #21 Brown, Plug #1 Pin 2
- 16 Ga #10 White, Plug #1 Pin 8

- 16 Ga #7 Orange, Low Alt
- 16 Ga #16 Green, Plug #3
- 14 Ga #15 White, Plug #4 Pin 5
- 16 Ga #18 Red, Plug #2
- 16 Ga #6 Purple, Right Turn
- 16 Ga #16 Black, Plug #3
- 14 Ga #15 Orange, #2 Turn #4 Plug
- 16 Ga #16 Orange, Plug #3
- 16 Ga #4 Brown, Left Turn
- 14 Ga #15 Yellow, #2 Turn #4 Plug
- 16 Ga #6 Green, High Beam
- 16 Ga #7 Pink, Low Alt

- 16 Ga #15 Red, AT
- 16 Ga #12 Orange, Eng. Water Temp
- 16 Ga #10 White, Plug #4 Pin 16
- 10 Ga #21 Brn, Plug #4 Pin 17
- 16 Ga #23 Yellow, Pyrometer
- 16 Ga #22 Black Plug #4 Pin 18
- 10 Ga #3 Red, Pyrometer
- 16 Ga #8 Brown, Tachometer
- 16 Ga #3 Black, Plug #4 Pin 7
- 16 Ga #10 Blue, Lt for Panel
- 16 Ga #11 Green, Trans. Oil Temp
- 16 Ga #10 Pink, Eng Oil Temp
- 16 Ga #18-1 White, Speedometer
- 16 Ga #18-2 White, Tachometer
- 16 Ga Extra Blue Wire

Reference	Description
BBC	L. Scott W. Schneurs
DESIGN	DRAWN
	CHECKED

Wiring Harness Dash

BLUESIRD WANDERLOGGE CO.
PORT VALLEY, OREGON U.S.A.
1984 F.C.35 SB

DWG NO 1984 - 041

Date	Revision	Description

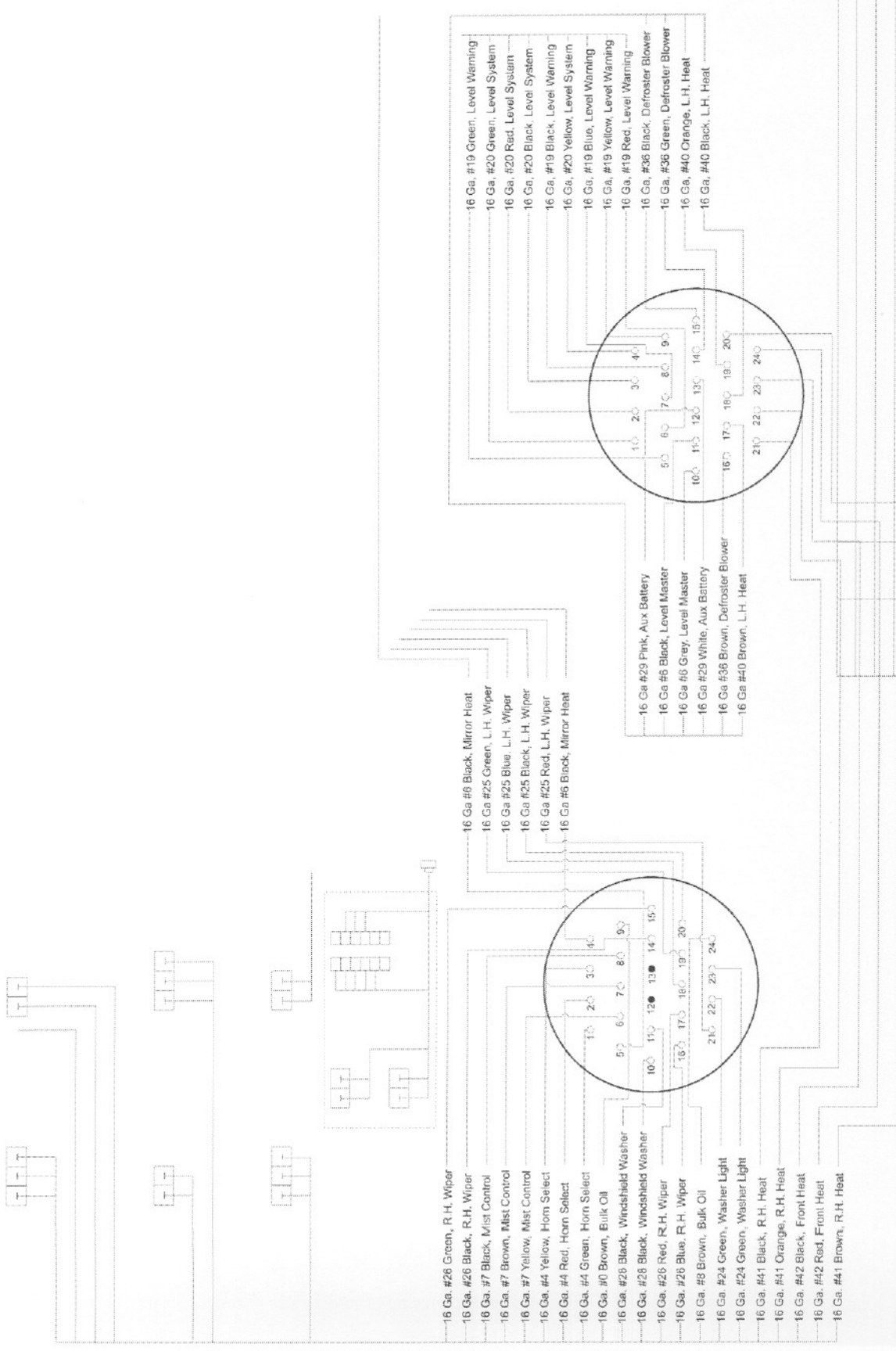

- 16 Ga. #26 Green, R.H. Wiper
- 16 Ga. #28 Black, R.H. Wiper
- 16 Ga. #7 Black, Mist Control
- 16 Ga. #7 Brown, Mist Control
- 16 Ga. #7 Yellow, Mist Control
- 16 Ga. #4 Yellow, Horn Select
- 16 Ga. #4 Red, Horn Select
- 16 Ga. #4 Green, Horn Select
- 16 Ga. #0 Brown, Bulk Oil
- 16 Ga. #28 Black, Windshield Washer
- 16 Ga. #28 Black, Windshield Washer
- 16 Ga. #26 Red, R.H. Wiper
- 16 Ga. #28 Blue, R.H. Wiper
- 16 Ga. #8 Brown, Bulk Oil
- 16 Ga. #24 Green, Washer Light
- 16 Ga. #24 Green, Washer Light
- 16 Ga. #41 Black, R.H. Heat
- 16 Ga. #41 Orange, R.H. Heat
- 16 Ga. #42 Black, Front Heat
- 16 Ga. #42 Red, Front Heat
- 16 Ga. #41 Brown, R.H. Heat
- 16 Ga. #6 Black, Mirror Heat
- 16 Ga. #25 Green, L.H. Wiper
- 16 Ga. #25 Blue, L.H. Wiper
- 16 Ga. #25 Black, L.H. Wiper
- 16 Ga. #25 Red, L.H. Wiper
- 16 Ga. #6 Black, Mirror Heat
- 16 Ga. #29 Pink, Aux Battery
- 16 Ga. #6 Black, Level Master
- 16 Ga. #6 Grey, Level Master
- 16 Ga. #29 White, Aux Battery
- 16 Ga. #38 Brown, Defroster Blower
- 16 Ga. #40 Brown, L.H. Heat
- 16 Ga. #19 Green, Level Warning
- 16 Ga. #20 Green, Level System
- 16 Ga. #20 Red, Level System
- 16 Ga. #20 Black, Level System
- 16 Ga. #19 Black, Level Warning
- 16 Ga. #20 Yellow, Level System
- 16 Ga. #19 Blue, Level Warning
- 16 Ga. #19 Yellow, Level Warning
- 16 Ga. #19 Red, Level Warning
- 16 Ga. #36 Black, Defroster Blower
- 16 Ga. #36 Green, Defroster Blower
- 16 Ga. #40 Orange, L.H. Heat
- 16 Ga. #40 Black, L.H. Heat

Reference	Description
BBC	L. Scott
DESIGN	W. Schreurs
	DRAWN
	CHECKED

Harness, Lower Dash
WLFC, 84 & 85
3814407

BLUEBIRD WANDERLORDE CO.
 FORT VALLEY, MISSISSIPPI 38927
 1984 F.C. 35 5B

DWG NO **1984-042**

Date	Revision	Description

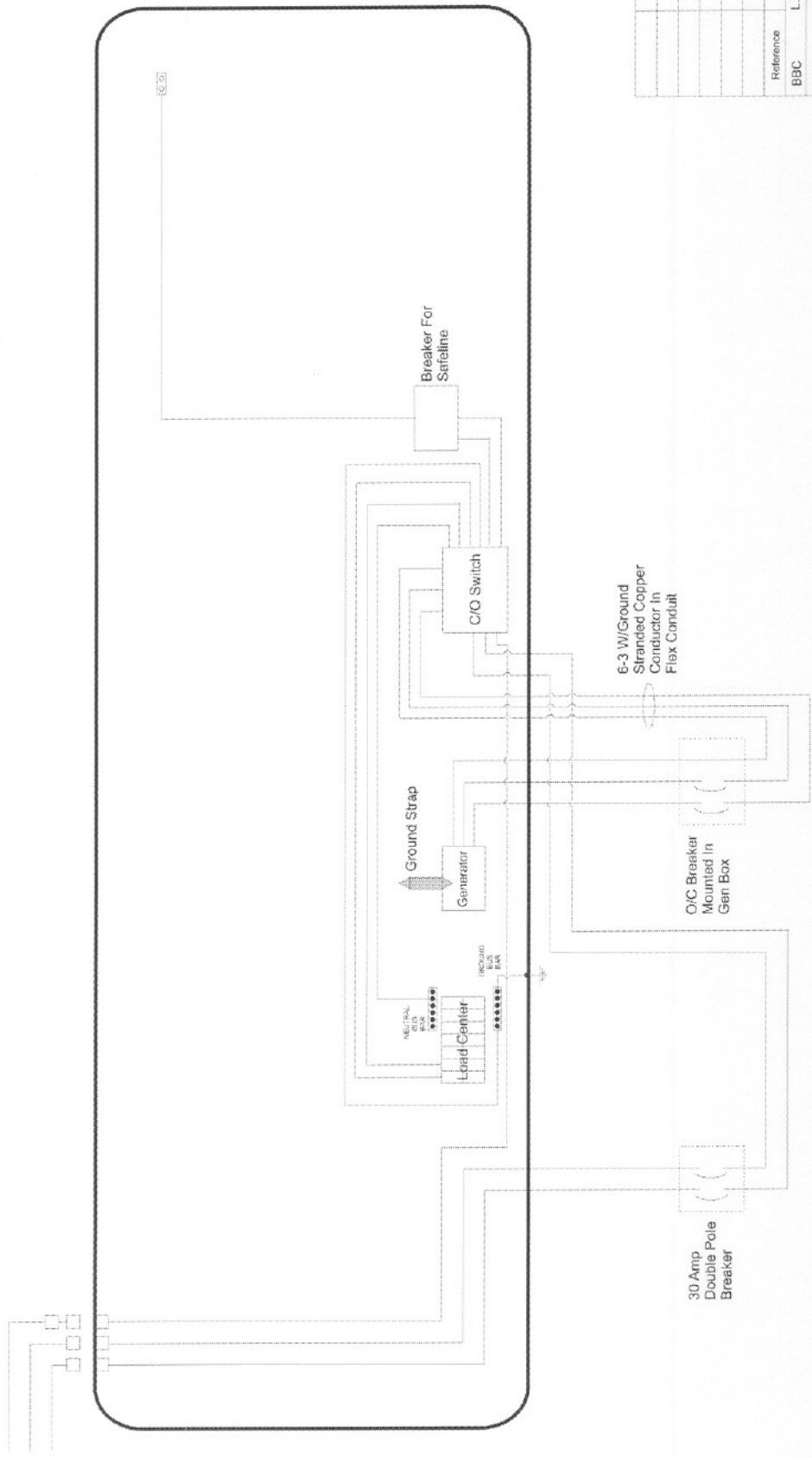

Main AC Wiring

Reference	Description
BBC	L. Scott W. Schreurs
DESIGN	DRAWN CHECKED

BLUEBIRD WANDERLodge CO
 FORT VALLEY, IOWA U.S.A.
 1984 F.C.35 SB

DWG NO 1984-043

Date	Revision	Description

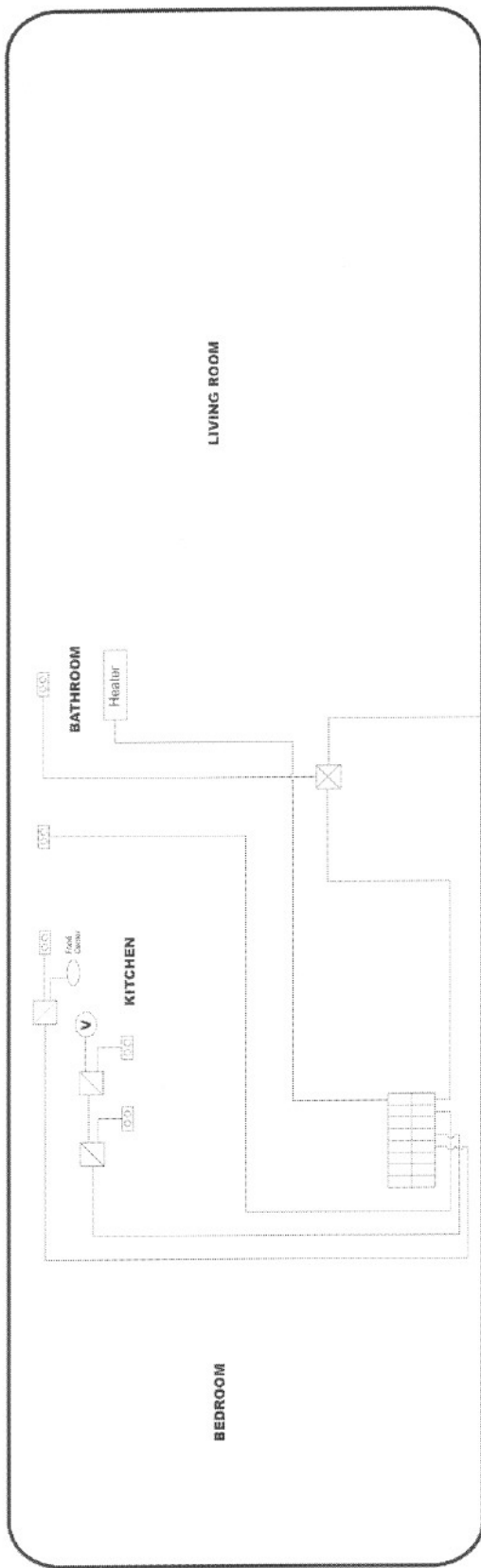

Reference	Description
BBC	L. Scott W. Schreurs
DESIGN	DRAWN
	CHECKED

AC Wiring
Kitchen / Bathroom

BLUEBIRD WANDERLODGE CO.
FORT VALLEY, GEORGIA U.S.A.
1984 F.C. 35 SB

DWG NO 1984-044

Date	Revision	Description

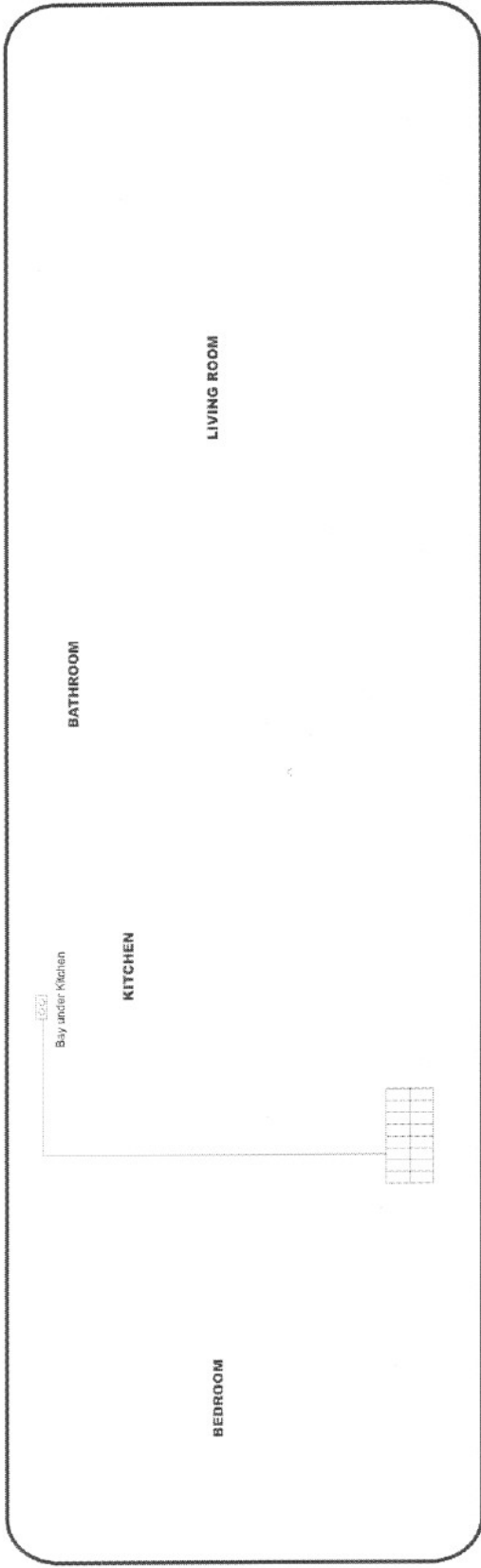

Reference	Description
BBC	L. Scott W. Schreurs
DESIGN	DRAWN
	CHECKED

AC Wiring Bay

BLUEBIRD WANDERLODGE CO.
 FORT VALLEY, GEORGIA U.S.A.
 1984 F.C. 95 SB

Date	Revision	Description

DWG NO 1984-045

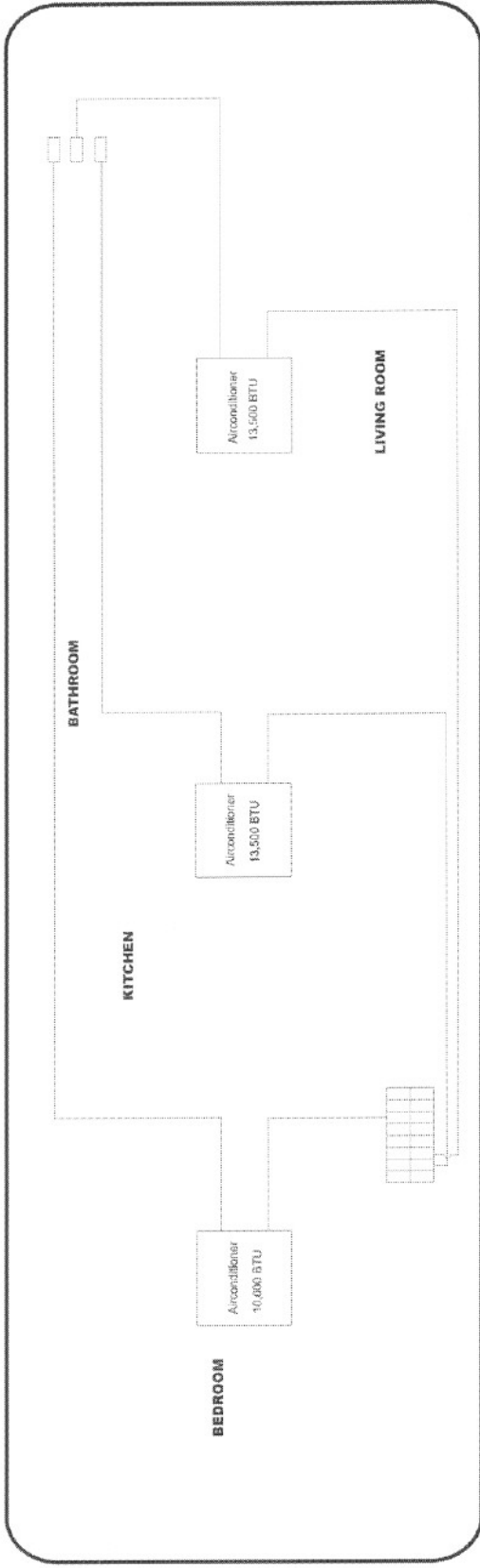

Reference	Description
BBC	L. Scott W. Schreiff
DESIGN	DRAWN
	CHECKED

**AC Wiring
Air Conditioners**

BLUESBIRD WANDERLODGE CO.
EIGHT VALLEY GEORGIA U.S.A.
1984 F.C. 35 SB

DWG NO 1984-046

Date	Revision	Description

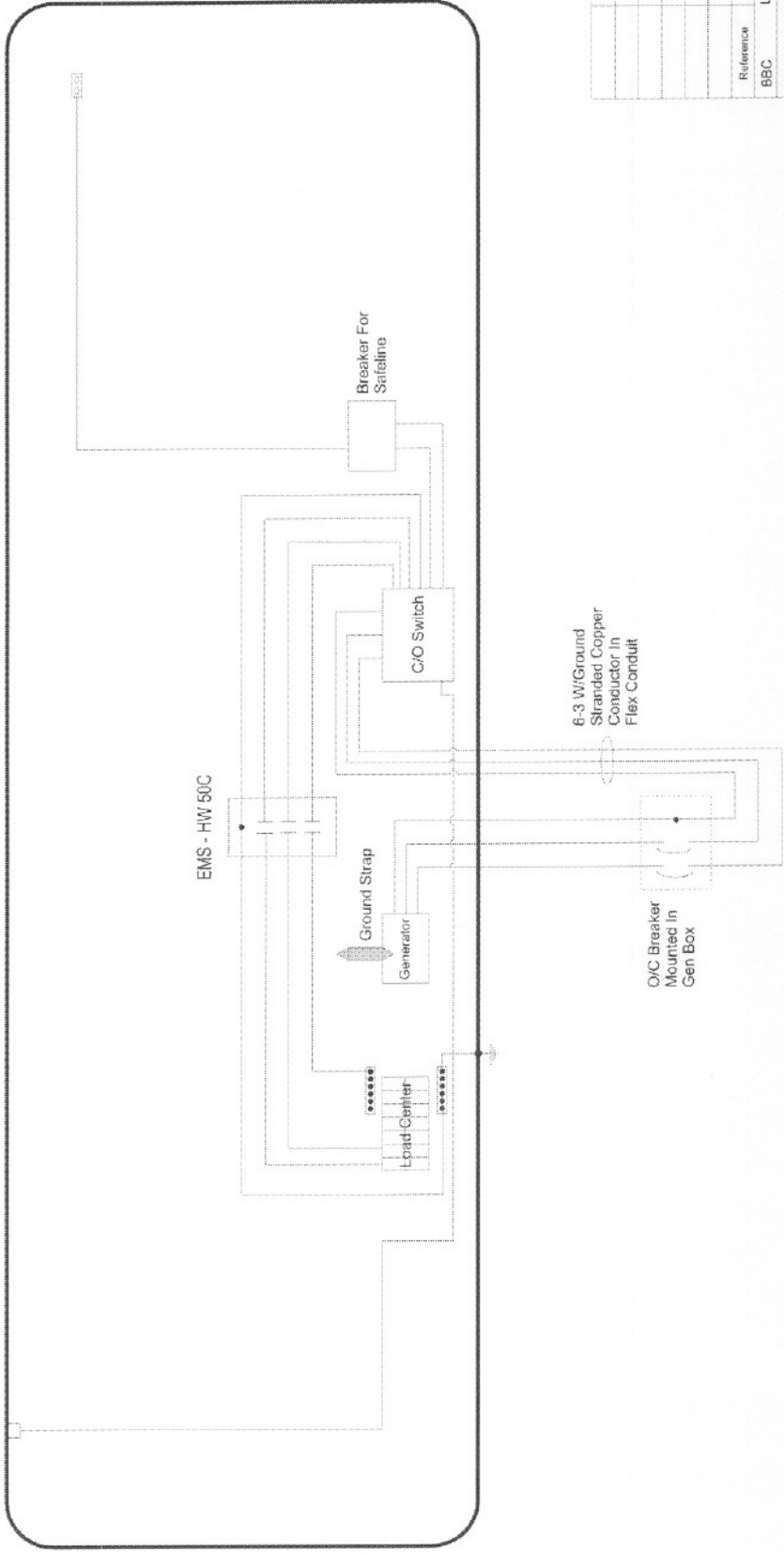

Reference	Description
BBC	L. Scott
DESIGN	W. Schreus
	DRAWN
	CHECKED

Main AC Wiring Modified

BLUESIRD WANDERLODGE CO.
 1001 W. 10th Street, Suite 101
 Fort Worth, Texas 76102, U.S.A.
 1984 F.C. 38 SB

DWG NO **1984-047**

Date	Revision	Description

AC LOAD CENTER

Bryant Model No 12-24 FMG (Part No. 2207918)

	20A Leg 1	MAIN	50A Leg 1
Center A / C	20A Leg 2	MAIN	50A Leg 2
Front A / C	20A Leg 1	Battery Charger	20A Leg 1
Kitchen Receptacle	20A Leg 2	Hot Water Heater	20A Leg 2
Refridgerator Receptacle	20A Leg 1	Rear Receptacle	20A Leg 1
Front Receptacle	20A Leg 2	Rear A / C	20A Leg 2
Microwave Receptacle	20A Leg 1		20A Leg 1
Bathroom & Outside Receptacle	20A GFCI Leg 2	Bathroom Heater	20A Leg 2



Ground Bar
to Metal Body Frame



Insulated
Neutral Bar

GFCI is a Bryant Model GFCB 120

Reference	Description	
BBC	L. Scott	W. Schreurs
DESIGN	DRAWN	CHECKED

AC WIRING PANEL

BLUEBIRD WANDERLODGE CO.
FORT VALLEY GEORGIA U.S.A.
1984 F.C. 35 SB

DWG NO 1984 - 048

Date	Revision	Description

AC CHANGE-OVER SWITCH

Model # Kraus & Naimer C-105 B281E UL Listed 100 Amp

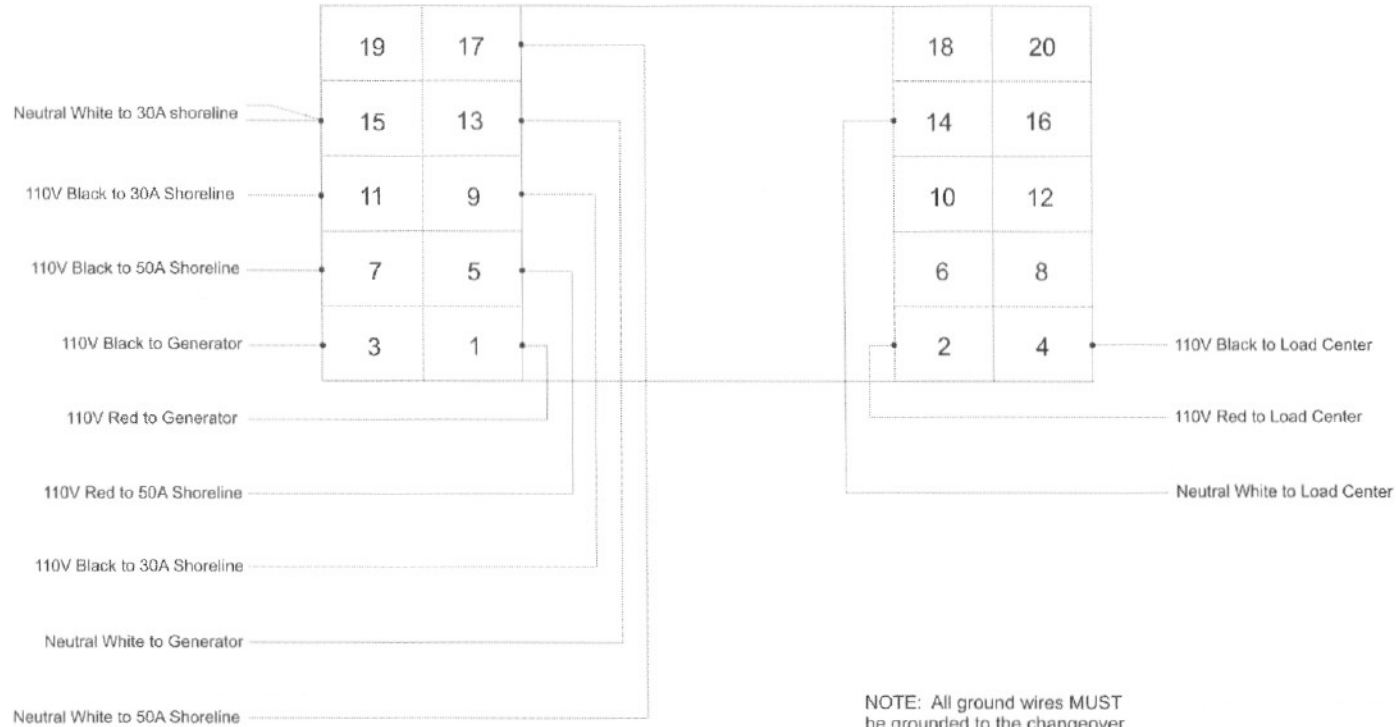

NOTE: All ground wires MUST be grounded to the changeover switch enclosure, outlet box or junction box.

Reference	Description	
BBC	L. Scott	W. Schreurs
DESIGN	DRAWN	CHECKED
AC CHANGE-OVER SWITCH		
BLUEBIRD WANDERLODGE CO. FORT VALLEY GEORGIA U.S.A. 1984 F.C. 35 SB		
DWG NO	1984 -049	

Date	Revision	Description

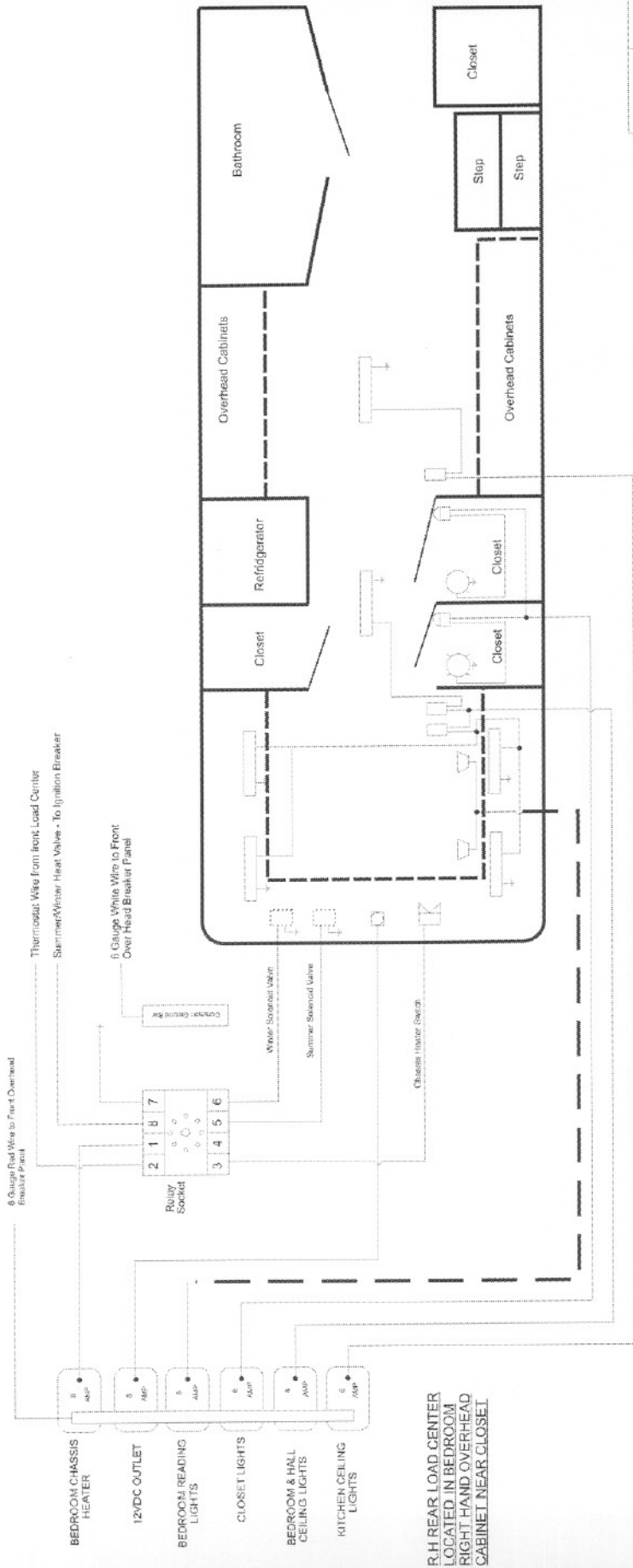

R. H REAR LOAD CENTER
 LOCATED IN BEDROOM
 RIGHT HAND OVERHEAD
 CABINET NEAR CLOSET

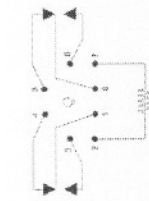

ELECTRICAL DIAGRAM OF RELAY

- NOTES:
1. ALL GROUND WIRES ARE RUN BACK TO COMMON GROUND BAR LOCATED ON RIGHT HAND LOAD CENTER
 2. WINTER AND SUMMER SOLENOIDS ARE CHASSIS GROUNDED
 3. WIRE SIZE FOR 8 AMP BREAKER IS 18 GAUGE WIRE OR LARGER
 4. WIRE SIZE FOR 15 AMP BREAKER IS 16 GAUGE WIRE OR LARGER
 5. GROUND WIRES TO BE SAME GAUGE WIRE AS ON BREAKER OR LARGER
 6. ALL LOW VOLTAGE WIRING IS SAE J578 TYPE SXL
 7. ALL 12 VOLT CIRCUIT BREAKERS OR FUSES SHALL BE OF THE APPROVED TYPE (SAE J558, ANSI C118.1) AND UL INC.
 8. ALL WIRE STRANDED COPPER

Reference	Description
BBC	L. Scott
DESIGN	DESIGN
CHECKED	CHECKED

**12 Volt DC Load Center
 Rear Right Hand**

BLUEBIRD WANDERLODGE CO.
 FORT VALLEY, GEORGIA U.S.A.
 1984 F.C. 35 SB

DWG NO 1984 - 050

Date	Revision	Description

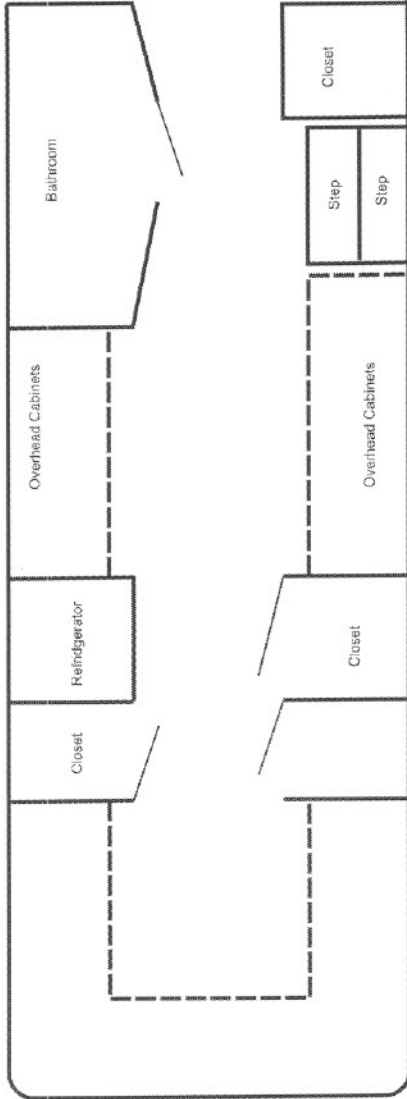
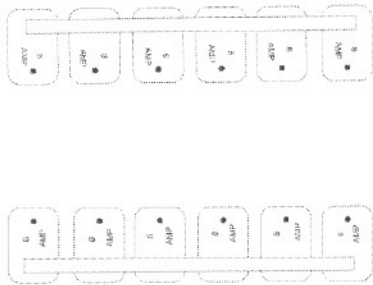

NOTES:

1. ALL GROUND WIRES ARE RUN BACK TO COMMON GROUND BAR LOCATED ON RIGHT HAND LOAD CENTER
2. WINTER AND SUMMER SOLENOIDS ARE CHASSIS GROUNDED
3. WIRE SIZE FOR 6 AMP BREAKER IS 18 GAUGE WIRE OR LARGER
4. WIRE SIZE FOR 8 AMP BREAKER IS 16 GAUGE WIRE OR LARGER
5. GROUND WIRE IS TO BE SAME GAUGE WIRE AS ON BREAKER OR LARGER
6. ALL LOW VOLTAGE WIRING IS SAC-1878 TYPE CXL
7. ALL WIRE TYPES AND SIZES OR FUSES SHALL BE OF THE APPROVED TYPE (SAE J558; ANSI C118.1) AND UL INC.
8. ALL WIRE STRANDED COPPER

6 Gauge White Wire to Front Over-Head Breaker Panel

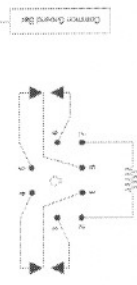

ELECTRICAL DIAGRAM OF RELAY

R.H REAR LOAD CENTER
LOCATED IN BEDROOM
RIGHT HAND OVERHEAD
CABINET NEAR CLOSET

Reference	Description
BBC	L. Scott W. Schreits
DESIGN	DRAWN
	CHECKED

12 Volt DC Load Center
Rear Right Hand

BLUEBIRD WANDERLodge CO.
FORT VALLEY, GEORGIA U.S.A.
1984 F.C. 35 SB

DWG NO 1984 - 052

Date	Revision	Description

Reference	Description
BBC	L. Scott
DESIGN	W. Schreurs
	DRAWN
	CHECKED

Kohler Schematic
Ref. 258399

BLUEBIRD WANDERLODGE CO.
 FORT VALLEY, GEORGIA, U.S.A.
 1984, F.C. 35 SB

DWG NO 1984-055

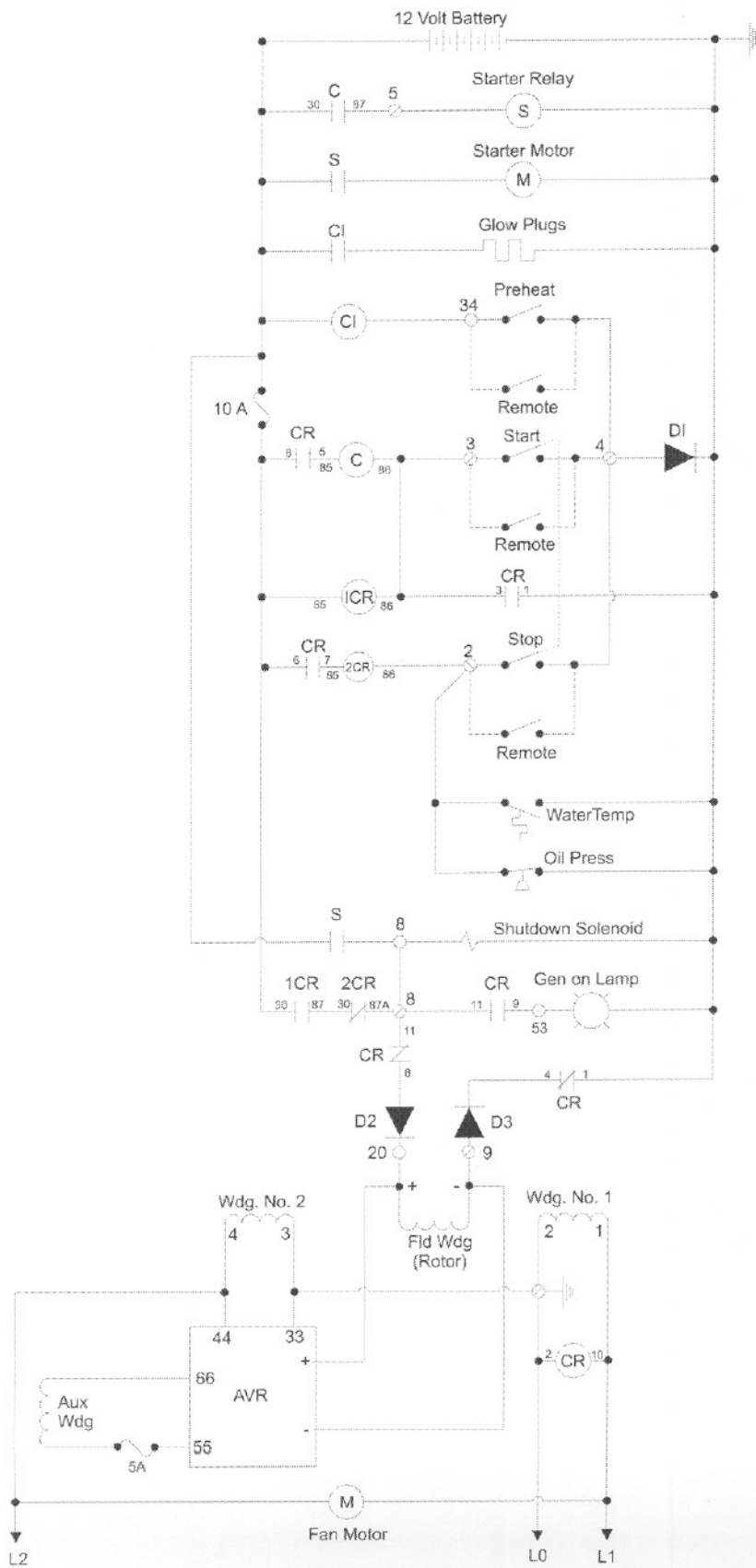

Date	Revision	Description

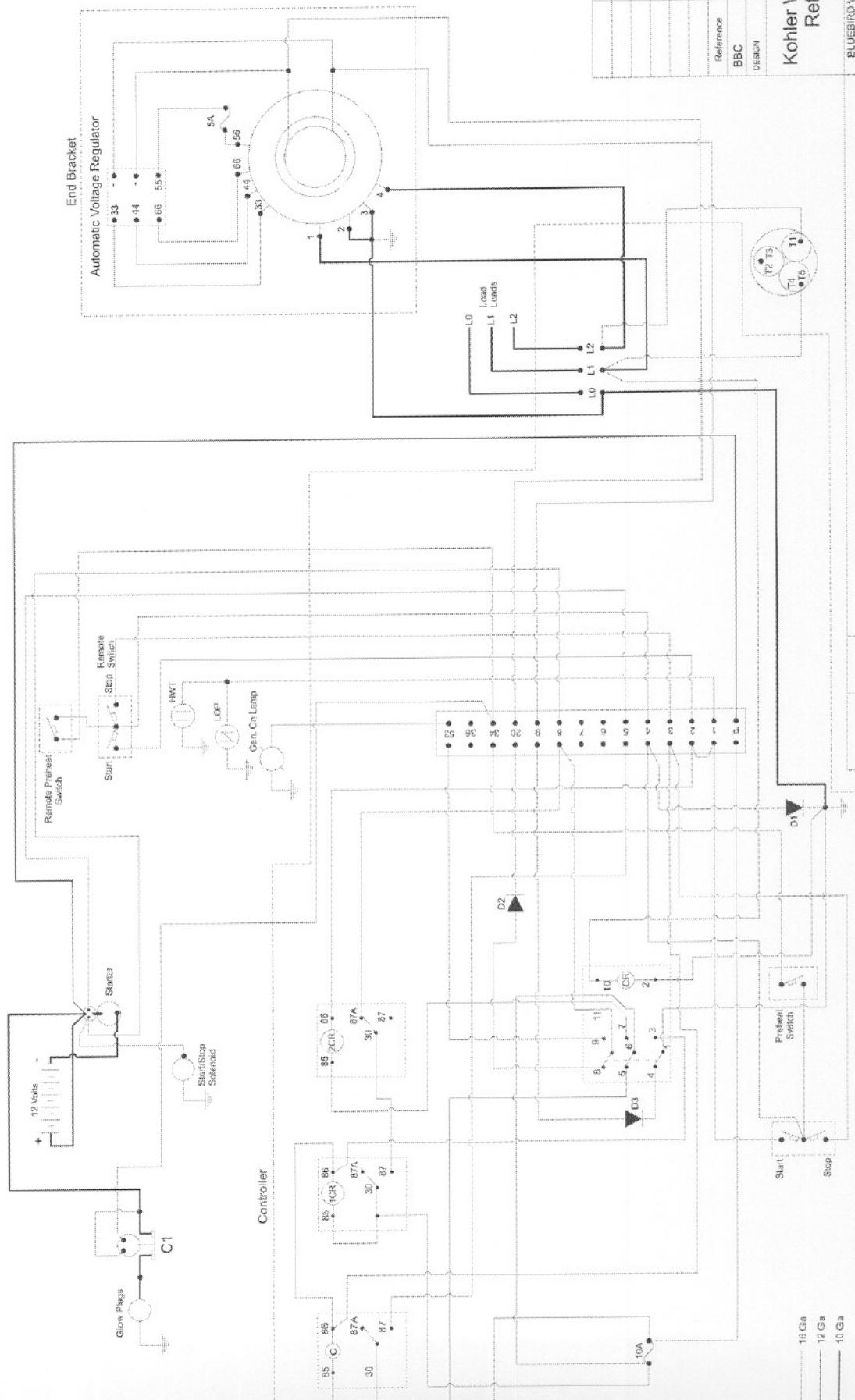

End Bracket
Automatic Voltage Regulator

Reference	Description
BBC	L. Scott W. Schneurs
DESIGN	DRAWN
	CHECKED

Kohler Wiring Diagram
Ref. 258399

BLUEBIRD WANDERLÖDGE CO.
FORT VALLEY, GEORGIA U.S.A.
1984 F.C. 35 SB

DWG NO 1984-055A

Date	Revision	Description

- 18 Ga
- 12 Ga
- 10 Ga

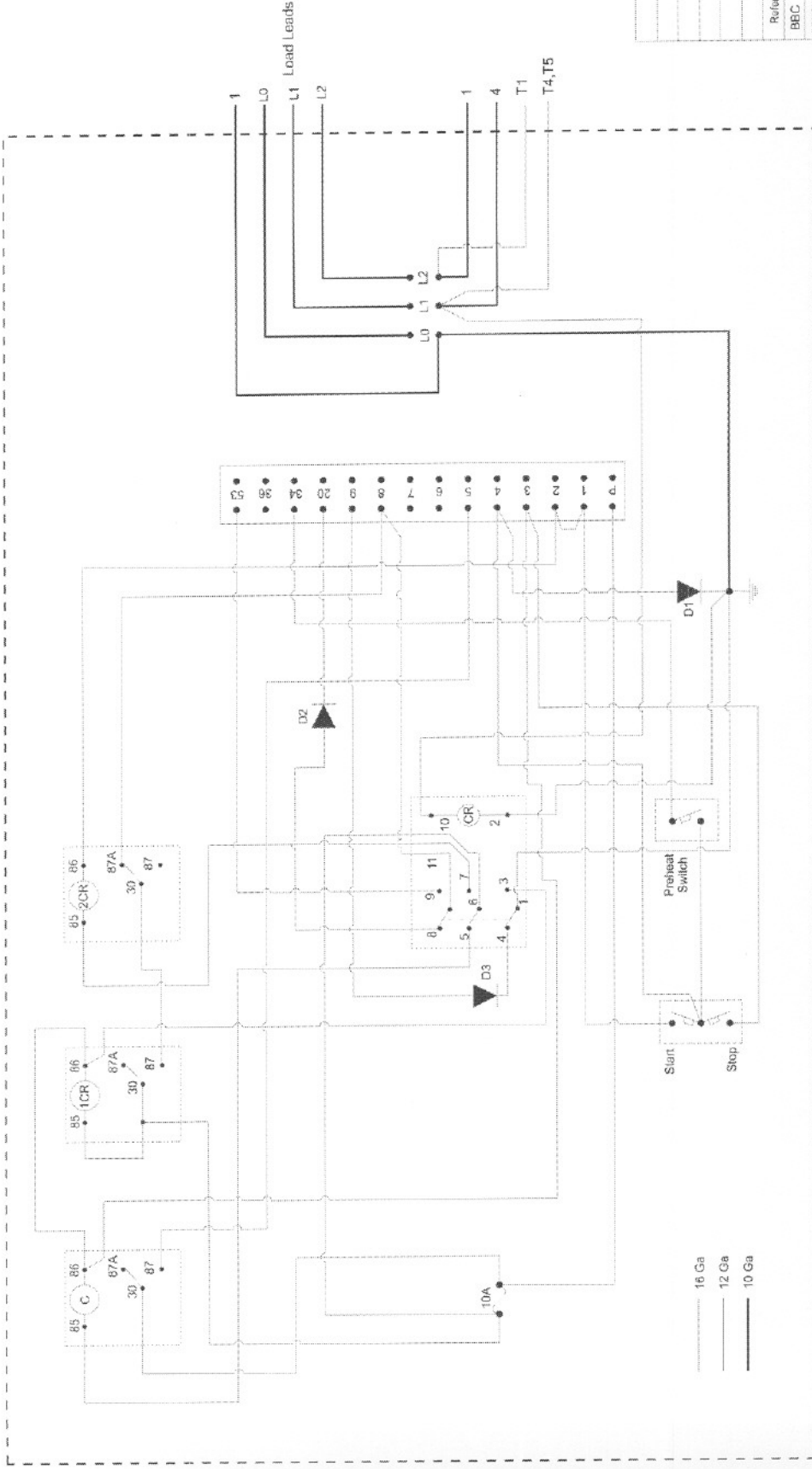

..... 16 Ga
 - - - - - 12 Ga
 10 Ga

Controller

Reference	Description
BBC	L. Scott W. Schreits
DESIGN	DRAWN
	CHECKED

Kohler Controller
Ref. 258399

BLUEBIRD WANDERLODGE CO.
 FORT VALLEY, GEORGIA U.S.A.
 1994 F.C. 35 SB

DWG NO 1984-055B

Date	Revision	Description

End Bracket

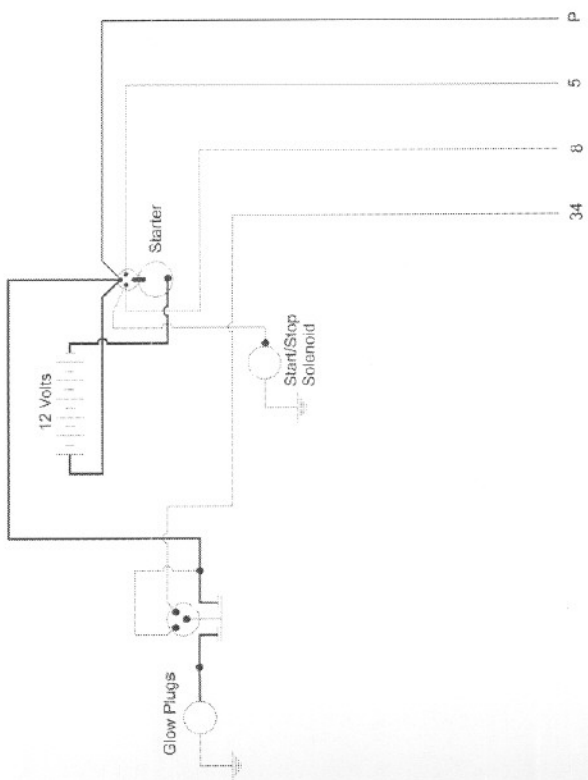
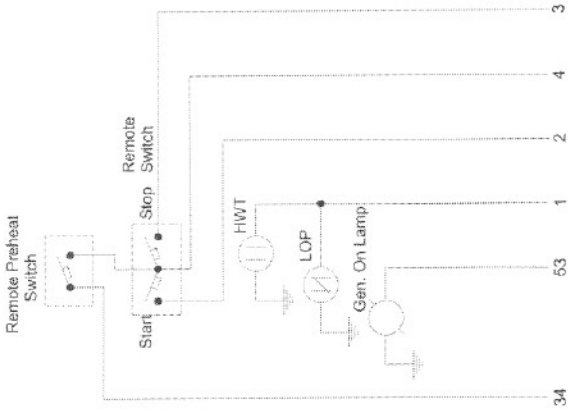
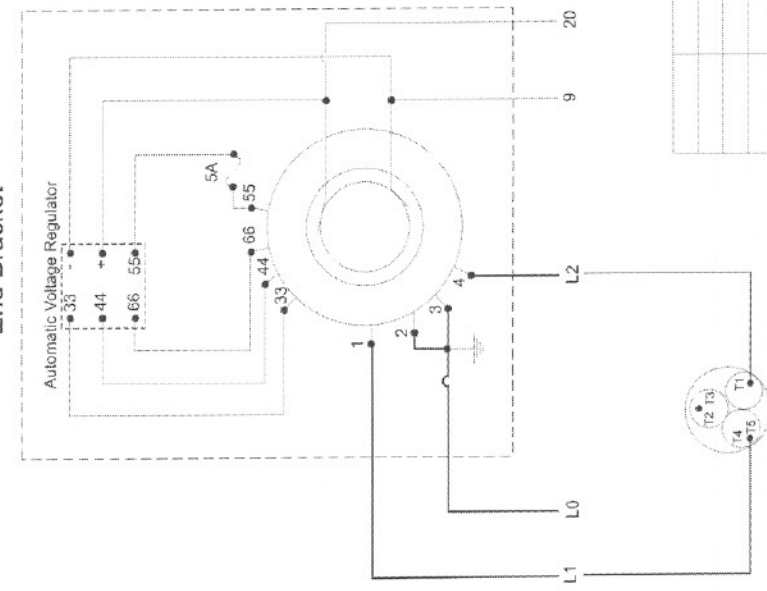

Reference	Description
BBC	L. Scott W. Schreurs
DESIGN	DRAWN
	CHECKED

Kohler External Wiring
Ref. 258399

BLUESBIRD WINDERLODGE CO.
P.O. BOX 1000
1984 F.C. 35 SE

DWG NO 1984-055C

Date	Revision	Description

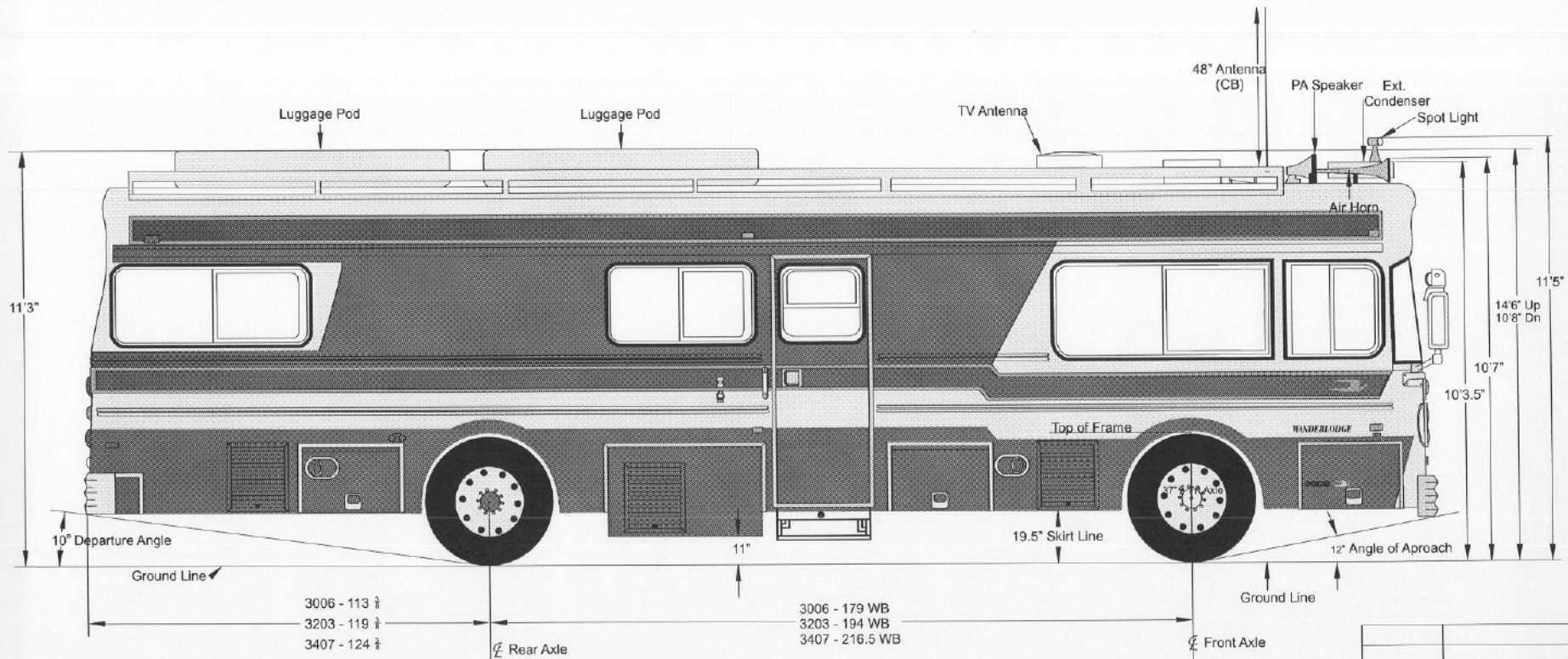

Note: All Dimensions were taken with 1100 tires.
 Add 5 inch for 1200 tires. Also, air bags
 were fully inflated. Subtract 4.25 inch when
 air bags are deflated. Unit is 8" wide, not
 including mirrors, awning, etc.

Body Model	TURNING RADIUS		
	Wheelbase	Curb Radius	Wall Radius
3006	179	29.4	33.7
3203	194	31.3	35.6
3407	216.5	34.1	38.5

Reference	Description	
BBC	L. Scott	W. Schreurs
DESIGN	DRAWN	CHECKED
Elevation, Standard height Dimensions BB DWG 3810785		
BLUEBIRD WANDERLODGE CO. FORT WALLEY GEORGIA U.S.A. 1984 F.C. 35 SB		
DWG NO	1984-070	

Date	Revision	Description